

DESIGN AND ANALYSIS OF FLYWHEEL IN PETROL ENGINE

Design and stress analysis

¹A.Selvakumar, ²S.Rajapandi, ³B.Santhoshkumar, ⁴R.Vaitheeswaran

¹Assistant Professor

¹Department of Mechanical Engineering,

¹Prathyusha Engineering College, Thiruvallur, India

Abstract: A flywheel is an energy storage device. It is used in machines serves as a reservoir which stores energy during the period when the supply of energy is more than the requirement and releases it during the period when the requirement of energy is more than supply. The modelling of flywheel is created in CATIA tool and is imported to ANSYS for analysis. Finite Element Analysis is used to calculate the stresses inside the flywheel. The analysis on various geometric forms of Flywheel such as solid type, rim type, web type & spoke type of flywheel has been carried out and appropriate results have been extracted & moreover analysis has been carried out on the specific rotation of flywheel. For example, in I.C. engines, the energy is developed only in the power stroke which is much more than engine load, and no energy is being developed during the suction, compression and exhaust strokes in case of four stroke engines. The excess energy is developed during power stroke is absorbed by the flywheel and releases it to the crank shaft during the other strokes in which no energy is developed, thus rotating the crankshaft at a uniform speed.

Index Terms - Flywheel, Stress, ANSYS, Deformation, Energy.

I. INTRODUCTION

A flywheel is a mechanical device with a significant moment of inertia used as a storage device for rotational energy. Flywheels resist changes in their rotational speed, which helps steady the rotation of the shaft when a fluctuating torque is exerted on it by its power source such as a piston-based (reciprocating) engine, or when an intermittent load, such as a piston pump, is placed on it. Flywheels are typically made of steel and rotate on conventional bearings; these are generally limited to a revolution rate of a few thousand RPM. Some modern flywheels are made of carbon fiber materials and employ magnetic bearings, enabling them to revolve at speeds up to 60,000 RPM. Carbon-composite flywheel batteries have recently been manufactured and are proving to be viable in real-world tests on mainstream cars. Our aim is to increase the amount of rotational energy stored in the flywheel during the working cycle by using different materials. This will help in the improvement of efficiency of the engine and makes the vehicle movement faster.

A. ORIGINS

The next big milestones occurred during the early 1970s when flywheel energy storage was proposed as a primary objective for electric vehicles and stationary power back-up. In the years immediately following, fiber composite rotors were built and tested in the laboratory by US Flywheel Systems and other organizations. However, it was not until the 1980s when relatively low speed magnetic bearings and motor-generators made their advanced appearance.

Projections of flywheel energy storage technology into the 21st Century shall advance by more inexpensive and stronger fiber materials and resin systems. Increases in tensile modulus also improve system performance with stiffer rotors and housing structures. This is significant, since energy density is proportional to tensile strength. The cost and performance of magnetic bearing technology is advancing flywheel system with lower operational power, higher load capacity, and faster response.

B. COMPARISON AMONG ALTERNATIVE FORMS OF ENERGY STORAGE

Chemical batteries are widely used in many applications currently. But there are a number of drawbacks of chemical batteries.

1. Narrow operational temperature range. The performance of the chemical battery will be deteriorated sharply at high or low temperature.
2. Capacity decreases over life. The capacity of the chemical battery cannot be maintained in a high level all through its life, the capacity will decrease with time goes on.
3. Difficulty in obtaining charge status. It is not so easy to know the degree of the charge of the chemical battery because the chemical reaction in the battery is very hard to measure and control.
4. Overcharge and over-discharge. Chemical battery can neither be over-discharged nor be over-charged, or its life will be shorted sharply.
5. Environmental concerns. Many elements of the chemical battery are poisonous, they will do harm to the environment and the people.

Obviously, the presence of the shortcomings of the chemical batteries makes them not so appealing to the users nowadays. Instead, flywheel energy storage system becomes potential alternative form of energy storage.

Table I shows the comparison among chemical battery and flywheel energy storage system. Given the state of development of flywheel batteries, it is expected that costs for flywheel can be lowered with further technical development. On the other hand, electro chemical batteries already have a tremendous economy of scale that has driven costs down as far as they are likely to go.

C.MATERIAL USED FOR FLYWHEEL:

1. Aluminum
2. Beryllium
3. Carbon steel

II. SOFTWARE

The software will start (by default) with all toolbars docked to the edges of the main window. The toolbars contain buttons, which when clicked, open the various information windows or operate features in the software. The toolbars and windows can be freely moved around inside the main program window, to create your own screen layout.

A.INRODUCTION TO CATIA

CATIA started as an in-house development in 1977 by French aircraft manufacturer Avion Marcel Dassault, at that time customer of the CADAM software to develop Dassault's Mirage fighter jet. It was later adopted by the aerospace, automotive, shipbuilding, and other industries. Commonly referred to as a software suite, CATIA supports multiple stages of product development (CAx), including conceptualization, design (CAD), engineering (CAE) and manufacturing (CAM). CATIA facilitates collaborative engineering across disciplines around its 3DEXPERIENCE platform, including surfacing & shape design, electrical, fluid and electronic systems design, mechanical engineering and systems engineering. CATIA facilitates the design of electronic, electrical, and distributed systems such as fluid and HVAC systems, all the way to the production of documentation for manufacturing.

B. INTRODUCTION TO ANSYS WORKBENCH

ANSYS can carry out advanced engineering analyses quickly, safely and practically by its variety of contact algorithms, time based loading features and nonlinear material models. ANSYS Workbench is a platform which integrate simulation technologies and parametric CAD systems with unique automation and performance. The power of ANSYS Workbench comes from ANSYS solver algorithms with years of experience. Furthermore, the object of ANSYS Workbench is verification and improving of the product in virtual environment. ANSYS Workbench, which is written for high level compatibility with especially PC, is more than an interface and anybody who has an ANSYS license can work with ANSYS Workbench. As same as ANSYS interface, capacities of ANSYS Workbench are limited due to possessed license. In the planetary dual mass flywheel, the planetary gear and the torsional damper are incorporated into the flywheel. For this purpose, the flywheel is divided into a primary and a secondary mass, hence the name exists planetary "dual mass flywheel". Rattle and booming noise are now a thing of the past which is rectified by DMF. Again By reducing the mass and keeping the Inertia factor same we will be able to optimize the Dual mass flywheel giving the better results than that of conventional flywheel. ANSYS mechanical is a finite element analysis tool for structural analysis including linear, non linear and dynamic studies. This computer simulation product provides finite elements to model behavior and supports material models and equation solvers for a wide range of mechanical design problems. ANSYS mechanical also includes thermal HYPER LINK and coupled analysis capabilities acoustics, piezoelectric, thermal –structural and thermo electric analysis.

III.DESIGN

DESIGN CALCULATION:

Let,

- R=radius of flywheel
- b=breath of flywheel
- ρ =density of material
- ω =angular speed

FORMULA USED:

i) $I = \pi R^2 b \rho / (2)$

ii) $m = \pi R^2 b \rho$

Now substituting the values,

1. CARBON STEEL:

a) GENERAL:

i) $I = \pi R^2 b \rho / (2)$

$$= [\pi * (0.54)^2 * (0.062) * 7800] / (2)$$
$$= 221.5 \text{ kg-m}^2$$

ii) $m = \pi R^2 b \rho$

$$= \pi * (0.54)^2 * (0.062) * 7800$$
$$= 444.3 \text{ kg}$$

3. BERYLLIUM:

a) GENERAL:

i) $I = \pi R^2 b \rho / (2)$

$$= [\pi * (0.54)^2 * (0.062) * 1850] / (2)$$
$$= 52.75 \text{ kg-m}^2$$

ii) $m = \pi R^2 b \rho$

$$= \pi * (0.54)^2 * (0.062) * 1850$$
$$= 105.48 \text{ kg}$$

4. ALUMINUM:

a) GENERAL:

$$i) I = \pi R^2 b \rho / (2)$$

$$= [\pi * (0.54)^2 * (0.062) * 2700] / (2)$$

$$= 76.97 \text{ kg-m}^2$$

$$ii) m = \pi R^2 b \rho$$

$$= \pi * (0.54)^2 * (0.062) * 2700$$

$$= 153.35 \text{ kg}$$

SOLID TYPE FLYWHEEL:

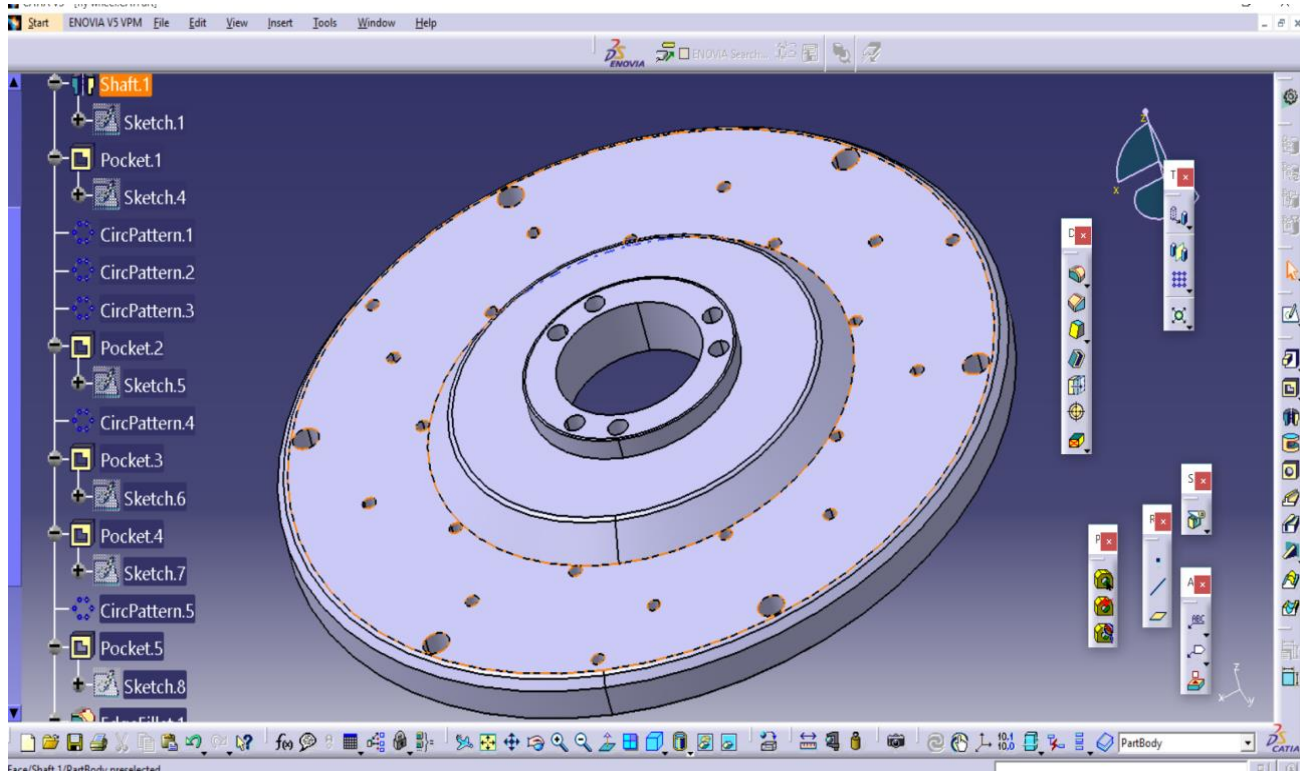

DIFFERENT VIEWS OF FLYWHEEL

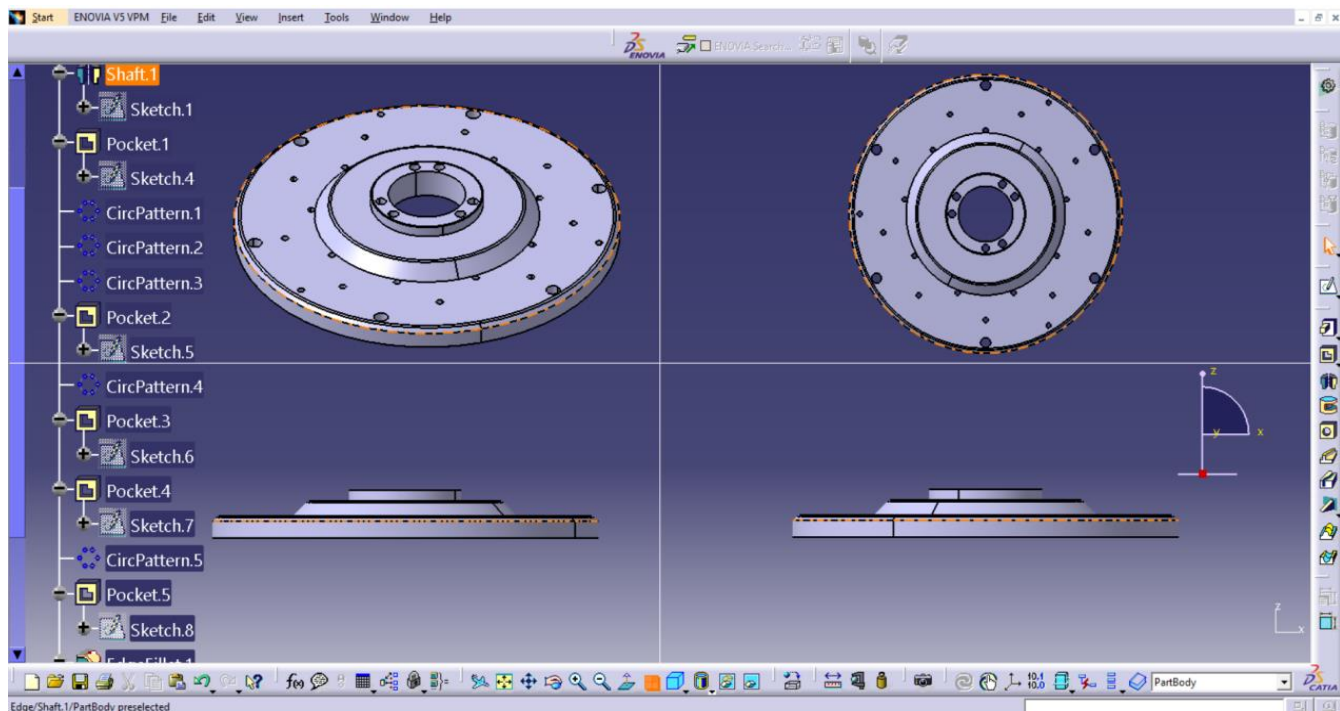

IV. LITERATURE SURVEY

1) **N. N. Suryawanshi, Prof. D. P. Bhaskar, S.R.E.S Kopargaon.**: The Dual Mass Flywheel (DMF) is primarily used for dampening of oscillations in automotive power trains and to prevent gearbox rattling. We explained detailed initial model of the DMF dynamics is presented. This mainly includes the two arc springs and two masses in the DMF and their behavior. An experimental the DMF model is compared to convention flywheel. Finally the observation of the engine torque using the DMF is discussed. For this purpose the DMF is manufactured and done experiment or testing to see the results. And then results are compare with the conventional flywheel.

2) **Ulf Schaper, Oliver Sawodny, Tobias Mahl and Uti Blessing.**: They explains the DMF along with its application and components. Afterwards a detailed model of the DMF dynamics is presented. This mainly includes a model for the two arc springs in the DMF and their friction behavior. Both centrifugal effects and redirection, force act radially on the arc spring which induces friction. The numerical method is used to measure model validation

4) **Bjorn Bolund, Hans Bernhoff, Mats Leijon.**: This paper explains the use of flywheel. Nowadays flywheels are complex construction where energy is stored mechanically and transferred to and from the flywheel by an integrated motor or generator. The wheel has been replaced by a steel or composite rotor and magnetic bearings have been introduced. By increasing the voltage, current losses are decreased and otherwise necessary transformer steps become redundant

5) **Jordan Firth, Jonathan Black.**: This paper explains the vibration interaction in a multiple flywheel system. Flywheels can be used for kinetic energy storage. In this paper one unstudied problem with vibration interaction between multiple unbalanced wheels. This paper uses a linear state space dynamics model to study the impact of vibration interaction. Specifically, imbalanced induced vibration inputs in one flywheel rotor are used to cause a resonant whirling vibration in another rotor. Vibration is most severe when both rotors are spinning in the same direction.

V. RESULT AND DISCUSSION

ANALYSIS RESULT OF CARBON STEEL:

TOTAL DEFORMATION:

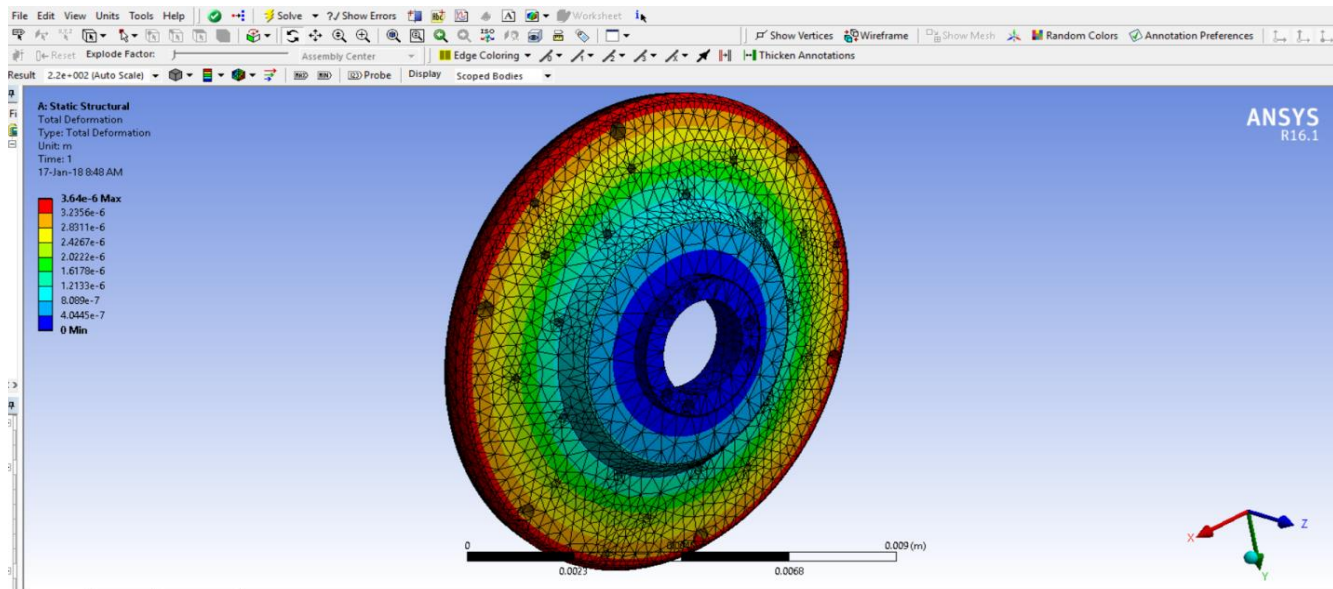

EQUIVALENT STRESS:

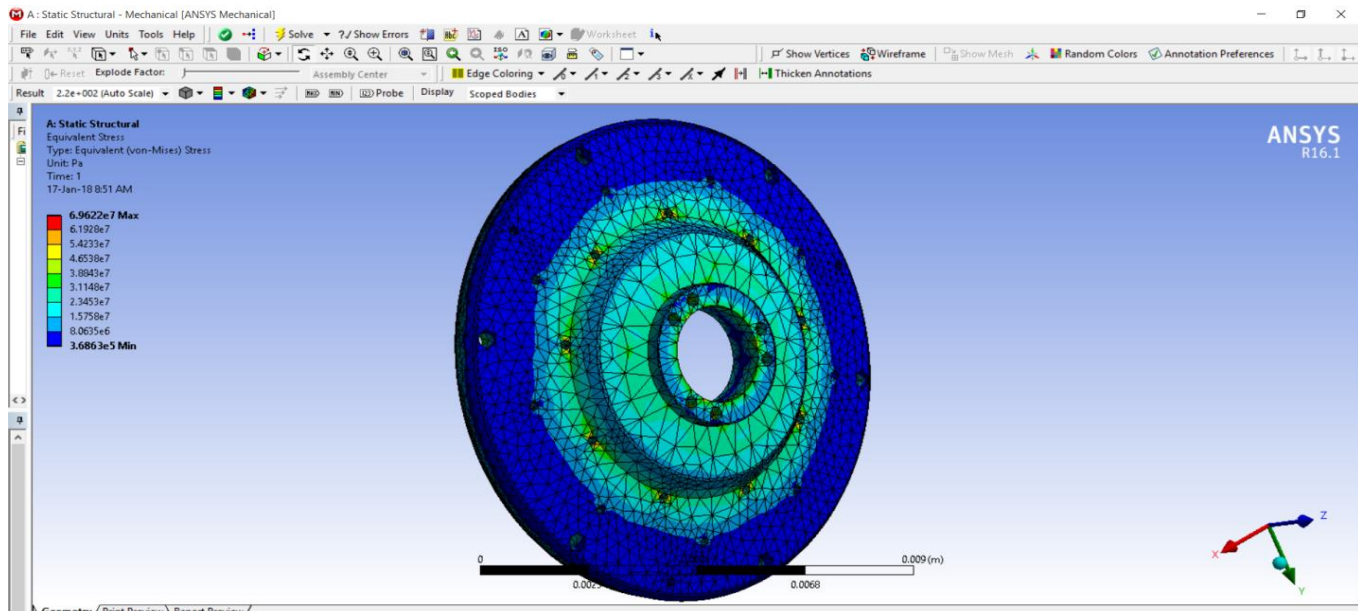

MAXIMUM PRINCIPAL STRESS:

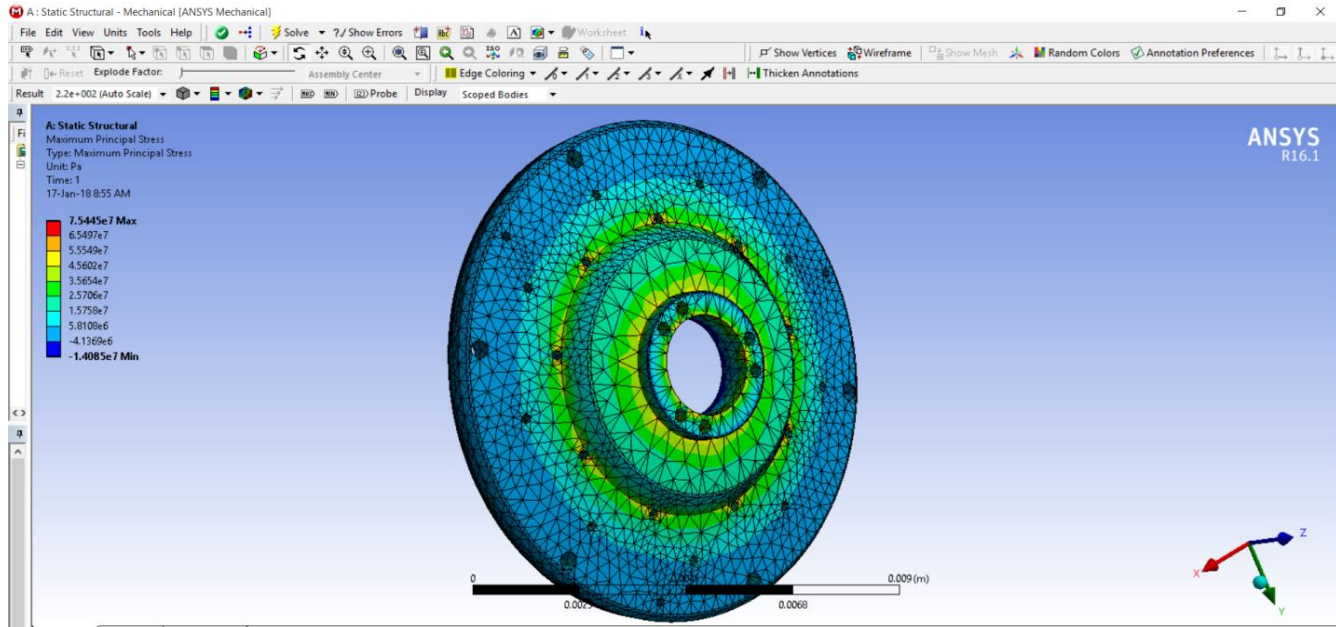

ANALYSIS OF ALUMINUM ALLOY: TOTAL DEFORMATION:

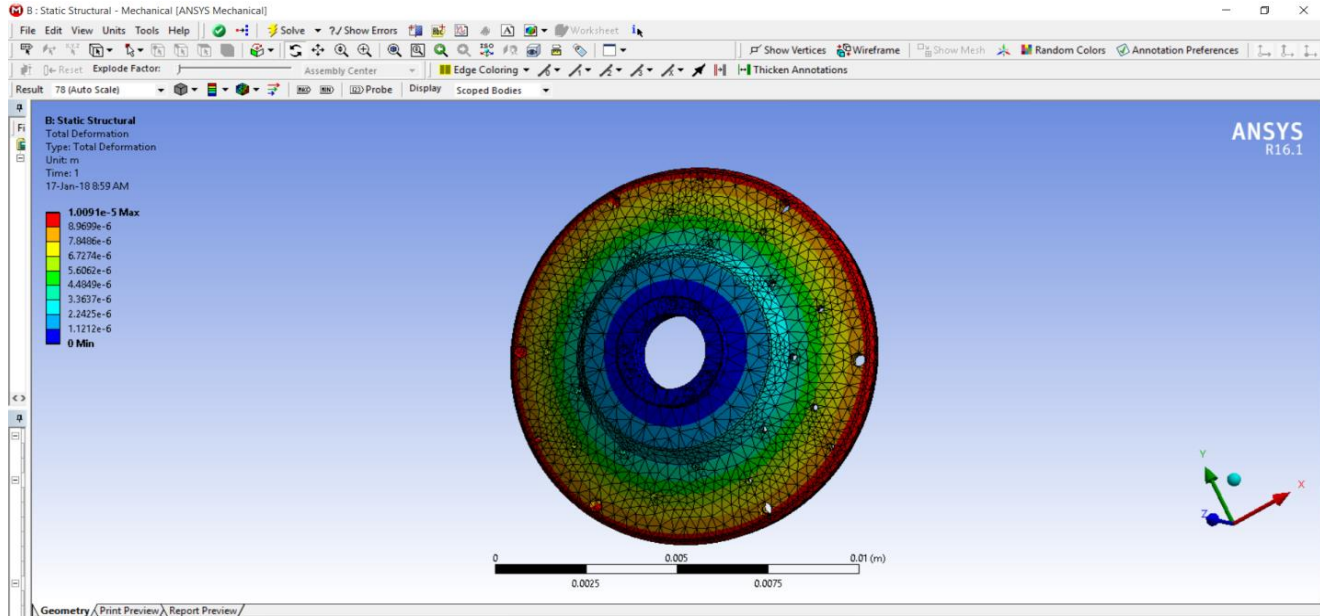

EQUIVALENT STRESS:

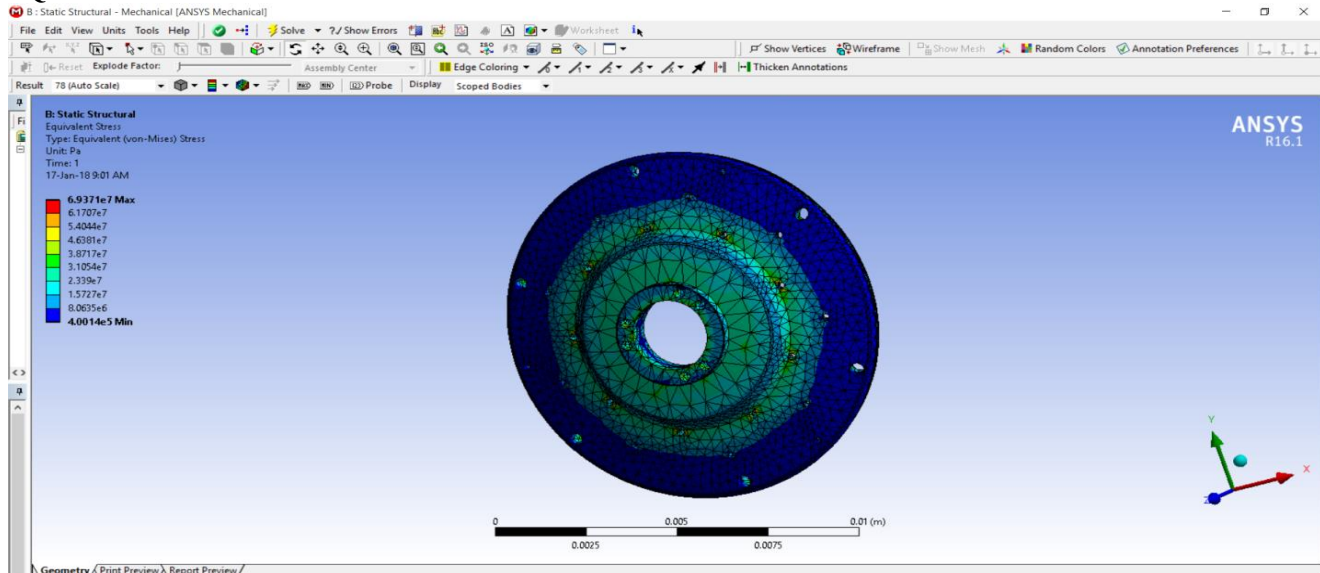

MAXIMUM PRINCIPAL STRESS:

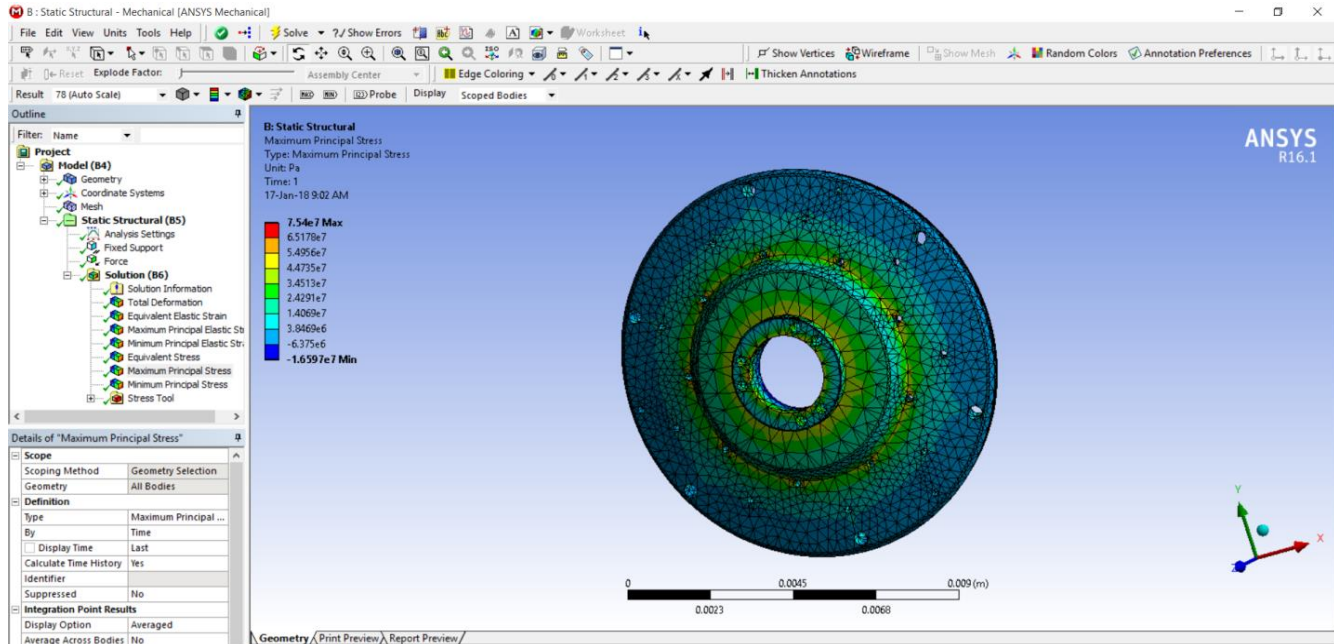

ANALYSIS OF BERYLIUM:

TOTAL DEFORMATION:

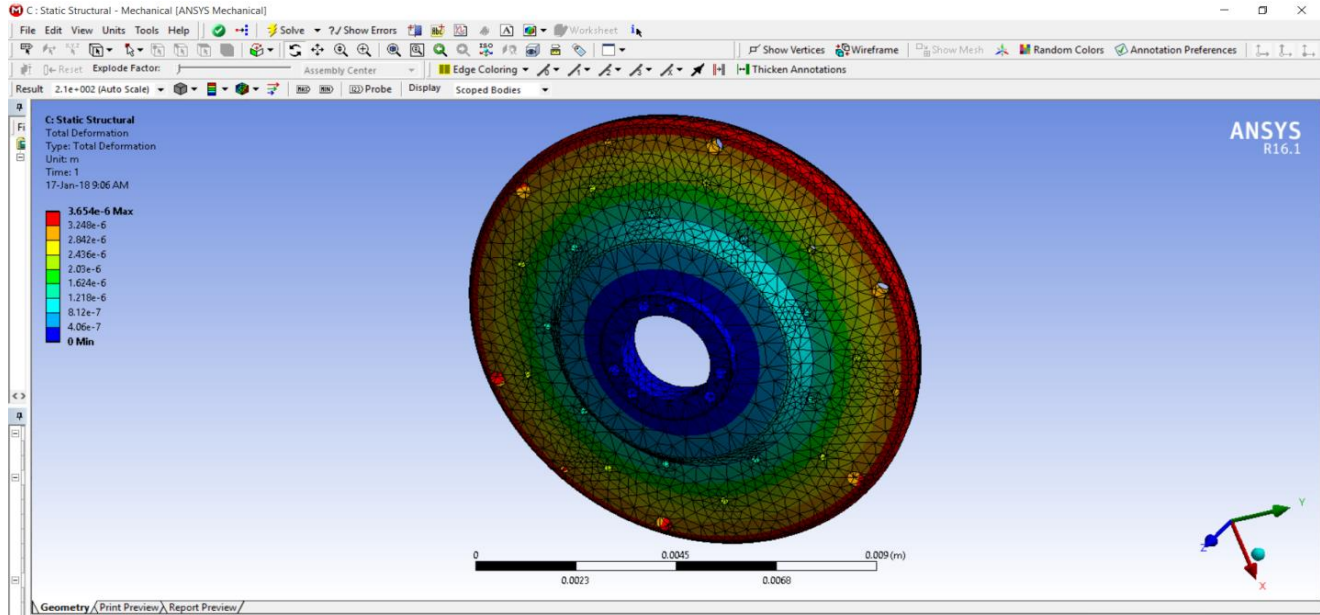

EQUIVALENT STRESS:

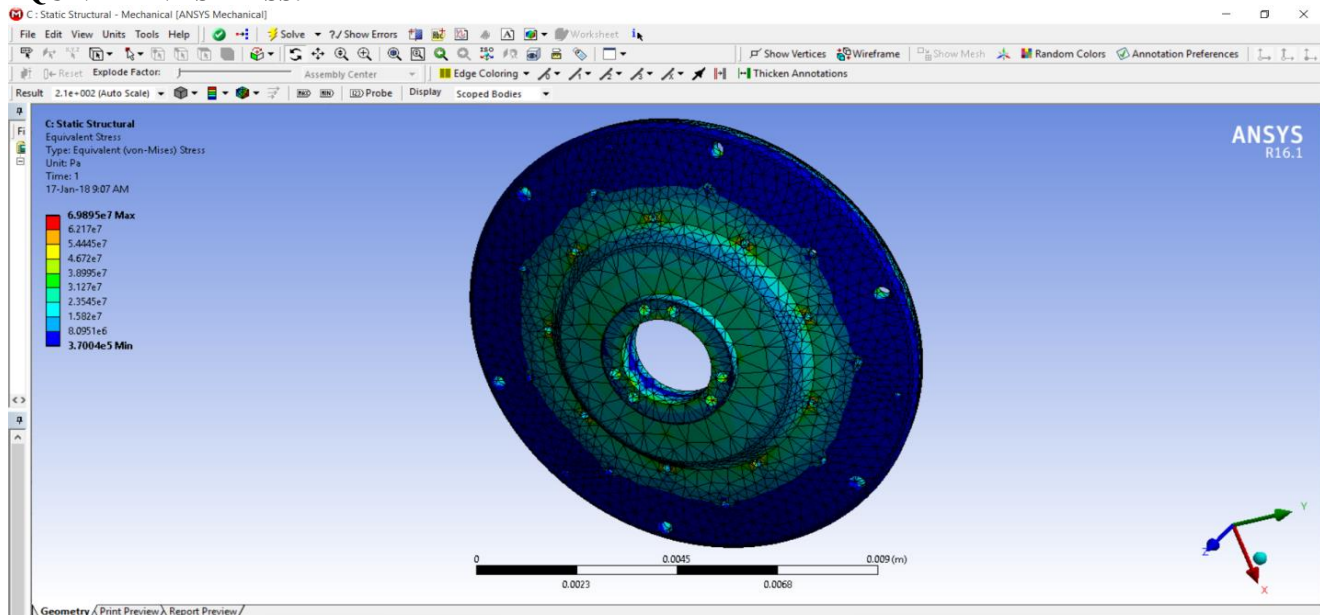

MAXIMUM PRINCIPAL STRESS:

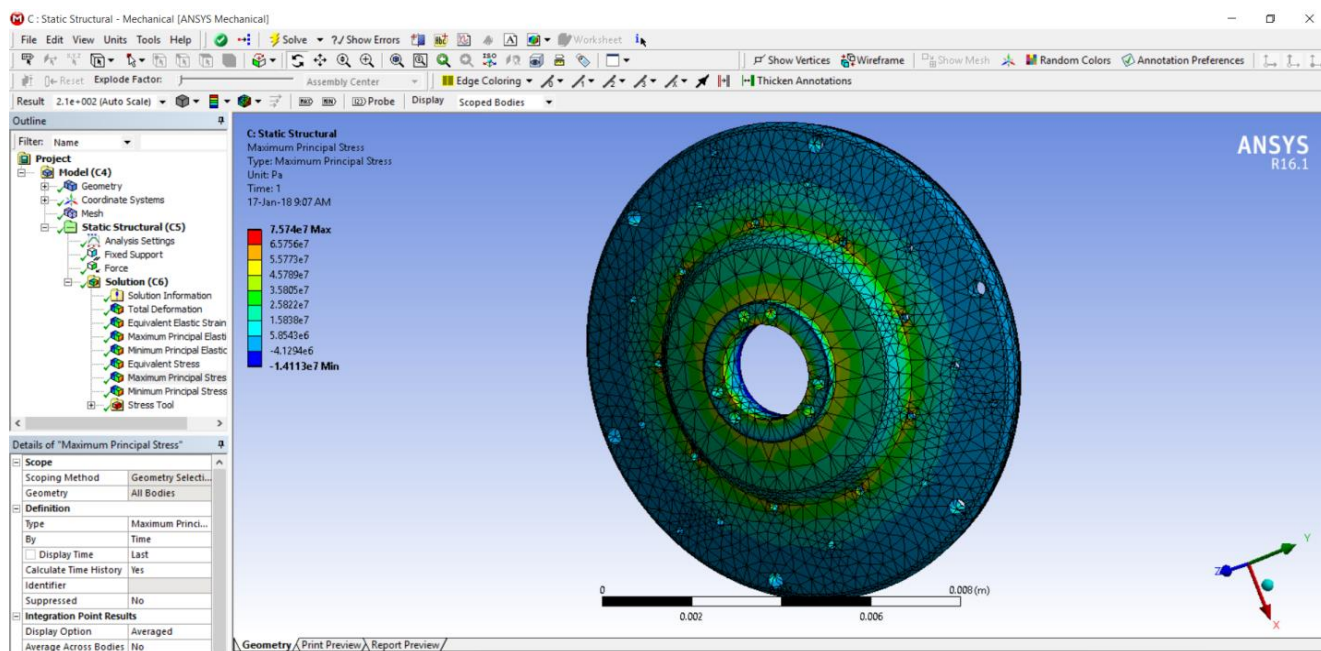

VI. CONCLUSION

Project is based on design, development and stress analysis of flywheel using different material. Flywheel is mechanical device which is used to store energy whenever required for machine or automobile etc. The amount of energy stored is directly proportional to square of its rotational speed. Here the failure due to the stress is find out by using the analysis method and development is made in design of the flywheel to rectify the failure. There are many causes of flywheel failure. Among them, maximum tensile and bending stresses induced in the rim and tensile stresses induced in the arm under the action of centrifugal forces are the main causes of flywheel failure. The different models of flywheel are developed for analysis. The analysis is carried out for different cases of loading applied on the flywheel and the maximum Von mises stresses and deflection in the rim are determined and the results are evaluated. And from the results we can see that the carbon steel stores more energy and can withstand more stress than other three materials but due to properties of the cast iron it is more largely used.

Result table:

S.NO	MATERIAL APPLIED	TOTAL DEFORMATION	EQUIVALENT STRESS		MAXIMUM PRINCIPLE STRESS	
			MAX	MIN	MAX	MIN
1.	CARBON STEEL	3.64e-6	6.962e7	3.686e5	7.544e7	-1.408e7
2.	ALUMINIUM ALLOY	1.009e-5	6.931e7	4.001e5	7.541e7	-1.659e7
3.	BERLIUM	3.65e-6	6.989e7	3.700e5	7.574e7	-1.411e7

VII. REFERENCES

1. Ulf Schaper, Oliver Sawodny, Tobias Mahl And Uti Blessing, "Modeling And Torque Estimation Of An Automotive Dual Mass Flywheel", American Control Conference, 2009.
2. Bjorn Bolund, Hans Bernhoff, Mats Leijon, "Flywheel Energy And Power Storage Systems", Renewable And Sustainable Energy Reviews, 11(2007) 235-258.
3. Jordan Firth, Jonathan Black, "Vibration Interaction In A Multiple Flywheel System", Journal Of Sound And Vibration, 331(2012) 1701-1714.
4. Paul D. Walker*, Nong Zhang, "Modelling Of Dual Clutch Transmission Equipped Powertrains For Shift Transient Simulations", Mechanism And Machine Theory, 60 (2013) 47-59.

5. Li Quan Song, Li Ping Zeng, Shu Ping Zhang, Jian Dong Zhou, Hong En Niu, "Design And Analysis Of Dual Mass Flywheel With Continuously Variable Stiffness Based On Compensation Principle", Mechanism And Machine Theory, 79(2014) 124-140.
6. Manuel Olivaresa, Pedro Albertosb "Linear Control Of The flywheel Inverted Pendulum", ISA Transactions 53(2014) 1396-1403
7. Akshay P. Punde, G.K.Gattani" Analysis of Flywheel" International Journal of Modern Engineering Research (IJMER)
8. Vipul Arora, Satish C. Sharma" Integration and Performance Analysis of Flywheel Energy Storage System in an ELPH Vehicle "International Journal of Recent Trends in Engineering, Vol. 1, No. 5, May 2009.
9. M. M. Flynn, J. J. Zierer and R. C. Thompson "Performance Testing of a Vehicular Flywheel Energy System" Center for Electro mechanics, The University of Texas at Austin, SAE technical paper series.
10. J.D. Herbst, S.M. Manifold, B.T. Murphy, J.H. Price "Design, Fabrication, and Testing of 10 MJ Composite Flywheel Energy Storage Rotors "SAE technical paper series.
11. Carlos M. Roithmayr "International Space Station Attitude Control and Energy Storage Experiment: Effects of Flywheel Torque" NASA/TM-1999-209100.
12. K. Ghedamsi, D. Aouzellage, E.M. Berkouk" Performance Anaslysis of a Flywheel Energy Storage System Associated to Variable-Speed Wind Generator " J. Electrical Systems(Research paper).
13. Shinichi Chiba, Kimihiko Aoyama and Kenji Yanabu, "Fatigue Strength Prediction of Truck Cab by CAE", Research paper.
14. Y. Liu and S. Mahadevan "Uncertainty Modelling in Fatigue Life Prediction", Department of Civil & Environmental Engineering, Vanderbilt University
15. Bruce E. Boardman, "Crack Initiation Fatigue-Data, Analysis, Trends and Estimation", SAE Paper # 820682, 1983.