



DESIGN & DEVELOPMENT STUDY OF PICK AND PLACE MECHANIZED SYSTEM

Prof. Husain Shaikh¹, Rohan Chewale², Rahul Dhebe³

¹Prof Mechanical Engineering Vidya Prasarini Sabha's College of Engineering and Technology ,Lonavala

²Student Mechanical Engineering Vidya Prasarini Sabha's College of Engineering and Technology ,Lonavala

³Student Mechanical Engineering Vidya Prasarini Sabha's College of Engineering and Technology ,Lonavala

ABSTRACT

Most of the small-scale handling equipment manufacturers in India is using manual methods or a finished product, material transfer, and pick and place operations which consume more time and reduced productivity. To remedy the above-mentioned problem the low-cost solution for pick and place operation uses electronic, electrical, and mechanical components. The project is suitable for thin sheet metal, intricate parts also have the capability for paper handling and has multiple speed control or operation.

Keywords: Pick And Place Machine, Automation, Mechanical, Suction.

1.INTRODUCTION

In today's Industry and shop floors, industrial automation is everywhere and it is difficult to imagine a production line without automation. Industrial automation uses control systems and equipment, such as computer software and robots, to perform tasks. These systems operate industrial equipment automatically, significantly reducing the level of operator involvement and oversight required. One machine/mechanism that is most visible in industrial automation is the Mechanical pick and Place mechanism. Pick and place automation speeds up the process of picking up parts or items and placing them in other locations.

Automating this process helps to increase production rates. Pick and place robots handle repetitive tasks while freeing up human workers to focus on more complex work. With a variety of design options available, pick and place machines can be configured with various end-of-arm tooling options for use in different applications, such as assembly, packaging, or bin picking. The Mechanical Pick & Place Machine, our project, aims to show the simple working of the mechanism.

Pick and the place is the act of picking things up from one location and placing them in another. Specific cases include:

Picking and placing is one of the major uses of industrial robots

In the context of electronics, SMT placement equipment

In the context of logistics, an automated storage, and retrieval system

2.LITERATURE SURVEY

Santosh C, Manoj C S [1], has designed and fabrication of pneumatic arm for pick and place of cylindrical objects. The handling of materials and mechanisms to pick and place of objects from a lower place to a higher place and widely found in factories and industrial manufacturing. There are number of pneumatic arms are available which consists of so many mechanisms hence become expensive. The designed pneumatic arm consists of two cylinders, a shaft works with lead screw mechanism capable of converting motion of piston to rotational motion of arm with help of using compressed air. The designed process are carried out based on integrated information of kinematics dynamics and structural analysis of the desired robot configuration as whole.

Here basically they explained about the pneumatic arms which of different types based on number of cylinders and the shaft can work and able to convert motion of piston to rotational motion of arm using belt drive.

Hardik A. Modi [2], has design the system for pick and place of machine components of CNC-Lathe. Automation is termed as the use of different control systems such as numerical control, programmable logic control or another industrial control system in concern with computer applications or information technology to manipulate all the industrial machinery and processes, thus reducing the need for human intervention. Automation plays a dominant role in the world economy these days and in daily application in industries.

Ravi Kumar Mourya, Amit Shelke, Saurabh Satpuite, Sushant Kakade, Monoj Botre [3], have main objective of their project are to design and implement a four DOF pick and place automation. To determine the end effectors position and orientation, theoretical analysis of inverse kinematics is carried out. Ansys software is used for FE Analysis. Prof. S.N. Teli, Akshay Bhalerao, Sagar Ingole, Mahesh Jagadale. This project aims to design and fabricate the pneumatic arm for pick and place of cylindrical objects. They conclude that arm is controlled by manually flow control and direction control valve. Arm rotation and movement is done by pneumatic cylinder using helical slot mechanism. Total arm weight is 25 kg. The model is expected to lift at least 10 kg weight. S. Premkumar, K. Surya Varman, R. Ballamurgan, Experimental aim is to collaborate the gripper mechanism and vacuum sucker mechanism working in single pick and place automation.

S.C. Gutierrez, R. Zotovic, M.D. Navarra, M.D. Meseguer. [4], Their purpose of work is to manufacture a light weight automation with a low-cost budget. They conclude that to avoid negative influence on the total weight of the arm, the plastic material reinforced with fiber is used and vacuum infusion man process is used for manufacturing. Local reinforced elements must be included during construction of arm shell. The mast light gear reducer, harmonic drive types are used but because of lack of alignment causes disassembly of gear package to avoid these flexible couplings are required. Gabrielle J.M. Tuithaf, Just L. Harder. Current automations are not safe for interaction with humans, especially for children therefore safe four DOF automation is develop.

Automation can perform tasks like gripping, sucking, lifting, placing, releasing, in a single automation arm. It will reduce the cycle time, Ideal time, cost of operation, space consumption. It is user friendly and effectively used in glass handling system.

M.Pellicciari, G. Berselli, F. Leali, A. Verganana. [5], the method for reducing the total energy consumption of pick and placed automations. It is seen that blowing down an operation as much as possible is not always beneficial. Energy consumption of given operation as a function of the task execution time. Future work includes improvement of the motor model, development of online programming algorithms. Analysis of speed, distance, load lifted by arm is done to know its performance. This automation expected to overcome the problem such as placing or picking object that is away from the user, pick and place hazardous object fast and easily.

John Iovine [6], in his book various aspects of designing an automation is described. It deals with different types of Arm design, controlling techniques, vehicle design etc. ER. Rajput, in this book the operation and control of automation is discussed. Arduino cookbook, in this book details and methods of interfacing hardware components such as Stepper motor and UNO Arduino, is been discussed.

M.Ciancietti, A.Arienti, B.M.Follador, B.Mazzalai, P.dario [7] they get inspired by the Octopus to and make an interesting model in automation due to its high dexterity, variable stiffness and very complex behavior. In this experiment they study the key features and patterns of movement of Octopus arm and this features and patterns and patterns of movement are that is elongation, shortening, bending and reaching etc. used for guide the movement of actuator. They conclude that the concept proposed for the mechanism at the base of the automation inspired to the Octopus muscular hydrostat where successfully implemented on mock-ups and the corresponding models have been modified and validate.

International Journal Of Science, Engineering And Technology Research (IJSETR) Paper On Pick And Place Robotic Arm Using Arduino By Harish K, Megha D, Shuklambari M, Amit K, Chaitanya K Jambotkar [8] For the application of packaging pick and place robot using Arduino mega. This is helpful for the Palletizing application.

International Journals of Environment and Sustainable Development (IJSETR) Paper on Multi handling Pick and Place Robot by S Premkumar, K Surya Varman.[9] The machine involves a combination of gripper and vacuum suck mechanism and Motion controlled using revolute joints for lifting, gripping, and placing several parts. This is a multi-head type PNP.

International Journal of Engineering Research and Development (IJERD) Paper on Design Analysis of a Remote Controlled "Pick and Place" Robotic Vehicle by B.O. Omijeh, R. Uhumwangho, M. Ehikhamenle Department of Electrical Engineering, [10] University of Port Harcourt the arm containing 5 degrees of freedom and wheels for the motion of the vehicle, this robot is remotely controlled for handling hazardous objects. Such robots usually have a SCARA configuration.

3.PROPOSED WORK

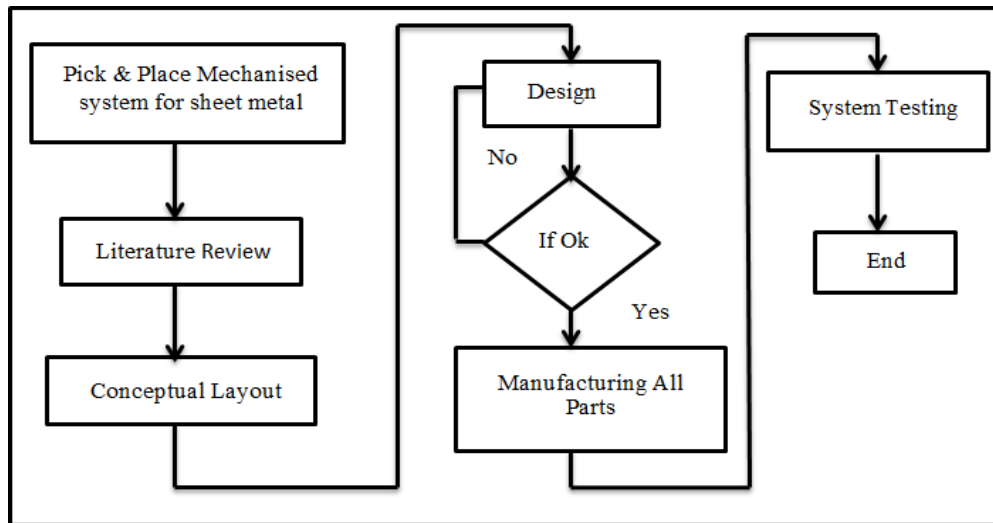

Fig3.1: Workflow of process Material Selection

Sr. No.	Material	Component
1	Mild Steel (AISI 1018)	Plate, Moving Arm
2	Aluminum	Supporting Discs, 4 bar mechanism
3	Nylon	Holding block of suction

Design Calculation

The height difference between the center of the motor and the center of the belt drive is 150mm = 0.15m.

The length difference between the center of the motor and the center of the belt drive is 85mm = 0.085m. $F = p.A$ (1) for pressure to hold objects

$F = mgh$(2) for force required to lift object

So.,

$P.A = mgh$

$$A = \frac{mgh}{P} = \frac{78 \times 45}{9.68}$$

$$A = 3510 \text{ mm}^2$$

$$= 0.00351 \text{ m}^2. (3)$$

□ Area of the mosquito coil stand is 0.00351 m² Weight = mass. Gravity = m.g

$$W = 200g$$

$$= 0.2 \text{ kg}.....(4) \text{ weight of coil}$$

$$H = 170 \text{ mm}$$

$$= 0.17 \text{ m}.....(5) \text{ based on the design of the plate } P. (0.00351) = (0.2) \cdot (0.17)$$

$$P = 9.68 \text{ kN/m}^2.$$

$$= 0.0968 \text{ bar} < 10 \text{ bar}$$

Calculation for Motor :-

$$\frac{Hz \times 60 \times 2}{\text{number of poles}} = \text{no-load RPM. } (60 \times 60 \times 2) / 4 = X$$

$$7,200 / 4 = 1,800 \text{ RPM.}$$

Note: 1. The frequency of the input power is determined most often by the electrical distribution system in

the country where the motor is being operated. The most common frequencies are 50 Hz and 60 Hz

no. of poles define as the no. of magnets used in motor

Design Calculation 4-bar Mechanism:

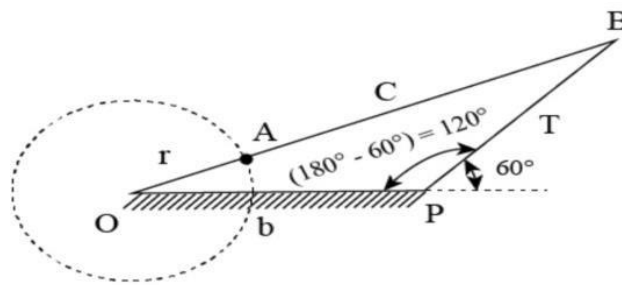

Case 1: higher Extreme position $\cos \theta = \frac{b^2 + (r+c)^2 - R^2}{2bR}$

2bR

$$\cos 120^\circ = \frac{200^2 - (r+c)^2 + 132^2}{2 \cdot 200 \cdot 132}$$

$$-0.5 = \frac{40,000 - (r+c)^2 + 17,424}{52600}$$

$$-0.5 = \frac{40,000 - (r+c)^2 + 17,424}{52600}$$

$$-0.5 = \frac{40,000 - (r+c)^2 + 17,424}{52600}$$

$$(r+c) = 293 \quad (1)$$

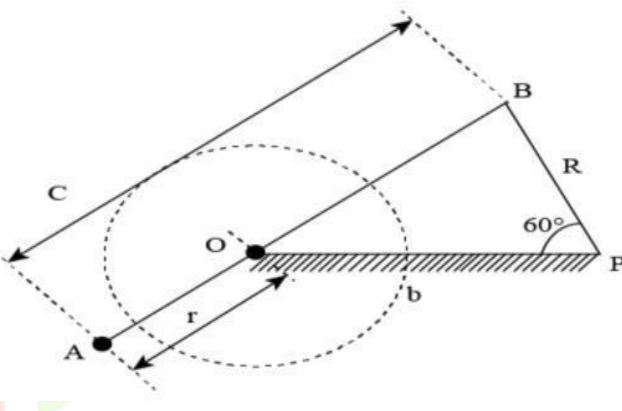
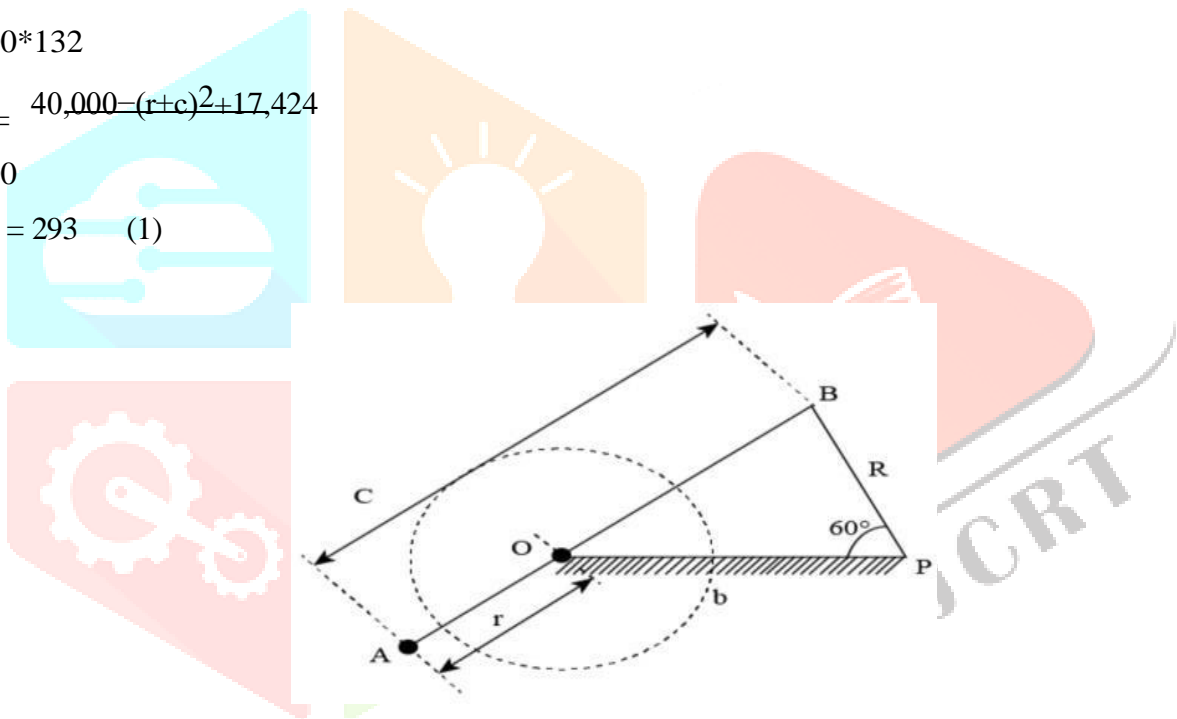

Case 2: Lower Extreme position $\cos \theta = \frac{b^2 + (c-r)^2 - R^2}{2bR}$

2bR

$$\cos 60^\circ = \frac{200^2 - (c-r)^2 + 132^2}{2 \cdot 200 \cdot (c-r)}$$

$$0.5 = \frac{40,000 - (c-r)^2 + 17,424}{400(c-r)}$$

$$0.5 = \frac{40,000 - (c-r)^2 + 17,424}{400(c-r)}$$

$$400(c-r)$$

$$(c-r) = 167 \quad (2)$$

Now addition of eq 1 & 2

$$r + c = 293 \quad (1)$$

$$c - r = 167 \quad (2)$$

$$c + r = 293$$

$$+ c - r = 167$$

 $2c = 460$

$$\therefore c = 230 \text{ \& } r = 63$$

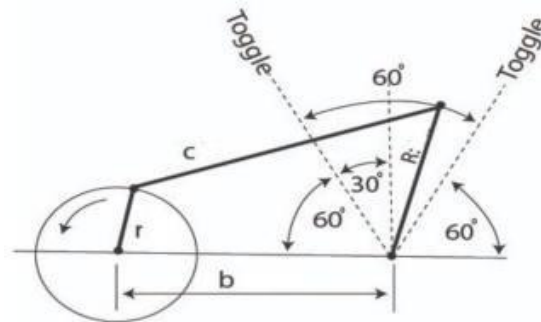

Design Calculation Belt drive: -

Diameter of Driven Pulley: - $d_2 = d_1 n_1 / n_2$ Diameter of Driver Pulley: - $d_1 = d_2 n_2 / n_1$

As we know that, $T = (F_2 - F_1) r_a$

Where, T = torque (Nm), F = force (N), r = radius of wheel or pulley

The available power can be expressed as $P = T \omega_a = (F_2 - F_1) r_a \omega_a$

Where, P = power transmitted (watts), a = angular velocity (rad/s)

RPM at the driven pully

$\frac{\text{RPM in}}{\text{RPM out}} = \frac{\text{Dia. out}}{\text{Dia. in}}$

$$1800 \frac{\text{RPM}}{\text{RPM out}} = \frac{7 \text{ cm}}{10 \text{ cm}}$$

$$\text{RPM out} = 2571 \text{ RPM}$$

$$\text{RPM out} = 2571 \text{ RPM}$$

Conceptual Design

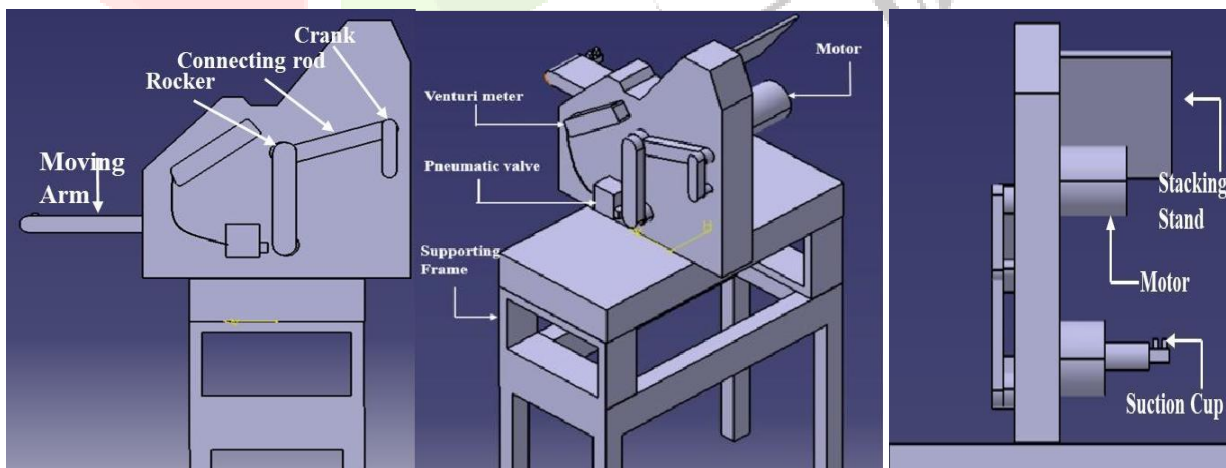

WORKING

The prototype uses the working principle of the four-bar mechanism.

A motor will rotate the crank and because of that linear movement of the slider is done.

The main working frame is connected to the slider which can do the movement of the arm for pick and place in a specific direction and angle required.

To the system head a vacuum pressure is used in suction cups to pick the components and then release them onto the target position.

RESULT

Design and development of mechanism at low cost with the study of space availability and application. The design is mechanized for proposed work within given constraints.

CONCLUSION

This system can be mostly cost efficient as compared to industrial pick and place robots.

This system can be used for picking and placing operation of different sheet metal components.

We can use this system for the operation of picking and placing of objects such as carton boxes, plastic components, leather parts etc.

REFERENCES

1. Arka Sain, Janardan Dattani, and Dhara M Mehta, "Design and Implementation of Wireless Control of Pick and Place Robot Arm", International Journal of Advanced Research in Engineering and Technology (IJARET), p-ISSN: 0976-6480 and e-ISSN: 0976-6499, Volume 9, Issue 3, May – June 2018.
2. M.J.Sawarkar, TruptiR.Raut, Nutan P. Nemad, Sonal C. Meshram, Pournima P. Tabhane, "Pick and Place Robotic Arm Using Android Device", International Research Journal of Engineering and Technology (IRJET), e-ISSN: 2395-0056 and p-ISSN: 2395-0072, Volume: 04, Issue: 03, Mar-2017.
3. M.T. Islam, M.A. Wazed and T.Mohammad, "Design and Fabrication of a 5 DOF Dexterous Robotic Arm for Industrial Tasks", International Conference on Mechanical Engineering 2007, ICME07-AM-58, 29-31 December 2007.
4. L. Xu, W. Zhou, X. Li, Wet gas flow modeling for a vertically mounted Venturi meter, Meas. Sci. Technol. 23 (4) (2012), 0453.
5. Anil S. Maheshwari, Arpana Gangurde, Sachin Kadam, Gaurav Gangurde, Shubham Rathod, Department of Mechanical Engineering Design of Pneumatic Pick and Place Automation for Groove Grinding Machine, International Journal of Advance Research in Science and Engineering, 07 (2018) 655.
6. S.N. Teli, Akshay Bhalerao, Sagar Ingole, Mahesh Jagadale, Kiran Kharat, Design and Fabrication of Pneumatic Robotic Arm, International Journal of Scientific & Engineering Research, 03 (2017)126.
7. Ardhendu Prasad Nanda, Design & Development of a Two-jaw parallel Pneumatic Gripper for Robotic Manipulation, National Institute of Technology Rourkela, Project Thesis, Department of Mechanical Engineering.
8. B. Mirtich, Y. Zhuang, K. Goldberg, J. Craig, R. Zanutta, B. Carlisle, and J. Canny, "Estimating pose statistics for robotic part feeders," in Proceedings of IEEE international conference on robotics and automation, vol. 2. IEEE, 1996, pp. 1140–1146.
9. Masri Ayob and Graham Kendall. (2005) "A Survey of Surface Mount Device Placement Machine Optimization: Machine Classification", Computer Science Technical Report, School of Computer Science and Information Technology, University of Notting.