



Sensor-Based Domestic Waste Management

¹Vishesh Jindal, ¹Prakhar Jain, ¹Shivansh Mishra

¹Student

¹Department of CSE (DATA SCIENCE)
Meerut Institute of Engineering and Technology
Meerut, India

Abstract: The growing human population is putting a lot of pressure on environmental resources. Poor waste separation results in most reusable items becoming trash. When waste isn't sorted correctly, it mixes together, causing harmful effects and damage to the environment and surrounding areas. A Smart Bin can sort waste automatically without human help. It can also inform the waste collection depot when it is full. Technology has consistently made our lives easier. This unique approach can change the waste management system and help us work toward a cleaner India. The main goal is to separate trash into different smart bins and send details to the collection depot once each bin is full. By placing these bins in various locations, we can improve the collection system instead of just following set routes. Research shows that using monitoring systems for smart waste bins can reduce solid waste collection costs by up to 37.3%. to Dec 2014.

Index Terms - Smart Waste Management, Sensor Based Waste Bin, LGMC, Waste Collection, Smart Bin, Waste Segregation.

Introduction

A increasing population results in an exponential increase in waste generation. Multiple waste types require specific handling methods to efficiently use resources and address problems such as the spread of diseases, sanitation, and harmful emissions. Nonetheless, amidst the hustle of everyday life, trash is frequently discarded carelessly. This presents challenges for municipal workers, who typically sift through the waste manually, often without protective gear, which poses health hazards. Initiated by the Government of India in 2014, the Swachh Bharat campaign seeks to promote cleanliness throughout the nation. Smart Trash Bins could serve as an efficient and budget-friendly way to improve waste management. (1)

In the organic part of Domestic Waste, which mainly contains food and garden waste, a method called anaerobic decomposition is used. While recycling works well for items like glass, metal, and plastic, it's important to note that even the waste we carelessly throw away can be used for energy production, organic fertilizers, or other useful products. Waste management goes beyond just picking up trash from various places. It involves collection, transportation, handling, reuse, disposal, and oversight. Many factors must be considered, including financial, environmental, technical, legal, political, and institutional issues. Waste production is rising, and its characteristics are changing due to population growth, industrial development, and living conditions, particularly in urban areas. The idea of "smart cities" has driven the development and use of new methods to improve the management of regular solid waste and create cleaner urban environments.

The concept of IoT has allowed for better management of products throughout their lifecycles. It helps optimize collection routes and implement smart waste collection systems. These systems often use sensors, microcontrollers, and communication modules like GSM and WiFi. These components work together to automate and simplify the waste management process. (2)(3)(5)(9)

I. COMPONENTS OF SMART BINS

The typical parts of the systems include microcontrollers, sensor systems, and GSM modules, such as Wi-Fi modules. The hardware components used in the system consist of infrared, photoelectric, RFID, ultrasonic sensors, and weights. The main problem is processing and garbage collection. For practical absence several factors are responsible for the recycling of waste system: absence of an appropriate framework in distinguished waste collection system and recycling. Absence in the representation of a separate waste collection productively and economically.

Also the motivation for the low level of population, particularly because of the last two elements. Consequently, the principal task is to answer for the recycling, segregation of garbage collection and implementation of a system. As in India is working on discovering a price-efficient framework that will not just get back funds for garbage removal and its arrangement of appropriate model. From the infrastructure of the waste filtering it is also dreamed to gain profits from the waste.

The SMART bin constantly checks its fill level with an ultrasonic sensor. This sensor measures the distance between the waste surface and itself to determine if the bin is full. When the bin reaches its maximum capacity, the system automatically sends a real-time alert to the LGMC monitoring system for quick waste collection. At the same time, a buzzer sounds twice to signal that the bin is full and no more waste should be added.

To ensure the readings are correct, the system considers the breakdown of organic waste, which may cause the waste level to drop over time. Periodic sensor readings are taken to confirm whether the apparent decrease in level is due to decomposition or the addition of new waste. This process helps maintain reliable monitoring and prevents false alerts.



Fig. 1. Locating the bin using sensors

Durable plastic is used for the outermost surface. Two separate layers are made for the different kinds of waste in electronics and sub bins. The sub bins can be easily removed for wiping off. A tray mechanism and a dual motor are used for design. Then the common waste tray is used for discarding the waste into it which is the sole section visible to the end person. IR sensor is used to detect this. (2),(6),(9)

II. DESIGN OF SMART BIN

- After this moisture sensor is activated which we fixed on the tray. For the classification of wet and dry waste, a present threshold value is used. In case the value measured on the moisture sensor is above the desired reading then it will be categorized as either dry waste or wet waste. Once the kind of waste is determined, the other step is to ensure that the appropriate sub-bin is used for the disposal. The mechanism of the servo motor is installed for this verification.
- An accurate angular movement 100 degrees clockwise or anticlockwise is required by the servomotor to slant the tray until the waste is completely discarded. For each bin on the side at a mediate complete level, an IR proximity sensor will be used. Now when the waste has accumulated to this stage,

the sensor will read and turn on the Global System for Mobile Communications (GSM) module to give alerts in the nearest waste collection hub or the holder of the smart bin owner to empty the sub bin.

- At the heart of the system is the Arduino Mega 2560. It controls all the sensors in the Smart Bin. The DHT11 sensor combines moisture detection and thermal resistance. It helps identify wet and dry waste. The MG995 servomotor adjusts the angle of the plate to direct waste into the right sub-bin for wet or dry materials. There are two servomotors that perform this task. An IR proximity sensor detects whether waste is present on the plate. This allows the system to stay idle when no waste is added, which saves energy. (1)(7)(8)
- When the bin is full, a buzzer alarm alerts the user to stop adding more waste.(1)
- A 12 V lithium-ion rechargeable battery pack powers the entire system.(1)

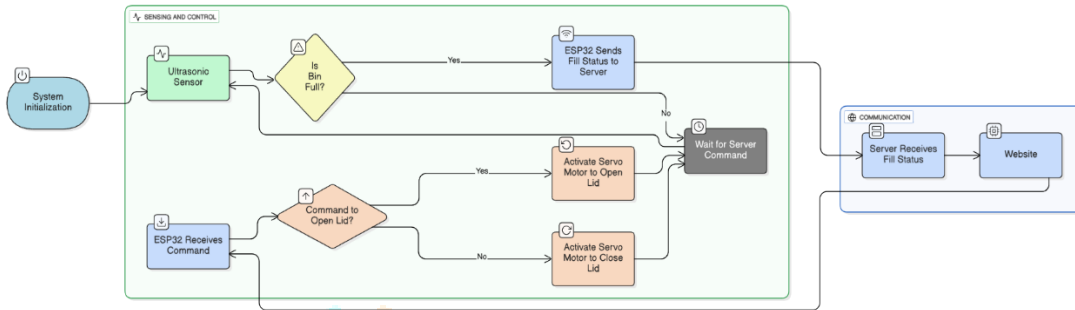

Fig. 2. Smart Bin Design

III. ANALYSIS OF DATA SYSTEMS

Improving the logistics of separate waste disposal with IoT (Internet of Things) technologies can save money and motivate people to separate their waste. This approach addresses issues like overloaded containers and delays in garbage removal. Each of these technologies has its own advantages and disadvantages, which may suit different situations. (3)



Fig. 3. Truck with the waste – This can be design of the truck in which waste is putted also sign drawn on it shows that the waste is recyclable and the blue bin in this is for non-biodegradable and red bin for biodegradable waste

IV. MANUAL POWER OPTIMIZATION

Actual data regarding the distances between the designated locations were employed for the calculations(4).

- In the typical garbage collection process, a truck follows a set route to service all containers in a residential area. The cleaning areas are divided into zones, which are visited in this order: 8, 4, 3, 2, 1, 6, 5, 9, 7, and back to 8. The total cost for this route is 1000. This amount serves as the starting point for exploring a better route.(3)
- Supplementary data for the computation (the calculations are based on the mean performance figures for truck operations).(13)
- Fuel cost - 90 per litre.
- Average fuel consumption - 8 litres per 100 kilometres.
- The maintenance expense - 50000 annually, assuming an annual Running of 20,000 kilometers.

Task: Find the best routes for garbage collection and the related costs based on container fullness data. A container is full when its fill level is 80% or more. You only need to visit a collection area if there is a container with a fill level of 80% or higher. If not, the area can be cleaned without any action needed.

- Calculating the travel cost for each route uses the following formula:
Travel Cost (W_{ij}) = Route Length (d_{ij}) * ((1 + Traffic Factor (k)) * (Fuel Consumption ($fuel$) / 100) + Maintenance + Depreciation)
- Here, ' d_{ij} ' denotes the distance from zone i to zone j , measured in kilometres. The traffic factor ' k ' affects mileage. When conditions are good ($k = 1$), the mileage is 12.5 Km/L. But if the traffic factor is 0.3, the mileage decreases to 9.6Km/L. (3)
- To optimize the route, we will use the boundary and branch method to find the Hamiltonian path.(3)
- Our research show that significant cost savings can be achieved by closely monitoring the waste levels of bins and sending the pickup vehicle along the most efficient route.
- If the algorithm predicts that the vehicle will not be filled to an acceptable level after visiting all the designated locations, we will adjust the route to maximize the vehicle's fill capacity.(3)(10)

V. OBSERVED RESULTS

The Smart Bin regulatory system is designed to activate only when an individual deposits waste onto the bin. After a brief two-second delay, the material in the bin goes through a thorough check to ensure it is sorted correctly.(1)

To test the segregation of dry waste, various items including plastic, wrappers, thermocol packaging, paper, and cardboard were used. After a two-second analysis, these materials were correctly sorted into the dry waste sub-bin. In the case of wet waste segregation, items such as spoiled food, vegetable pieces, and fruit peels were tested and similarly sorted accurately into the wet waste container. Additionally, should the sub-bins reach an 80% capacity level; the IR sensor transmits a signal to LGMC, initiating a buzzer alarm. (7)(10)

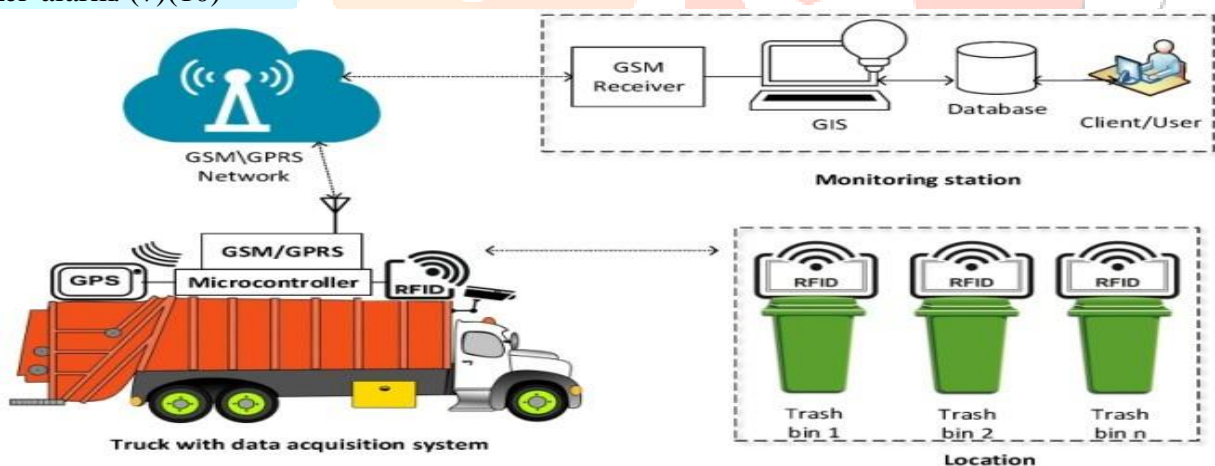

Fig. 4. Monitoring station to monitor the bins filling and send the trucks to unload them through GPS- At LGMC the user is there with all the database to know which all the bins are full and needs to be unloaded and so truck driver is explained all about procedure and the ins can be unloaded without any difficulty

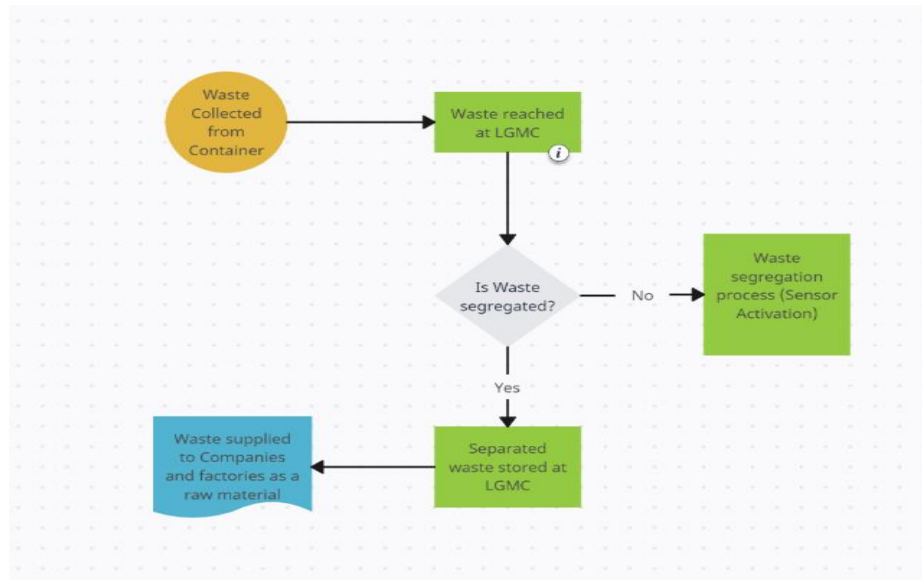

Fig. 5. Flowchart of the working of waste management system- firstly the waste is collected from containers and then it reaches LGMC, now it is checked if the waste is segregated then it is stored at LGMC and later it is sent to companies and factories for raw material and if not segregated then it can be sent for further waste segregation process

VI. FUTURE PROSPECTS

At present, the Smart Bin system is tailored for the separation of dry and wet waste. However, future enhancements can include the capability to identify metallic and electronic waste by incorporating a capacitive sensor.

To further advance this automation, we can develop an HTML based website. This website will offer the public the convenience of scheduling waste pickups from their residences, allowing them to select their preferred date and time for collection.

VII. BENEFITS

- Streamlined Waste Collection and Automatic Sorting of Waste into metal, dry, and wet categories.
- Reduced Time Consumption.
- Efficient Resource Utilization.
- Promotes a Cleaner Environment. (9)

REFERENCES

- [1] Manisha Jayson, Sanket Hiremath, Lakshmi H.R.. "SmartBin-Automatic waste segregation and collection", 2018 Second International Conference on Advances in Electronics, Computers and Communications (ICAEECC), 2018.
- [2] Puppala Ramya, V Ramya, M Babu Rao, 'IoT-based Household Electronic Waste Management Systems for Electronic Waste Collection'.
- [3] Julia Yamnenko, Vasyl Kurdecha, Nataliia Gvozdetska., "Domestic Solid Waste Disposal Logistic Optimization Using Internet of Things Technologies".
- [4] Dr.V.Muneeswaran, Dr. P. Nagaraj, Bandi Arun Kumar Reddy, Mellampudi Yuva Vardhan, Thummala Naveen Kumar Reddy, Reddy Sanjay, 'Power Generation using Waste Management System'.
- [5] Julia Yamnenko, Vasyl Kurdecha, Nataliia Gvozdetska, 'Domestic Solid Waste Disposal Logistic Optimization Using Internet of Things Technologies'.
- [6] R. Seetharaman, S.Vidhul Dakshin, R.R.Sreeja, N.Nivetha, K.Anandan, 'Arduino based System for Domestic Waste Water Management using pH Sensor'.
- [7] T.M.B.Shankar Balu, R.S.Raghav, K.Aravinth, M.Vamshi, M.E.Harikumar, Rolant Gini J, 'Arduino based Automated Domestic Waste Segregator'.
- [8] R.Rathna, 'Smart Waste Management Scheme using IoT for Metropolitan Cities'.
- [9] Tran Anh Khoa, Cao Hoang Phuc, Pham Duc Lam, Le Mai Bao Nhu, Nguyen Minh Trong, Nguyen Thi Hoang Phuong, Nguyen Van Dung, Nguyen Tan-Y, Hoang Nam Nguyen, Dang Ngoc Minh Duc, "Waste Management System Using IoT-Based Machine Learning in University".
- [10] R. Sharan, S. Yiqiao, W. Seung-Hoon Hwang "A survey on LPWA technology: LoRa and NB-IoT".