



REAL TIME WEATHER REPORT STREAMING WITH GRAPHS USING IOT

B.Harish¹, P.Ganesh², V.Anil³, MD.Chand pasha⁴, Shilpa.K⁵

^{1,2,3,4} B.tech final year students, Department of Electronics and communications Engineering.

⁵Assistant Professor, ECE Department, JBIET, Hyderabad, Telangana.

J B Institute of Engineering and Technology, Hyderabad, Telangana.

ABSTRACT

This study presents the development and implementation of an Arduino-based weather station leveraging Internet of Things (IoT) technology for real-time environmental monitoring. The system is designed to measure and log critical weather parameters, including Air Quality/Gas Detector, rainfall detection and temperature, humidity, atmospheric pressure using sensors such as the BMP280. The data collected is transmitted via an ESP32 Board to the Thing Speak IoT platform, enabling remote access to real-time weather information from anywhere in the world. The weather station is particularly suited for applications in agriculture, disaster management, and controlled environments such as industrial and residential areas, where continuous monitoring of climatic conditions is essential. The recorded data not only supports real-time decision-making but also aids in analysing weather patterns and studying climate changes. This implementation highlights the potential of integrating IoT with microcontroller-based systems to create cost-effective, accessible, and reliable weather monitoring solutions.

1.INTRODUCTON

In recent years, the rapid advancement of the Internet of Things (IoT) has transformed traditional systems into intelligent and automated solutions across various domains, particularly in agriculture and environmental monitoring. Weather conditions such as temperature, humidity, rainfall, and soil moisture play a critical role in determining crop productivity and environmental sustainability. Accurate and real-time monitoring of these parameters is essential for making informed decisions and improving efficiency in agricultural practices.

Conventional weather monitoring systems are often limited by manual data collection, lack of real-time access, and absence of proper visualization tools. These limitations make it difficult for farmers and researchers to analyze environmental trends and respond promptly to changing conditions. Furthermore, traditional systems do not provide continuous monitoring or remote accessibility, which reduces their effectiveness in modern applications.

The integration of IoT technology addresses these challenges by enabling real-time data acquisition, transmission, and visualization. IoT-based systems utilize sensors to collect environmental data and microcontrollers such as NodeMCU or Arduino to process and transmit this information to cloud platforms. These platforms, such as ThingSpeak or Blynk, allow users to visualize data in the form of graphs and dashboards, making it easier to interpret patterns and trends over time.

The concept of real-time weather report streaming with graphical representation enhances user understanding and supports data-driven decision-making. Graphical visualization not only simplifies complex data but also helps in identifying variations and predicting future conditions. This is particularly beneficial in smart agriculture, where timely decisions regarding irrigation, fertilization, and crop management can significantly impact yield and resource utilization.

This paper presents the design and implementation of an IoT-based real-time weather monitoring system that streams environmental data and displays it using graphical representations. The proposed system aims to provide a cost-effective, scalable, and user friendly solution for continuous weather monitoring and analysis, thereby contributing to the development of smart and sustainable agricultural practices.

2. LITERATURE REVIEW

The author elaborates how the weather prediction system is becoming a crucial challenge in every weather extreme event that causes an adverse effect of the system on lives and property as well. Hence the accuracy of weather data is being one of the critical challenges to enhance the weather prediction skills and build up the resilience to effect of detrimental weather report condition. The author describes that Uganda and various other developing countries have looked challenges in developing timely & accurate weather data due to scarce weather observation. The scarce weather monitoring is a part of the high cost of developing automatic weather stations. The restricted funding is available to national meteorological services of the respective countries. In this proposed system the author firstly takes care of the problems and then applies them.

In this paper [2], the author presents an IoT-based weather monitoring system. In this research, the environmental parameter can be retrieved through sensors. The author uses a different sensor to scale the various parameter like humidity, temperature, pressure, rain value & the LDR sensor is used. The system also calculates the dew point value from the temperature prototype. The temperature sensor can be used to measure the value of the particular area, room, or any place. With the help of the LDR sensor, the light intensity can be used as described by the author. The author in this used an additional functionality of the weather monitoring as SMS alert system based on the exceed the value of the sensing parameters as temperature, humidity, pressure, light intensity, and rain value. The author also adds an email and tweet post alerting system. The author in this system uses node MCU 8266, and various sensors.

In this paper [3], the author represents a low-cost live weather monitoring system using OLED display, in which the author displays the various fields where the IoT has produced innovative things in the system. The author described A new revolutionary system. Which measures the real-time Weather's condition. The monitoring weather situation is very much helpful for everyone either for farmer or industry or daily working people or for school as well. So, the author by developing a live weather monitoring system reduced the difficulty level for farmers and industry as well. In this paper, the author uses an OLED display that will display the weather conditions and In the proposed model, the author uses an ESP8266EX microcontroller-based WeMos D1 board executed on Arduino, that retrieved the data from the cloud. WeMos D1 is a wifi module that is developed on ESP8266EX microcontroller. It has a 4MB flash memory. It one of the Excellent which is programmed with node MCU and Arduino ide. In this paper Author uses only two gadgets to measure the weather conditions i.e., Wemos and OLED, After the connection, it will store the data on the cloud for storing data a thingspeak website is used to display the data regarding weather. The system displays the data on OLED and thing speak cloud. The author's aim is to obtain live information on weather conditions on OLED display.

3.METHODOLOGY/SYSTEM DESIGN

The proposed system follows a structured approach to collect, transmit, process, and visualize real-time weather data using IoT technology. The methodology is divided into multiple stages, ensuring efficient data acquisition and real-time monitoring.

Initially, appropriate environmental sensors such as DHT11/DHT22 for temperature and humidity, and BMP280 for atmospheric pressure are interfaced with a microcontroller unit (ESP8266 or ESP32). These

sensors continuously measure environmental parameters at predefined intervals. The microcontroller reads the analog/digital signals from the sensors and converts them into meaningful data using embedded programming.

3.1 BLOCK DIAGRAM

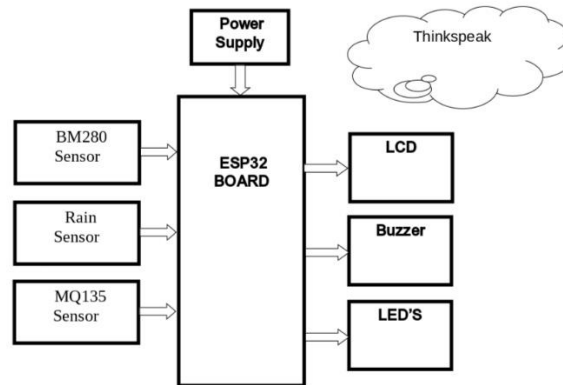

FIGURE 1: BLOCK DIAGRAM

In the next stage, the processed data is transmitted to a cloud platform through a Wi-Fi module integrated within the ESP device. Communication protocols such as HTTP or MQTT are used to ensure reliable data transfer. The cloud platform (e.g., ThingSpeak or Blynk) acts as a data storage and processing unit, where incoming data is logged and organized systematically.

Once the data is uploaded, the cloud platform generates real-time graphical visualizations such as line charts representing temperature, humidity, and pressure variations over time. These graphs are automatically updated as new data arrives, enabling continuous monitoring.

4.RESULT

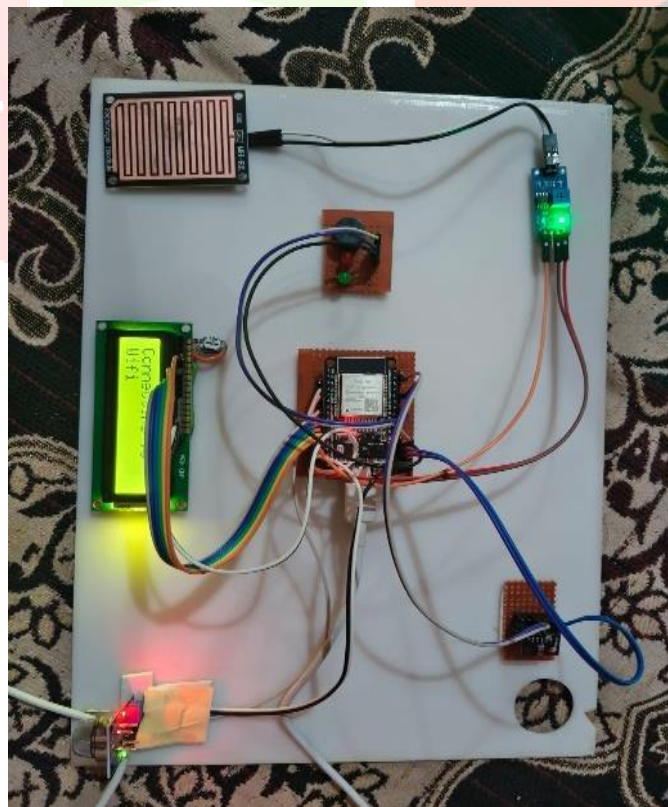

FIGURE 2 : Developed REAL TIME WEATHER REPORT STREAMING WITH GRAPHS USING IOT proto type

The developed IoT-based real-time weather monitoring system was successfully implemented and tested under various environmental conditions, demonstrating reliable performance in data acquisition, transmission, and visualization. The system effectively captured parameters such as temperature, humidity, and atmospheric pressure using connected sensors and transmitted the data to the cloud platform without significant delay. The recorded data was continuously updated and displayed in the form of real-time graphs, enabling clear visualization of environmental variations over time. The graphical interface showed smooth and consistent trends, confirming accurate sensor readings and stable network communication. Additionally, the system allowed remote monitoring through a web/mobile dashboard, ensuring accessibility from any location. The overall performance indicated low latency, high efficiency, and good scalability, making the system suitable for applications such as smart agriculture and environmental monitoring. The results validate that the proposed system provides an effective, low-cost solution for real-time weather data streaming and graphical analysis using IoT technology.

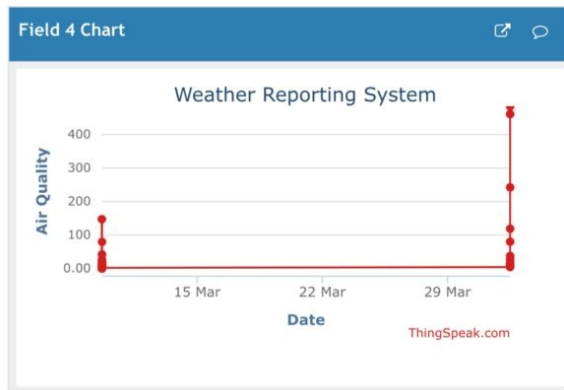

FIGURE 3: Air Quality Graph

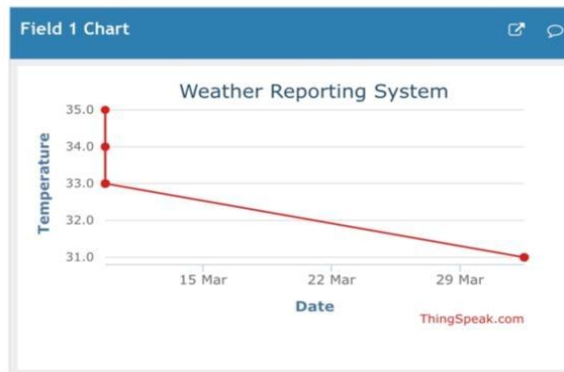

FIGURE 4: Temperature Graph

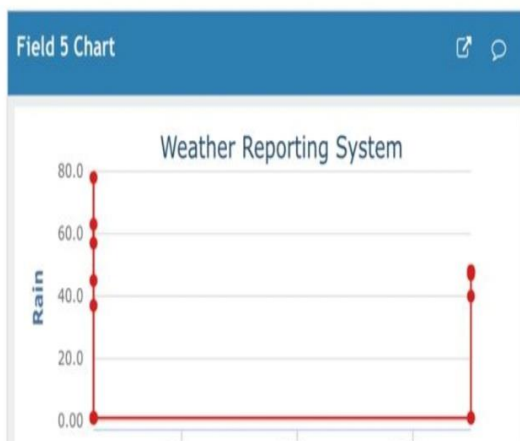

FIGURE 5: Rain Graph

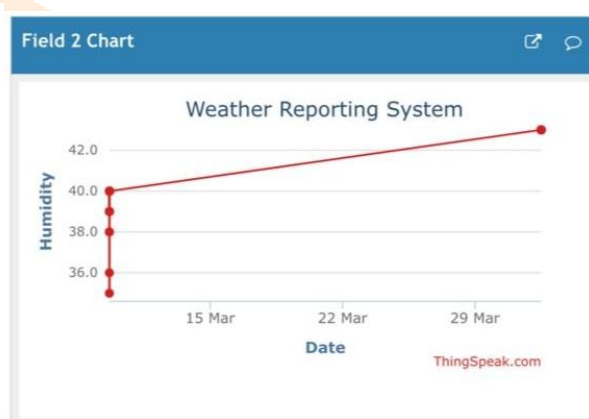

FIGURE 6: Humidity Graph

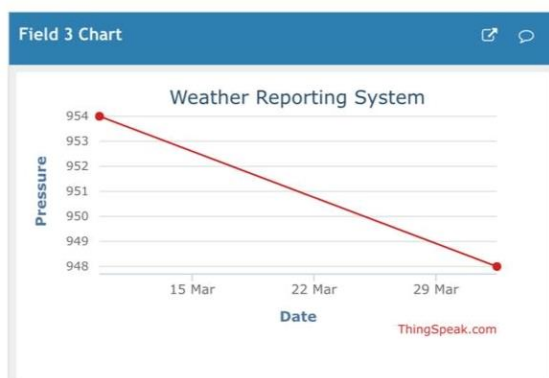

FIGURE 7: Pressure Graph

4.1 PREFORAMANCE AND ANALYSIS

The performance of the proposed IoT-based real-time weather monitoring system was evaluated based on parameters such as accuracy, latency, reliability, and scalability. The sensor readings for temperature, humidity, and pressure were observed to be consistent with standard environmental conditions, with minimal deviation, indicating acceptable accuracy for practical applications. The system demonstrated

low latency in data transmission, as updates were reflected on the cloud dashboard and graphical interface within a few seconds, ensuring near real-time monitoring. Network stability played a crucial role in maintaining continuous data flow, and the system performed efficiently under stable Wi-Fi conditions with negligible data loss. The graphical analysis of collected data showed smooth temporal variations, enabling easy identification of trends and anomalies. Furthermore, the system proved to be scalable, as additional sensors can be integrated without significant modification to the existing architecture. Power consumption was also optimized due to the use of energy-efficient microcontrollers like ESP8266/ESP32. Overall, the analysis confirms that the system is reliable, cost-effective, and suitable for long-term environmental monitoring applications, although performance may be affected under poor network conditions or extreme environmental factors affecting sensor precision.

5.CONCLUSION

The proposed “Real-Time Weather Report Streaming with Graphs Using IoT” system successfully demonstrates how IoT technology can be utilized to monitor and analyze environmental conditions in real time. By integrating sensors such as temperature, humidity, soil moisture, and NPK sensors with a NodeMCU microcontroller, the system is capable of continuously collecting field data and transmitting it to a cloud platform through Wi-Fi connectivity.

The use of cloud-based IoT platforms such as ThingSpeak or Blynk enables efficient storage, processing, and graphical representation of sensor readings. The graphical visualization of data helps users easily understand changes in environmental conditions and identify trends over time. This makes the system highly useful for smart agriculture, where timely information regarding soil and weather conditions can improve irrigation planning, nutrient management, and crop productivity.

Compared with traditional weather monitoring methods, the proposed system offers several advantages such as remote accessibility, low cost, real-time operation, and ease of deployment. The incorporation of multiple sensors in a single platform increases the overall effectiveness and accuracy of the system.

Although the current system depends on stable internet connectivity and proper sensor calibration, it provides a strong foundation for future developments. In the future, the system can be enhanced with artificial intelligence, automated irrigation control, and predictive analytics to make farming more efficient and sustainable.

6.REFERENCE

- [1] D. Singh, G. Tripathi, and A. J. Jara, “A survey of Internet-of-Things: Future vision, architecture, challenges and services,” *IEEE World Forum on Internet of Things (WF-IoT)*, pp. 287–292, 2014.
- [2] K. Ashton, “That ‘Internet of Things’ Thing,” *RFID Journal*, 2009.
- [3] A. Banks and R. Gupta, “MQTT Version 3.1.1,” *OASIS Standard*, 2014.
- [4] M. Collotta and G. Pau, “A novel energy management approach for smart homes using Bluetooth Low Energy,” *IEEE Journal on Selected Areas in Communications*, vol. 33, no. 12, pp. 2988–2996, 2015.
- [5] O. Vermesan and P. Friess, *Internet of Things: Converging Technologies for Smart Environments and Integrated Ecosystems*. Aalborg, Denmark: River Publishers, 2013.
- [6] S. Madakam, R. Ramaswamy, and S. Tripathi, “Internet of Things (IoT): A literature review,” *Journal of Computer and Communications*, vol. 3, no. 5, pp. 164–173, 2015.
- [7] A. Kumar, I. P. Singh, and S. K. Sud, “Energy efficient wireless sensor network design and implementation for condition monitoring,” *International Journal of Computer Applications*, vol. 65, no. 12, pp. 1–6, 2013.
- [8] B. A. Adebisi et al., “IoT-based real-time weather monitoring system,” *IEEE Sensors Journal*, vol. 19, no. 12, pp. 1–8, 2019.