



ENHANCING SMART GRIDS WITH A NEW IOT AND CLOUD-BASED SMART METER TO PREDICT THE ENERGY CONSUMPTION WITH TIME SERIES

Dr.T NARASIMHA PRASAD,M.Tech,P.hd (Associate Professor)

Mallavarapu Lakshmanudu, Inagala Vinay, Mallavarapu Manikanta, Pagolu Uma Naga Bala

Koteswara Rao

**ST.ANN'S COLLEGE OF ENGINEERING & TECHNOLOGY CHIRALA
(AUTONOMOUS)**

DEPARTMENT OF ELECTRICAL & ELECTRONICS ENGINEERING

ABSTRACT

The increasing demand for electricity, driven by the proliferation of energy-consuming devices and growing production facilities globally, poses challenges to maintaining a balanced energy grid and managing energy prices. To address these issues, this study introduces a transformative solution by developing an Internet of Things (IoT)-based Smart Meter (SM) for integration into Smart Grid (SG) infrastructures. The proposed SM offers advanced capabilities, including high data rates, bidirectional data transmission, and real-time energy consumption tracking, empowering consumers with valuable insights into their energy usage patterns. In the proposed system user can also control the loads along with industrial load monitoring from remote mobile application.

I. INTRODUCTION

The modern era is characterized by an ever-growing demand for electricity, driven by the widespread adoption of energy-consuming devices and the expansion of industrial facilities on a global scale. This surge in electricity consumption presents significant challenges for maintaining a balanced energy grid and effectively managing energy prices. Traditional electricity meters, often limited in functionality and capabilities, struggle to provide consumers with meaningful insights into their energy usage patterns in real-time, hindering efforts to optimize energy consumption and reduce costs.

To address these challenges, this study introduces a transformative solution by proposing the development and integration of an Internet of Things (IoT)-based Smart Meter (SM) into existing Smart Grid (SG) infrastructures. The proposed SM is designed to offer advanced functionalities, including high data rates, bidirectional data transmission, and real-time energy consumption tracking, thereby empowering consumers with valuable insights into their energy usage. Additionally, the proposed system enables users to remotely

control loads and monitor industrial loads through a dedicated mobile application, further enhancing efficiency and convenience in energy management.

The integration of IoT-based Smart Meters into Smart Grid infrastructures represents a paradigm shift in the way energy is monitored, managed, and consumed. By leveraging the capabilities of IoT technology, the proposed system not only addresses the limitations of traditional electricity meters but also opens up new possibilities for grid optimization, demand-side management, and sustainable energy practices.

In this study, we aim to explore the development and implementation of IoT-based Smart Meters as a key enabler of smart energy ecosystems. Through a combination of advanced hardware, software, and mobile applications, the proposed system seeks to revolutionize energy management at both the consumer and grid levels, driving positive outcomes for energy efficiency, grid stability, and user experience. Through rigorous testing and evaluation, we aim to demonstrate the feasibility and effectiveness of the proposed system in real-world scenarios, paving the way for its widespread adoption and integration into future energy infrastructures.

II. EXISTING METHODS AND DRAWBACKS

Traditional Electricity Meters:

Method: Traditional electricity meters measure energy consumption through mechanical or electromechanical mechanisms. They provide basic information on energy usage but lack advanced functionalities such as real-time monitoring and bidirectional data transmission.

Drawbacks: Traditional meters offer limited visibility into energy usage patterns, making it challenging for consumers to optimize their energy consumption. Additionally, they do not support bidirectional data transmission, hindering grid management and demand-side management efforts.

Automated Meter Reading (AMR) Systems:

Method: AMR systems utilize automated meter reading technologies, such as radio frequency (RF) or power line communication (PLC), to remotely collect energy consumption data from meters. These systems offer improved data collection efficiency compared to manual meter reading methods.

Drawbacks: While AMR systems enhance data collection efficiency, they often lack advanced features such as real-time monitoring and remote control capabilities. Additionally, they may require infrastructure upgrades and investments in communication networks.

Advanced Metering Infrastructure (AMI):

Method: AMI systems integrate advanced metering technologies, communication networks, and data management systems to enable real-time monitoring, bidirectional data transmission, and remote control capabilities. These systems offer comprehensive insights into energy usage patterns and support grid management functionalities.

Drawbacks: AMI systems require significant investments in infrastructure and deployment costs. Additionally, they may face challenges related to data privacy, security, and interoperability with existing grid infrastructure.

Home Energy Management Systems (HEMS):

Method: HEMS integrate smart devices, sensors, and energy management software to enable consumers to monitor and control their energy usage in real-time. These systems often include features such as energy consumption dashboards, smart thermostats, and appliance control functionalities.

Drawbacks: While HEMS offer granular insights into energy usage patterns and support remote control capabilities, they may not always integrate seamlessly with existing grid infrastructure. Additionally, adoption rates may vary due to cost considerations and perceived complexity.

Manual Load Control Systems:

Method: Manual load control systems rely on user intervention to adjust energy consumption based on real-time data or utility signals. These systems may involve turning off non-essential appliances during peak demand periods or implementing time-of-use pricing schemes.

Drawbacks: Manual load control systems require active user participation and may not always be practical or effective in optimizing energy consumption. Additionally, they may lack automation and scalability compared to automated solutions.

In summary, while existing methods such as traditional electricity meters, AMR systems, and HEMS offer various benefits, they also have notable drawbacks, including limited visibility, scalability, and interoperability. Addressing these limitations requires the development and integration of advanced smart metering solutions, such as IoT-based Smart Meters, which offer real-time monitoring, bidirectional data transmission, and remote control capabilities to empower consumers and grid operators alike.

III. EXPECTED RESULTS: The expected results of implementing the IoT-Based Smart Meter concept are multifaceted and aimed at addressing key objectives of the study. Here are the anticipated outcomes:

- **Real-Time Energy Monitoring:** □ **Result:** Users can successfully monitor their energy consumption in real-time through the 16x2 LCD display and the mobile application. □ **Outcome:** Enhanced awareness and understanding of current energy usage patterns, empowering users to make informed decisions for energy conservation.
- **Remote Load Control and Overload protection:** □ **Result:** The relays, controlled by the Arduino Uno and Wi-Fi module, effectively enable users to remotely control connected loads through the mobile application. □ **Outcome:** Improved flexibility and convenience for users in managing and optimizing their energy consumption preferences.
- **Cost Monitoring and Alerts:** □ **Result:** The PZEM-400T and Arduino Uno accurately measure energy consumption, allowing for real-time calculation of costs displayed on the 16x2 LCD. The buzzer issues alerts for power outages or abnormal consumption patterns, Like Different patterns of beeps or tones could signify various abnormal conditions, such as voltage fluctuations, overloads, or system faults. For

example: **Outcome:** Users receive timely alerts and have a clear understanding of their energy costs, facilitating proactive measures and optimized energy spending.

Block diagram:

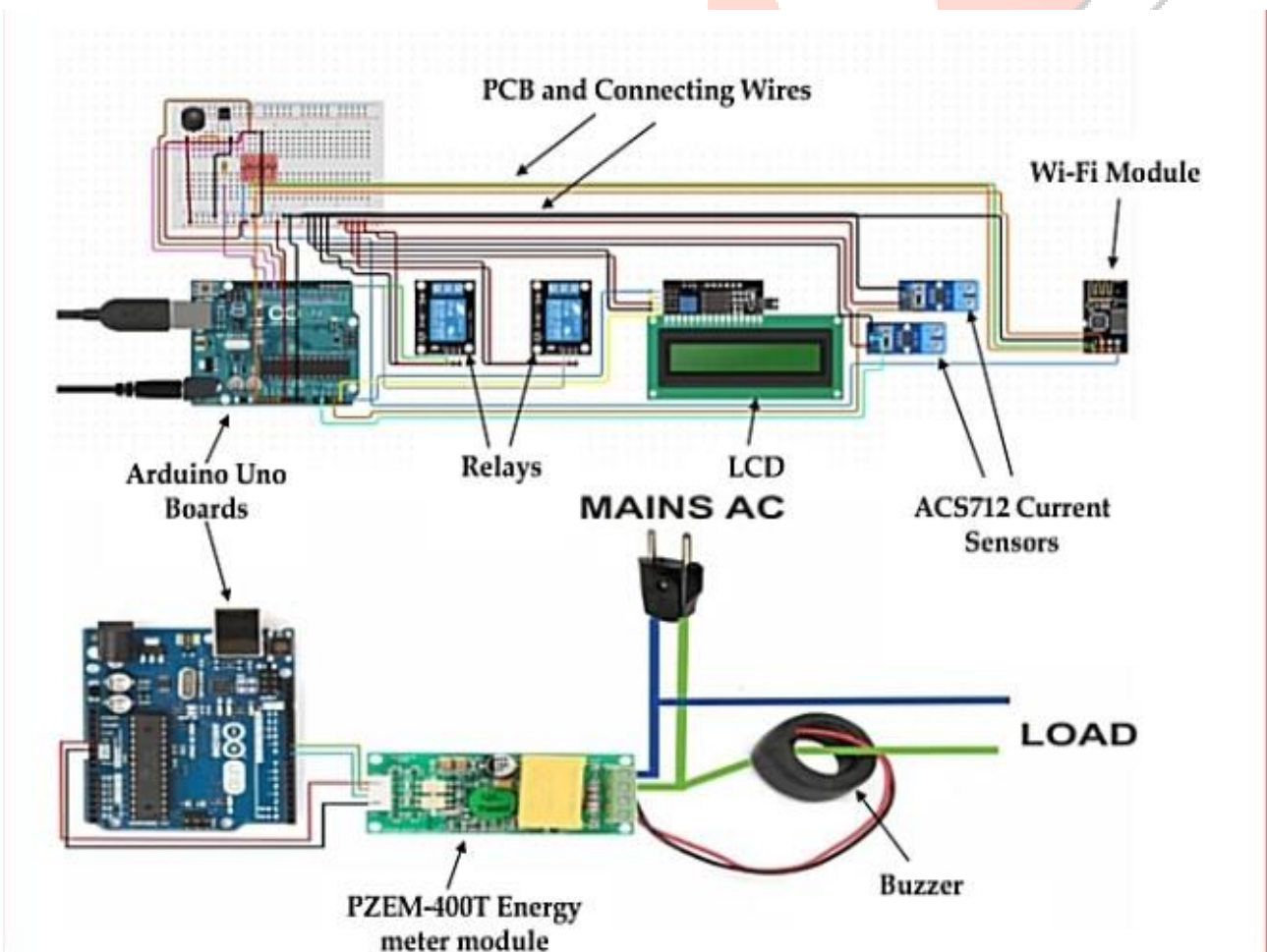
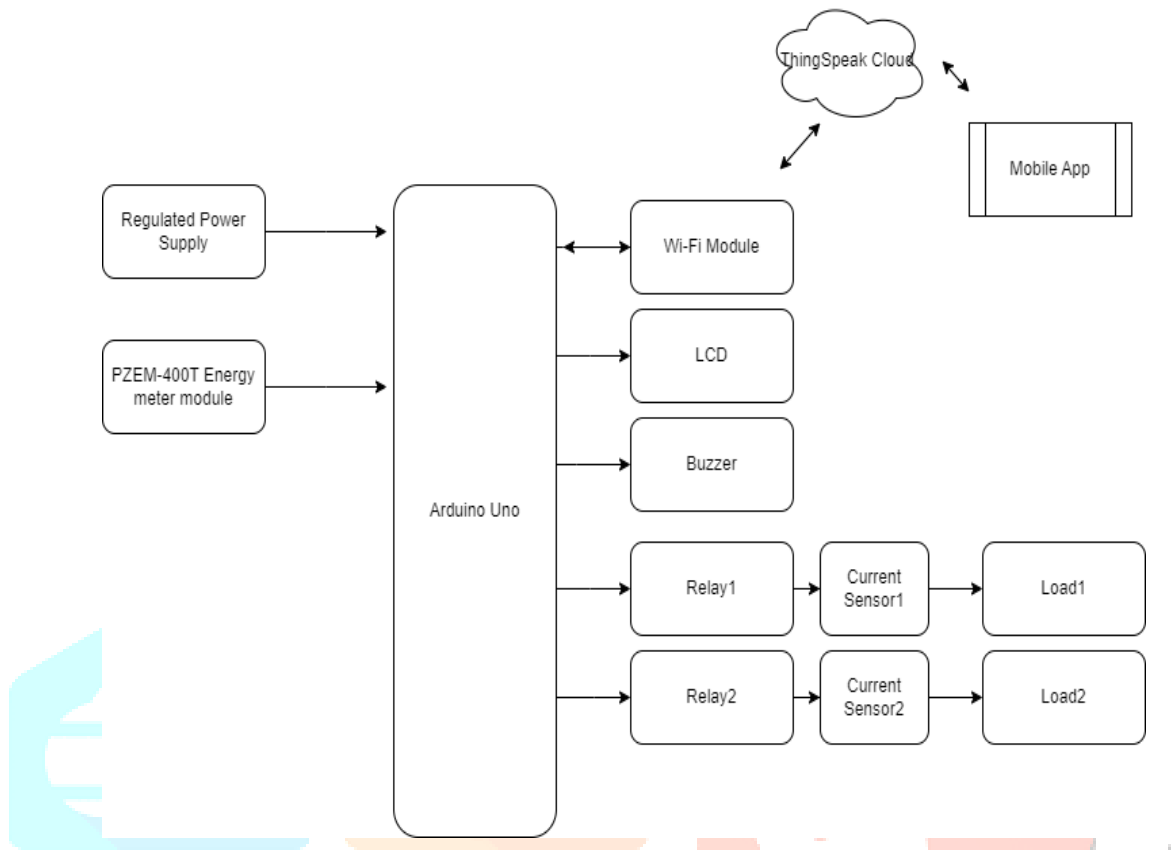

CIRCUIT DIAGRAM

ThingSpeak IoT Platform

ThingSpeak is IoT platform for user to gather real-time data; for instance, climate information, location data and other device data. In different channels in ThingSpeak, you can summarize information and visualize data online in charts and analyze useful information.

ThingSpeak can integrate IoT:bit (micro:bit) and other software/ hardware platforms. Through IoT:bit, you can upload sensors data to ThingSpeak (e.g. temperature, humidity, light intensity, noise, motion, raindrop, distance and other device information).

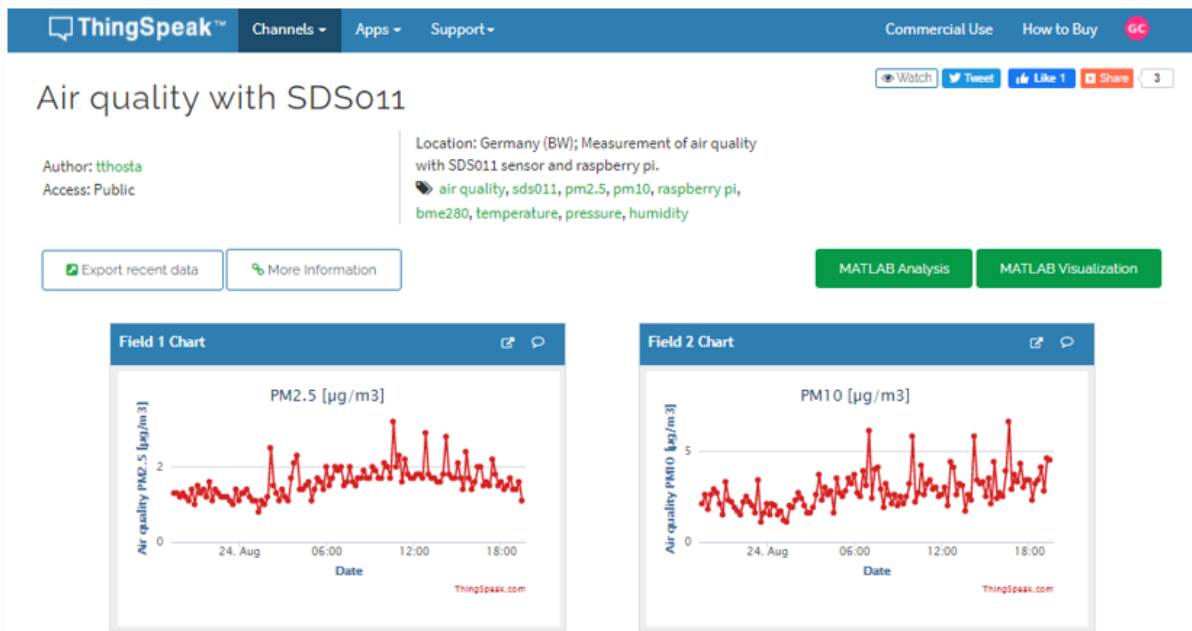

5.1. Thingspeak Configuration

Goal:

we need to create the thingspeak channel and get the key

Step 1

Go to <https://thingspeak.com/>, register an account and login to the platform

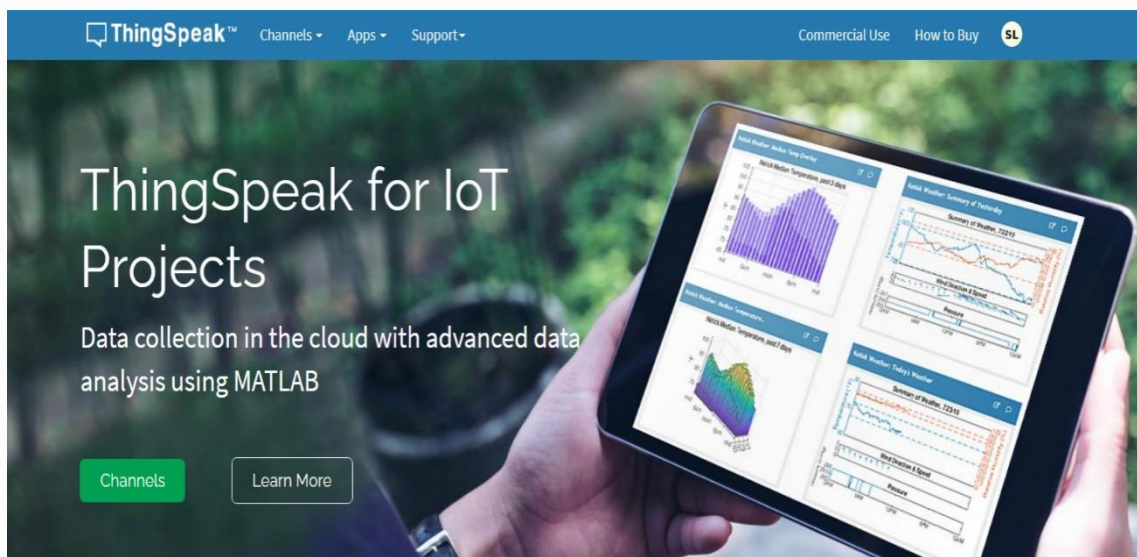

Step 2

Choose Channels -> My Channels -> New Channel

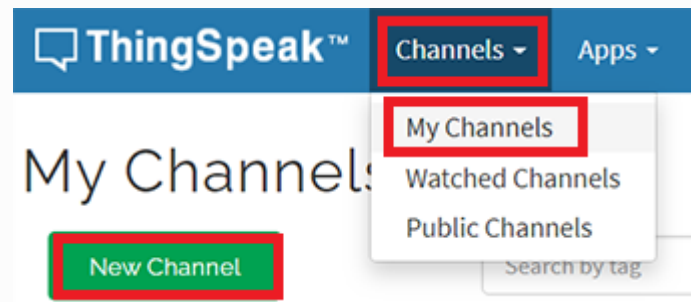

Step 3

Input Channel name, Field1 , then click “Save Channel”

- Channel name: smart-house
- Field 1: Temperature

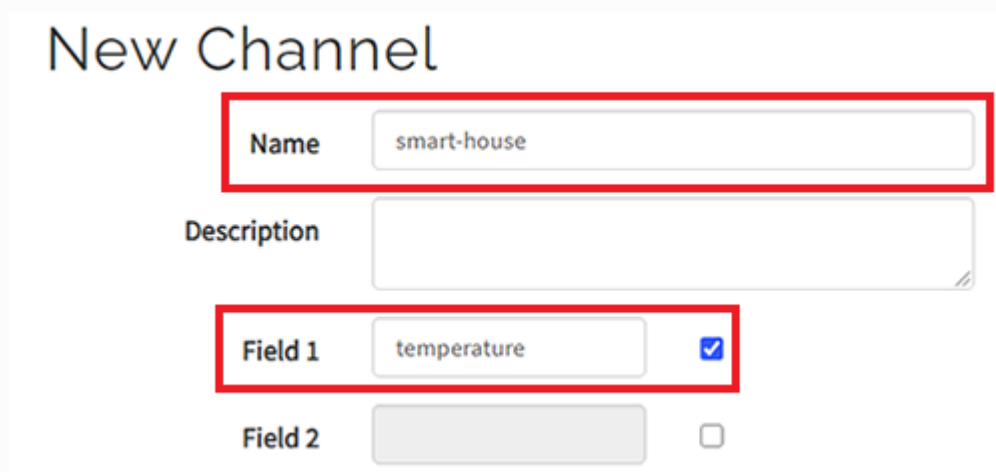

Step 4

You will see a chat for data field1



Step 5

Open your web browser, go to <https://thingspeak.com>, select your channel > “API Keys”, copy the API key as follows:

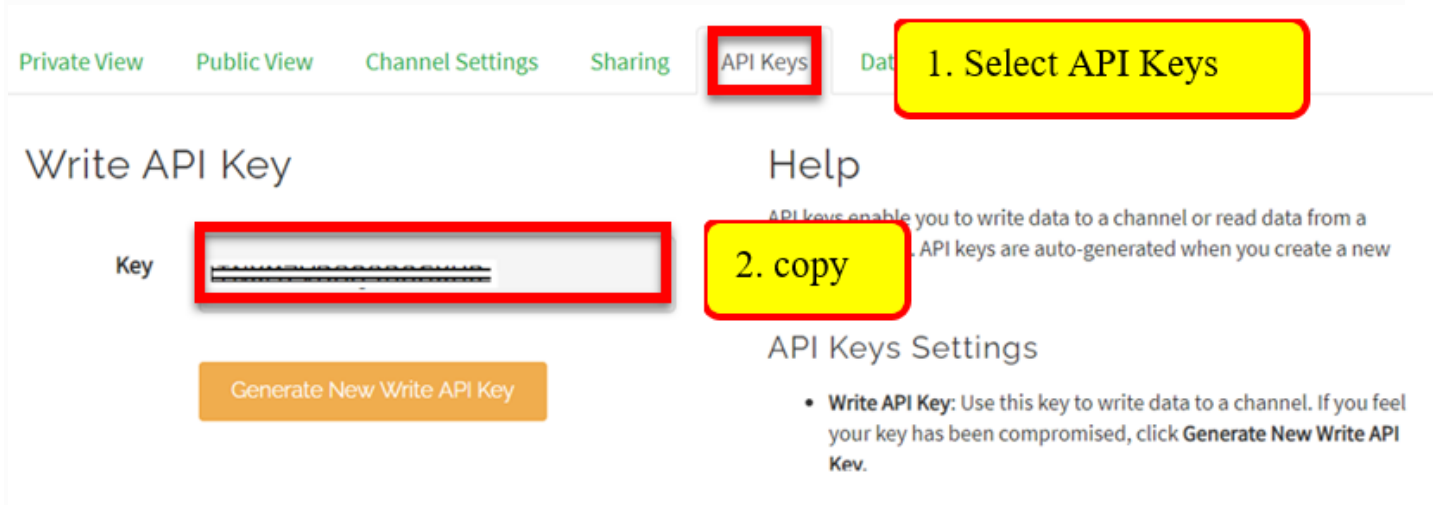

EXPECTED RESULTS

○ The expected results of implementing the IoT-Based Smart Meter concept are multifaceted and aimed at addressing key

objectives of the study. Here are the anticipated outcomes:

□ **Real-Time Energy Monitoring:**

□ **Result:** Users can successfully monitor their energy consumption in real-time through the 16x2 LCD display and the mobile application.

□ **Outcome:** Enhanced awareness and understanding of current energy usage patterns, empowering users to make informed decisions for energy conservation.

□ **Remote Load Control and Overload protection:**

□ **Result:** The relays, controlled by the Arduino Uno and Wi-Fi module, effectively enable users to remotely control connected loads through the mobile application.

□ **Outcome:** Improved flexibility and convenience for users in managing and optimizing their energy consumption preferences.

□ **Cost Monitoring and Alerts:**

□ **Result:** The PZEM-400T and Arduino Uno accurately measure energy consumption, allowing for real-time calculation of costs displayed on the 16x2 LCD. The buzzer issues alerts for power outages or abnormal consumption patterns, Like Different patterns of beeps or tones could signify various abnormal conditions, such as voltage fluctuations, overloads, or system faults.

▪ Intermittent beeping could indicate a voltage fluctuation For example: ▪ Rapid beeping could signal an overload condition.

▪ A combination of long and short beeps could indicate a system fault.

□ **Outcome:** Users receive timely alerts and have a clear understanding of their energy costs, facilitating proactive measures and optimized energy spending

Mobile Application :

A mobile application can be developed to provide consumers with real-time insights into their energy consumption. The app can display usage trends, provide tips for energy conservation, and offer personalized recommendations to help users reduce their energy bills.

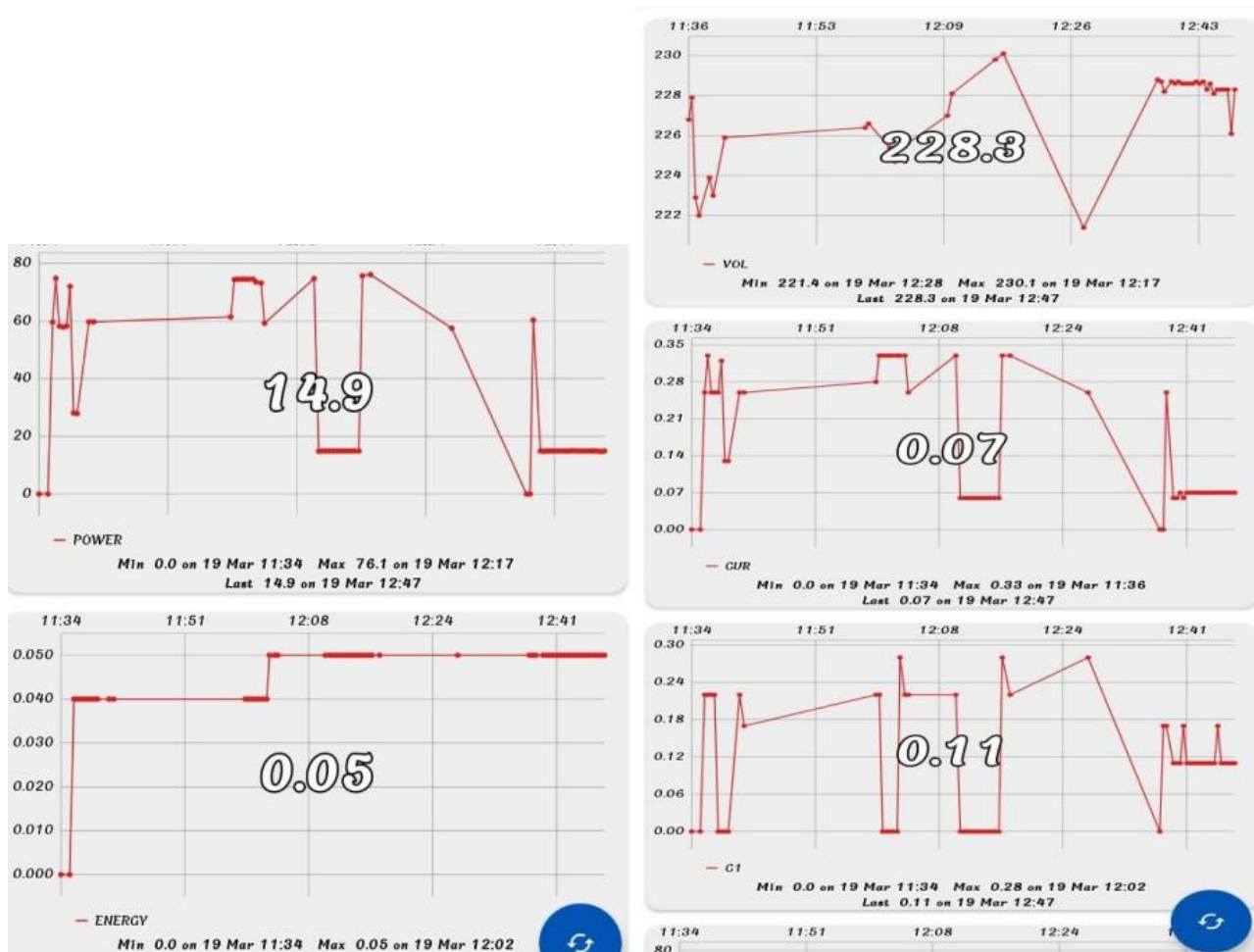

IV. CONCLUSION

In conclusion, the proposed IoT-based energy monitoring and control system represents a significant advancement in energy management technology, offering real-time monitoring, remote control capabilities, and overload protection functionalities. Through the integration of Arduino microcontroller boards, energy meter modules, IoT connectivity, and a user-friendly mobile application, the system empowers users to optimize their energy usage, enhance grid stability, and promote sustainability.

By providing real-time insights into energy consumption patterns and enabling remote load control, the system facilitates energy efficiency practices, leading to reduced energy waste and lower utility bills for consumers. Additionally, the integration of overload protection features ensures equipment safety and prevents damage caused by excessive energy consumption.

The versatility of the system makes it applicable across various sectors, including residential, commercial, industrial, and smart city environments. Whether it's monitoring household energy usage, optimizing industrial processes, or contributing to smart grid initiatives, the system offers valuable capabilities for enhancing energy management practices and supporting the integration of renewable energy sources.

Furthermore, the system contributes to grid stability and reliability by enabling demand-side management, load balancing, and integration of renewable energy sources. This is particularly crucial in the context of increasing energy demand and the transition towards a more sustainable energy future.

In conclusion, the IoT-based energy monitoring and control system offers a comprehensive solution for addressing the challenges of energy management, empowering users with actionable insights and control over their energy usage. Through continued innovation, deployment, and integration, this system has the potential to drive positive outcomes for energy efficiency, grid stability, and sustainability, paving the way for a smarter, more resilient energy ecosystem.

V. REFERENCES:

- [1] H. Gharavi, R. Ghafurian, Smart Grid: The Electric Energy System of the Future, IEEE Proceedings, Piscataway, NJ, USA, Vol. 99, 2011, pp. 917–921.
- [2] H. Garg, M. Dave, Securing iot devices and securely connecting the dots using rest api and middleware, in: 4th Int. Conference on Internet of Things: Smart Innovation and Usages(IoT-SIU),2019,pp.1–6.
- [3] R. Obringer, R. Nateghi, What makes a city ‘smart’ in the Anthropocene? A critical review of smart cities under climate change, Sustain. Cities Soc. 75 (2021), 103278.
- [4] S. Ali, S. Gosavi, A. Ahmed, S. Khan, A. Kapse, M. Nasiruddin, IoT based smart fuel meter: a review, J. Dig. Integr. Circuits Electrical Dev.(2022)1–5.
- [5] V. Slany, P. Koudelka, E. Krcalova, J. Jobbagy, L. Danys, R. Jaros, R. Martinek, New hybrid IoT