



DESIGN AND FABRICATION OF A GROUNDNUT OIL EXPELLING MACHINE

Dr. Bitla Venu^[1], Jakku Sathwik ^[2]

Head of Mechanical Engineering Department, Department of Technical Education –
Telangana State ^[1],

Student of Govt. Polytechnic, Parkal, Warangal, Telangana State-506164, India

ABSTRACT: A misconception exist between groundnut oil and other vegetable oil used in Nigeria because of the inefficient processes of producing groundnut oil in commercial quantity. This work, design and fabrication of an automated groundnut oil extractor was aimed to produce pure groundnut oil which would be better than the common vegetable oil (refined, bleached and deodorized palm oil) due to its natural process of extraction this machine this machine designed to the power a by 075kw electric motor with 1400 rpm and 50Hz single phase. The desired crushing effect at low power input would be achieved by the incorporation of a gear reduction system of 1:10. The procedures employed include the design stage, construction and testing. The machine components are: the electric motor, expellant unit, drains collector, belt, driving and driven pulleys, and the hopper. The expelling unit consists of a screw expellant shaft with expellant barrel. The maximum crushing stress of the groundnut was determined experimentally as 23.1KN/m^2 . A heater of 1500W was used to preheat the groundnut before crushing. The groundnut was heated for 15mins which resulted to the production of 0.23kg quantity of oil with improved quality. When heated for 10mins the quantity produced was 0.019kg which contained some impurities. The result showed that at 15mins preheating of the groundnut the quantity and quality of oil produced were better than the one produced when heated for 10mins. Therefore, the rate of oil extraction was effective and efficient at 15mins heating time. At a regulated heater temperature of 100°C the quality of the oil and groundnut cake was pleasant and edible. Based on the efficiency and the quality of the oil produced, this machine was recommended suitable for the production of groundnut oil for commercial use.

KEY WORD: Extraction, Crushing stress, weldability, Expeller, forgeability

I. INTRODUCTION

Groundnut oil expelling machine is an important device for oil recovery from groundnut seed in a roller mill, direct firing of barrel and pressing with an engine driven oil expeller. Expeller use a horizontal rotating metal screw, which feeds oil-bearing seeds into a barrel shaped outer casing with perforated walls according to Maul et al (2011). The seeds are continuously fed to the expeller, which grinds, crushes and presses the oil out as it passes through the machine (Khangar and Jaju 2012). The pressure ruptures the oil cells in the product and oil flows through the perforation in the casing and passes through the oil outlet and is finally collected with oil receiving container underneath. The residue of the material from which oil has been extracted, are sent out through the cake outlet.

Expeller are power driven, and are able to process 8 to 300kg of groundnut per hour or even more depending upon the type of expeller used (Khangar and Jaju, 2012). Bigger units which process greater quantities of oil are available for use in larger mills. The percentage of oil extracted by expellers is nearly 90% depending upon the type and kind of products as well as the expeller being employed. The friction created by the products being pressed wears down the worm shaft and other internal parts, and also have the tendency of creating problem or causes failure of main shaft.

The need to produce a groundnut oil expelling machine arose even in the distant past due to the need to produce oil for domestic and commercial uses. According to history, one of the major forces driving scholars into research is the desire to produce machineries that will be used for the production of food for man and animal. (Bachman, 2001)

According to Saeed, 1991, the Chinese was the first people to expel oil from seeds. The first man grains or nuts in a hollow of a natural stone, he pounded it with a stone and expels the oil used for cooking and other purposes. Because the process of physical change occurring in each grain or nut was complex and numerous nuts were simultaneously processed, he could not regulate them directly. His work was only a simple mechanical action repeated monotonously.

According to Miwa (1990), kohlus and small expellers were used solely at village level technologies. Statement of Problem

Groundnut oil expeller has been developed and constructed by some researchers in different sizes, shapes and materials, mostly for industrial uses. Such expellers are expensive, involve high level technology which cannot be afforded by small scale and low income oil millers. In order to assist the small scale oil millers in the local communities, small scale groundnut oil expellers need to be designed, and constructed with locally sourced materials.

Objective of the Study

The main objective is to design and fabricate of an improved, durable groundnut oil expeller, using local sourced materials.

Other specific objectives are:

- To develop a machine that can extract oil from groundnut, within a minimum time frame.
- To design, develop and test expeller that is affordable to small scale oil millers.

Modern Methods of Groundnut Crushing and Oil Extraction

Saeed (1991), with the exit from the windless press and water mills, the first mechanical screw press was successfully used in 1906. The manufacturers had come a long way since then with improved materials of construction, manufacturing methods, research and development, thus increasing the efficiency of the screw press. As a result, various types of improved expellers were developed to meet the requirement of the processors.

Shafiq (1991), made a comparison between the improved expeller and a standard expeller and revealed that optimal operation of the expeller was not achieved. Shafiq (1991), noted that;

- a. The driving mechanism needed improvement as the small worm gets frequently break into pieces.
- b. Energy consumption of the modified expeller was higher when compared to the standard improved expeller.
- c. In the absence of any producing standard specification the manufacturing were producing substandard expellers.

II. DESIGN METHODOLOGY AND ANALYSIS

For an intelligent and resourceful design, the designer must clearly know the material which are available and the properties they possess. Selection of material depends on many features such as the intensity and type of stress to which the components are subjected to, whether it is flexible or rigid or it is to experience high temperature or corrosive action and how it leads itself to processes of manufacture, i.e. forging, machine etc. Therefore the designer's selection will influence the following factors:

- 1.Strength
- 2.Weight
- 3.Appearance
- 4.Manufacture
- 5.Cost of production

These will also determine the variation between success and failure of the machine. We can further classify the above factor into four main classes:

- a.Service Requirements
- b.Construction Requirement
- c.Economic Requirement
- d.Maintenance Requirement

Service Requirements

Before a material is chosen for construction, it must possess some distinct properties which it exhibits when put to play. These properties are generally referred to as the service requirement. Some these properties which should be appreciable while the material is in service are:

- a. Strength
 - b. Toughness
 - c. Hardness
 - d. Stiffness
- a. Resistance to corrosion
 - b. Conductivity and heat resistance.

Fabrication Requirement

For fabrication process, a material must possess some distinct properties, these are mainly forge-ability, malleability, ductility and weldability. Materials undergoing forgeability are heated to a temperature close to its melting point then shaped to desired structure. For malleability, it's required that the material should be made into a sheet like form while ductility requires the material to be drawn into a wire form. Finally, weldability which is the ability for the material to be welded. Therefore the materials must be able to be joined by the process of welding.

Economic Requirement

This is about the most important factor for the material selection because it determines the total cost of production which in turn affects the price of the product or retail cost and consumer choice. If the total cost of production is high, variably the price of the finished product will also be high. When the price of a product is high, consumers will seek for alternative cheap but similar goods. Bearing in mind that the two aims of production is satisfying consumer wants and needs and also to make maximum profit. As a producer one must judiciously select relatively cheap but reliable and appropriate materials for production. This will reduce the overhead cost of production therefor making it cheap in respect to other similar materials. Then we can comfortably harmonize the cost of production with the real price. One of the major consideration in engineering design is to design machines that are reliable, cost effective and the ability of the machine solving human problem. This was one of our consideration in this project work.

II. MATERIALS USED FOR THE FABRICATION

A list of the material selected for the major components of the design is shown in table 1.0 below. The table also shows the values of the useful properties of the material used.

Table 1.0: list of Materials used for the Fabrication

COMPONENTS	MATERIAL SELECTION	SELECTION CRITERIA	VALUE OF USEFUL PROPERTY
Expeller Screw	Medium carbon steel	Conventional and stronger than mild steel and its locally available	Yield strength: Sy = 248MN/M ² Tensile strength: Su=399MN/M ²
Pressure cone	Medium carbon case hardened steel	Hard water resistance material and it is locally available	Yield strength: Sy = 289MN/M ² Tensile strength: Su=413MN/M ²
Bearing supporting bar	Mild Steel	Easily machined	Yield strength: Sy = 230MN/M ² Tensile strength: Su=205MN/M ²

Hopper	Mild steel plate	Easily machined	Yield strength: Sy = 230MN/M ² Tensile strength: Su=205MN/M ²
Speed reduction system	Electric motor, belt and pulley	Single phase electric motor of 1hp	Good serviceability and relatively cheap to maintain
Angle iron	Mild steel	Locally available	Yield strength: Sy = 230MN/M ² Tensile strength: Su=205MN/M ²

Design Approach

In order to achieve the design objective an experiment was performed to determine the crushing force of one groundnut.

Experiment: Determining of the strength and torque required to crush one groundnut at different temperatures. **Fundamental:** In the design of any crushing machine it is fundamental to determine the torque hence power requirement, for economics and optimal performance, the output shaft in a typical groundnut crusher performs both crushing and transportations. The determination of the crushing strength is based on the principle of compression of the nut between two parallel plates and to obtain the crushing force, a screw mechanism is utilized. This can be simulated simply as crushing strength, $\sigma = \frac{F}{A}$ where, F is a force applied by screw and A is the area.

Torque applied by the screw is obtained from a standard equation, $F = FL$ where, F is the applied force and L is the distance between the point of application and axis of the screw. (Khurmi and Gupta, 1998)

Apparatus: Electronic weighing balance, flakes of cotton wool liquid in glass thermometer, torsion bar, measuring, cylinder, lathe tool post, two perforated mild steel plates of thickness 2mm and steel container see figure 1 below:

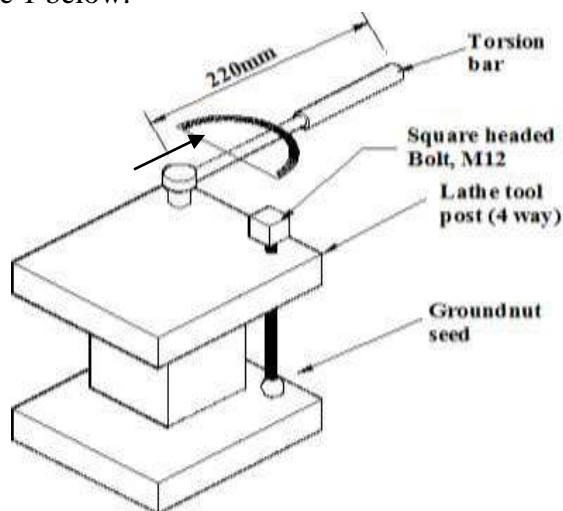

Fig. 1.0 A system of Lathe tool (Experimental setup)

Procedure:

The masses of 15 different groundnut were measured and recorded using the electronic weighing balance.

1. The volumes of the groundnut were obtained using the measuring cylinder.
2. An ambient temperature of 28°C was assumed. The experiment set up is shown in fig 1.0. The nut sandwiched on top and bottom by cotton wool flakes on the other side of each cotton wool flakes. The set- up was then placed between pressure plates. The function of the cotton wool flakes is to absorb the oil expelled upon pressure application. These perforated mil steel plates allow the expelled oil to drain through as the pressure was applied to the plate by the screw rotation by a torsion bar.
3. Force was applied at intervals and the corresponding values of oil were estimated. Force application stopped when negligible increase in volume was observed.
4. The reading of the gauge was recorded.
5. The masses of both pairs of cotton wool were reweighed after each experiment. Let: M_c = Mass of oil recorded

M_a = Mass of cotton wool flakes after experiment. M_b = Mass of cotton wool flakes before experiment.

Therefore, $M_c = M_a - M_b$

All masses were measured using the weighing balance the torque values were read in round feet. $1\text{pdft} = 0.04210\text{N/M}$

Density of crude groundnut = 0.91g/cm^3 .

Volume of oil after each experiment were calculated as:

$V = \frac{M_c}{\rho}$ where: M

= mass of oil extracted, ρ = density of crude groundnut

The result is summarize in tabular form as shown in table 1.1 below:

From fig 1.1 the distance between the point of force application and axis of the screw, $L = 220\text{mm} = 0.22\text{m}$

Table 1.1: Summary of the Result

S/N	Average torque (N/M)	- Force $\frac{1}{L} =$ (N)
1	2.100	9.545
2	2.158	9.809
3	2.160	9.818
4	2.109	9.586
5	2.225	10.114

In order to determine the crushing stress δ , the area of spread was taken into account, Fig 1.1 shows the groundnut spread after crushing which approximates to a circle.

$V = \frac{1}{2} \pi 1002200 - 392126 = 1.571\ 2000000 - 191646 = 2840924.134 \times 10^{-9} = 0.003\text{m}^3$ ans.

3.2.2 Cylindrical Barrel or Extracting Chamber Design

The extracting chamber is design based on internal pressure in the chamber, the extracting chamber is treated as thin walled cylinder or vessel as given by Khurmi and Gupta (2004), the tangential stress perpendicular to the axis of the cylinder

$\sigma = \rho d / 2t$ Mpa 2

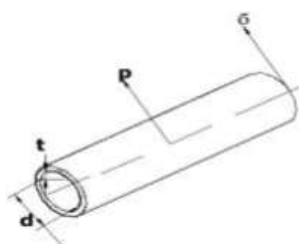

Fig 1.3: Cylindrical barrel

Where:

σ = perpendicular or hoop stress, d = internal diameter (50mm), t = thickness (5mm), ρ = internal pressure = force/area of cylinder = F/A .

Where:

area of a cylinder, $A = \pi R^2 = 3.142 \times 25^2 = 1963.75 \text{ m}^2 \text{ ans.}$

force, $F = \text{Torque, } T / \text{length of the chamber, } l \dots \dots \dots 3$

Where:

Length of the chamber, $l = 398 \text{ mm}$

Torque, $T = \text{HP } 5252 / N \dots \dots \dots 4$

Where:

HP = horse power (1), N = shaft speed (1400rpm)

$\therefore T = 5252 / 1400 = 3.75 \text{ (NM) ans}$

$\therefore F = T / l = 3.75 / 398 = 0.0094 \text{ (N) ans}$

$\therefore \rho = F / A = 0.0094 / 1963.75 = 4.8 \times 10^{-6} \text{ ans}$

$\therefore \zeta = \rho d / 2t = 4.8 \times 10^{-6} \times 50 / 2 \times 5 = 2.4 \times 10^{-5} \text{ Mpa}$

3.2.3 Power Required for Crushing

The power required for crushing is determined from the equation 5 as given by Khumi and Gupta (2004).

$pe = 2\pi NT / 60 \dots \dots \dots 5$

Where:

pe = power required in watt (750w = 0.75kw) T = torque = ?

If average N = Shaft speed = 60rpm $\pi = 3.142$

from the equation 5 above

$T = pe60 / 2\pi N = (750 \times 60) / (2 \times 3.142 \times 60) = 45000 / 377.04 = 119.4 \text{ NM ans.}$

The power required for crushing is given by

$\therefore pe = (2 \times 3.142 \times 60 \times 119.4) / 60 = 45018.576 / 60 = 750 \text{ w} = 0.75 \text{ kw}$

The value of 0.75kw of power is an estimate of the required crushing power at expeller full load. In this work an electric motor of 0.75kw was used which implies that the motor will power the machine effectively without failure.

3.2.4 Expeller Screw Design Consideration

The expeller screw will be subjected primarily to torsion and as a result, torsion and compressive stresses arises in the system. Fig 1.4 Where:

V = volume of the hopper, R = outer radius (100mm), H = external height (200mm), r = inner radius (39mm), h = inner height (126mm), $\pi = 3.142$

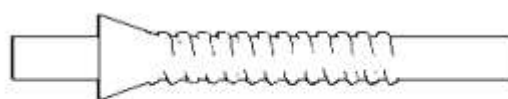

Fig 1.4: The Expeller Screw force analysis

Assumptions

1. The expeller screw is considered to be balanced tapered shaft.
2. Shaft bearing screw system is properly aligned to reduce friction.
3. The screw profile is achieved by welding metallic helical shaped on to tapered shaft.
4. Screw is considered to revolve at a steady speed.
5. The input torque is applied at the end of the screw.

The torque (T) revolves the screw, which has to overcome the crushing forces in order to bring about the required crushing. The threaded end of the shaft has to be conventional left hand helix thread. This prevents the pressure cone from loosening since the shaft has to rotate in clockwise direction. The threaded end of the shaft is subjected to direct compressive forces. The torque (T) corresponding to the power input is given by the

relation. According to Khurmi and Gupta (2004):

$$T = 9.5Pe/N \dots \dots \dots .6$$

Where:

P e = power (watts) T = Torque (N/M) N = Speed (rpm)

Khurmi and Gupta (2004) also stated that the compressive stress area of the threaded end of the expeller screw is given by

Where:

S y = yield strength of material n = factors of safety

F y = compressive force A c = compressive area D minor = minor diameter D pitch = pitch diameter

The screw profile on the expeller shaft is achieved by used of some mild steel rings formed to the desired pitch, welded on the shaft at determined positions. The body of the expeller shaft has to be maintained at 2o taper as in the design. The taper profile is achieved using a lathe machine and single point tool.

The effective length of the expeller screw is about 500mm. the torsional resistance due to crushing effect was given as 2.150N

Where:

S y = yield strength of material n = factors of safety

F y = compressive force A c = compressive area D minor = minor diameter D pitch = pitch diameter

The screw profile on the expeller shaft is achieved by used of some mild steel rings formed to the desired pitch, welded on the shaft at determined positions. The body of the expeller shaft has to be maintained at 2o taper as in the design. The taper profile is achieved using a lathe machine and single point tool.

The effective length of the expeller screw is about 500mm. the torsional resistance due to crushing effect was given as 2.150N/M=T₂ using 0.75kw electric motor, torque produced and delivered to expeller (T₁) shaft can be calculated.

From equation 5.0 that is $pe = = 2\pi N T_1 / 60$

$$T_1 = 9.5P e / N \text{ (Khurmi and Gupta (2004))}$$

Where:

P e = power = 750w calculated above

N = Shaft speed = 60 rpm calculated above Thus

$$T_1 = (60 \times 750) / (2 \times 3.142 \times 60) = 119.4 \text{ N/M}$$

Since T₁=T₂ crushing will take place without failure of the expeller shaft T₁= Expeller shaft torque

T₂= Average crushing torque

3.3 Pressure Cone Design Consideration

The adjustable pressure cone is subjected to compressive forces arising from crushing effect of the groundnut and pressing against the cone surface.

Area of the cone:

$$A_c = \pi(D_o - D_1)$$

Where:

D o = External diameter of the cone D 1 = Internal diameter of the cone

Thus, the pressure exerted by the compressive force then becomes

$$P = F / A \dots \dots \dots .9$$

This is also regarded as compressive stress (ζc) inside of the pressure cone bears a left hand helix screw thread.

The pressure cone and threaded end of the expeller shaft will be subjected to the same axial force estimated as: Given that the average force = 9.774NM from table 1.1.

Assuming 110 groundnuts at expeller full load. The total axial force = 9.774x110=1074.7N From equation 8.0

$$A_c = \pi(D_o - D_1)^2 / 4$$

From the design information External diameter (Do) = 67mm Inside diameter (D1) = 61mm Thus

$$A_c = \pi(67 \times 10^{-3} - 61 \times 10^{-3})^2 / 4 = 2.8 \times 10^{-5}$$

From equation 9.0

$$P = \sigma_c = F / A_c = 1074.7 / 2.8 \times 10^{-5} = 3.8 \times 10^{-6} \text{KN/M}^2$$

Tensile strength σ_c for medium carbon, case hardened steel (material used for the construction of the pressure cone) is, $S_u = 413 \text{MN/M}^2$

Thus from the above calculation it shows that the pressure cone will not fail.

3.4 Speed Reduction System Design

The speed deduction unit in this design is made up of belt and electric motor. The electric motor, which is coupled directly to the belt, runs at 1400rpm. The electric motor has a power output of 0.75KW and is of 50Hz single phase type.

3.5 Principle of Operation of the Groundnut Oil Expelling Machine

The principle of operation involve powering the machine and allowing it to run for about 10 minutes without any load on it. At the end of the 10 minutes, the machine should be loaded with the groundnut seeds well dried, through the feed hopper having adjusted the pressure cone to 1.0mm clearance. The adjustment should be done with the aid of hand. Finally the groundnut oil flow through the oil outlet and the cake through the cake outlet.

IV. METHODOLOGY OF FABRICATION

The machine consist of the following:

4.1 Hopper

The hopper is the feed chute with the following dimensions: High = 200mm

Smaller pyramid diameter = 78mm and Larger pyramid diameter = 200mm

Tool used for fabricating the Hopper:

Mild steel plate, welding machine, Tape rule, hacksaw

4.1.1 Cylindrical Barrel

This was fabricated to accommodate the required quantity of raw material. The barrel consist of the following dimensions:

Length of barrel = 398mm Diameter of barrel = 60mm

Diameter of the perforation on barrel = 2mm Thickness of material = 5mm

Tool used for fabricating the Barrel:

Cylindrical pipe (mild steel), Power Hacksaw, Tape rule, Vernier caliper, Drilling machine and drill bit, Filing machine.

4.1.2 Screw Shaft

This is fabricated into the following section; crushing or grinding and pressing section of the nut. Dimensions of the Screw shaft:

Length of the shaft = 500mm Diameter of shaft = 30mm

Minor diameter of the shaft = 20mm and pitch of the screw shaft = 10mm

Tool used for fabricating the screw shaft:

Medium carbon steel solid rod, Power Hacksaw, Tape rule, Vernier caliper, Lathe machine.

4.1.3 The Frame

The frame support the machine and is firmly fastened together with bolt and nut to allow easy dismount-ling. The prime mover is a 1hp electric motor of 1400rpm with belt and pulley arrangement.

Dimension of the frame Top = 394 x 200mm

Bottom = 540 x 250mm Height = 610mm

Material = 1/2 inch angle iron

Tool used for fabricating the Frame:

Hacksaw, Filing machine, Welding machine, Tape rule, Try-square.

5.0 Test Run Results

Samples of some fresh shelled groundnut seeds were collected and feed into the machine through the hopper of the machine. The machine was switched on and allowed to run for 8minutes. The result of the first run is showed in the table 1.3 below

Table 1.3: The Summary of the First test-run result

CHARACTERISTICS	TEST RESULT
Quantity of groundnut	0.78kg
Time allow for heating	8minutes
Time of crushing and extraction	10minutes
Quantity of oil	0.019kg
Quality of oil produced	Impure
Quality of cake produced	Not dry

Re-Test Run

As a result of the quality of the oil and cake produced, it became necessary to perform a re-test run. The time allowed for the machine to heat up was increased to 15 minutes and the following results were obtained a shown in table 1.3 below:

Table 1.3: The Summary of the Re-test-run result

CHARACTERISTICS	TEST RESULT
Quantity of groundnut	0.78kg
Time allow for heating	15minutes
Time of crushing and extraction	10minutes
Quantity of oil	0.23kg
Quality of oil produced	pure
Quality of cake produced	Dry

V. RESULT DISCUSSION

From the test result, it was observed that the quality of oil obtained when 8 minutes time was allowed for the machine at motion to generate heat before pouring the groundnut was impure. But when the time was increased to about 15 minutes, the quality of oil was improved.

VI. CONCLUSION

We have designed, fabricated and tested a groundnut oil expelling machine. The relative performance test result shows that the machine maintained high level of oil extraction characteristics in terms of cake quality and oil quality. The machine is cheap and could easily fit into medium and large scale industry for the production of groundnut oil in commercial quantity. The machine is easy and safe to operate, has a low energy consumption rate and do not pollute the environment. Finally, we have realized our aim. Though the machine has a higher oil extraction rate, there exist some need for improvement on it.

RECOMMENDATION

We recommend that more work be done on the extraction efficiency of the machine in other to improve its oil extraction rate. Also the incorporation of sensors in the feed screw in other to avoid the over loading of the machine should be duly considered. As a result of the observation made during the test run, we also recommend that in subsequent design, the oil extraction rate and residual oil in cake should be analyzed to improve on the machine effectiveness. Finally we recommend that subsequent design should include Automation system in other to reduce human labour and heating element which will heat the groundnut for efficient oil production.

REFERENCES

- [1]. Bachman, J. (2001), Small scale oilseed production. Available online at; www.attar.ncat.org/pub/oilseed.html
- [2]. Khangar, V. S. & Jaju, S. B. (2012), A Review of Various Methodologies Used for Shaft Failure Analysis, International Journal of Emerging Technology and Advanced Engineering, ISSN 2(6), 2250-2459.
- [3]. Khrmi, R.S & Gupta, J.K (2004), Theory of Machines, Eurasia publishing housing, New Delhi.
- [4]. Khrmi, R.S & Gupta, J.K (1998), A textbook of Machine Design, 14 Edition, New Delhi, Eurasia publishing housing (PVT) Ltd., (chapter 7&14).
- [5]. Maul, K., Modh, J. & Mevada, R. (2011), Design, Improvement and Thrust Bearing Analysis of Oil Expeller Machine, Int J EnggTechsci 2(3), 246-252.
- [6]. Saeed, M.A, (1991), workshop on small scale oil expelling system, Japan; Available online at; www.icdr.ca/library/document
- [7]. Miwa, S. (1990), The history of grinding implements for domestic use, available online at; www.bigaine.ip
- [8]. Shafiq, A. (1991), national workshop on small scale oil expelling system, Pakistan, 2-29

APPENDIX A



APPENDIX B



APPENDIX C

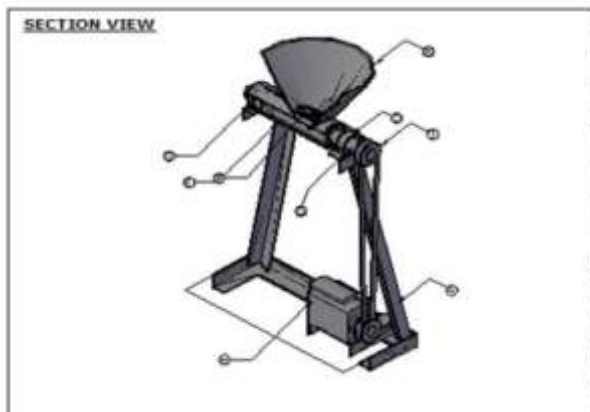

APPENDIX D

PART DRAWING

PART LIST

S/N	NAME	MATERIAL	QTY
A	Main frame	Mild steel	1
B	Hopper	Mild steel	1
C	Outlet	Mild steel	2
D	Bearing	Mild steel	1
E	Cylindrical Barrel	Mild steel	1
F	Press Screw shaft	Medium carbon steel	1
G	Cone	Medium carbon steel	1
H	Pulley, Belt & motor	Mild steel	1