



## ELECTRIC –BIKE

A.Senthil kumar<sup>1</sup>, G.Jagruthi<sup>2</sup>,M.Bhanu prakash<sup>3</sup>,J.Gireesha<sup>4</sup>,N.Sreenath<sup>5</sup>,A.Uday kiran<sup>6</sup>

### ABSTRACT

The primary objective of the project is to design a feasible yet highly adaptable E-bike. As the number of motor vehicles on the roads throughout the world increases at staggering rate each year, the dependence on oil-based fuel grows almost unchecked. The increased use of non-renewable fossil fuels brings with it environmental problems such as: the “greenhouse effect”, health problems for city dwellers and concern over the stability of fuel supply. To move away from this dependence on oil, a vast amount of money is being spent on the development of electrical vehicles (EVs) that may be produced. This project presents a study of electrical motorcycle design. The aim of this project is to investigate how to design a simple, cost effective model of electrical motorcycle with intelligent control system. This can be implemented by removing the internal combustion engine, the exhaust system and other unnecessary components from the motorcycle and replaced by an electrical motor, an intelligent controller, and a battery pack, cabling system and monitoring instruments.

### INTRODUCTION

An electric bike is, first and foremost, a bike. It uses the same designs, geometries, and components as any other bike, but also includes an added electric motor. This is fueled by a rechargeable battery, which gives riders an extra boost of power and ultimately provides a smoother, more convenient, and less strenuous cycling experience. By eliminating many of the obstacles that keep people from cycling—obstacles such as headwinds, steep hills, and bike commutes that leave riders tired, messy, and sweaty—electric bikes help make the freedom, exhilaration, and satisfaction of cycling available and accessible to a wide range of potential cyclists.

The idea of creating an electric bike has intrigued cyclists since the late 1800s, when several American inventors experimented with the possibility of combining the potential power of electric motors with the simple mechanics of the bicycle. It wasn't until the technological advancements of the 20th and 21st centuries, however, that this idea finally became a viable reality. With lightweight motors, high efficiency rechargeable batteries, smoothly shifting drivetrains, and huge advances in bike components,

today's electric bikes provide a way for cyclists of all ages, fitness levels, and physical needs to enjoy the benefits of cycling, whether it's a leisure ride, a workout, or part of a daily commute. For many, electric bikes are an attractive alternative to both conventional bicycles and traditional automobiles, providing an environmentally friendly, fun, efficient, and convenient way to travel.

## PROPOSED SYSTEM

It is made up of a battery, a BLDC motor drive, and its controller, as well as a throttle valve. The proposed E-Bike uses a lithium ion battery to power the BLDC motor, which has its shaft coupled to a small chain sprocket. Lithium ion batteries are commonly used in EVs due to their high battery efficiency, low maintenance, and high charge power. It is powered by a 48 V, 12 AH lithium ion battery. The next form of motor is the Brushless DC motor, which is also known as an electronically commutated motor. It is used to transform electrical energy into mechanical energy in this case. It is driven by DC power, which is converted to AC power by an electronic commutator or inverter and used to drive each step. In an E-Bike, the motor controller unit is used to control the power conversion operation. Hall sensors in the BLDC motor recognise the rotor direction angle [6]. These sensors are installed in the motor's rotor and linked to the motor controller as input. Hall sensors needed DC power, which was provided by a motor controller. Three wires supply stages, two wires supply hall sensors, and the remaining three wires receive input from the hall sensors in a BLDC motor [6, 8]. To control the speed of the hub motor, a feedback signal is needed (48 V, 12ah, 800 W, -3000 rpm). This motor is more suitable for EVs because of their (i) Better speed versus torque characteristics (ii) Noiseless operation (iii) High efficiency (iv) Long operating life (v) High dynamic response (vi) Higher speed ranges

## PROPOSED SYSTEM SPECIFICATIONS

### 1. Battery-48v, 12ah

Lithium-ion (li-ion) battery are the best option for e-bikes. Although lead-acid batteries are significantly cheaper, they're three times as heavy as their li-ion equivalents. Li-ion has several variants of cell chemistry

### 2. Motor-800w, 3000 rpm

The hub motors belong to the family of dc motors. they do not have any commutator and brush mechanism to produce excitation in windings. in a hub motor, the stator is a stationary part that has a core and slots where the copper windings are incorporated on slots. most of the hub motors have trapezoidal winding

### 3.Controller-36v

The motor controller is also known as the electric e-bike controller or electric speed controller. It is a circuit board in a sealed protective box with several connection wires sticking out.

If the motor acts as the “heart” of an e-bike, then the controller is their “brain,” which is the main factor to determine the performance of an e-bike.

### 4.Throttle

### 5.Brakes

### 6.Speed Sensor

### 7.Head light

### 8.Gear system

## BLOCK DIAGARM:-

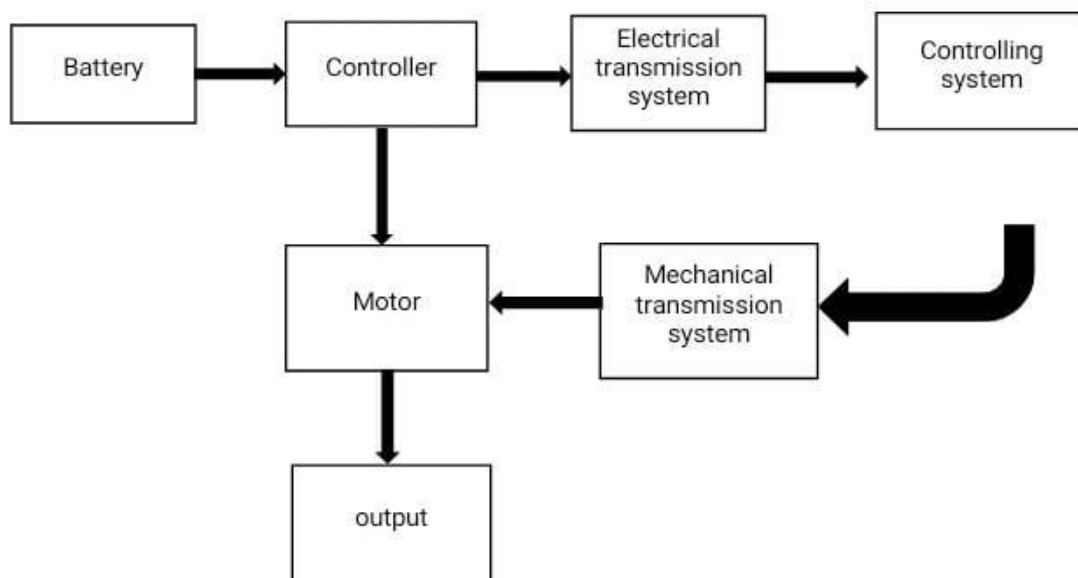

## WORKING

Electric bikes work the same way as the normal bicycles work, except that e-bikes come with a battery-assisted motor that helps in paddling the bike. Therefore, an electric bike has three main components that include-

- The E-bike motor
- The E-bike battery
- Controller or assistance

The most common type of motor for electric bikes is called a hub motor. It is generally integrated into the rear or front wheel. When engaged, it pulls or pushes the wheel along. Although this system works well, it has one key disadvantage. Since it is not connected to the bike's gears, it loses efficiency on hills and varied terrain. Imagine driving a vehicle in just one gear the entire day. It will get you places, but it won't give you the optimum amount of torque or speed that you get with a full gear range.

### MODEL

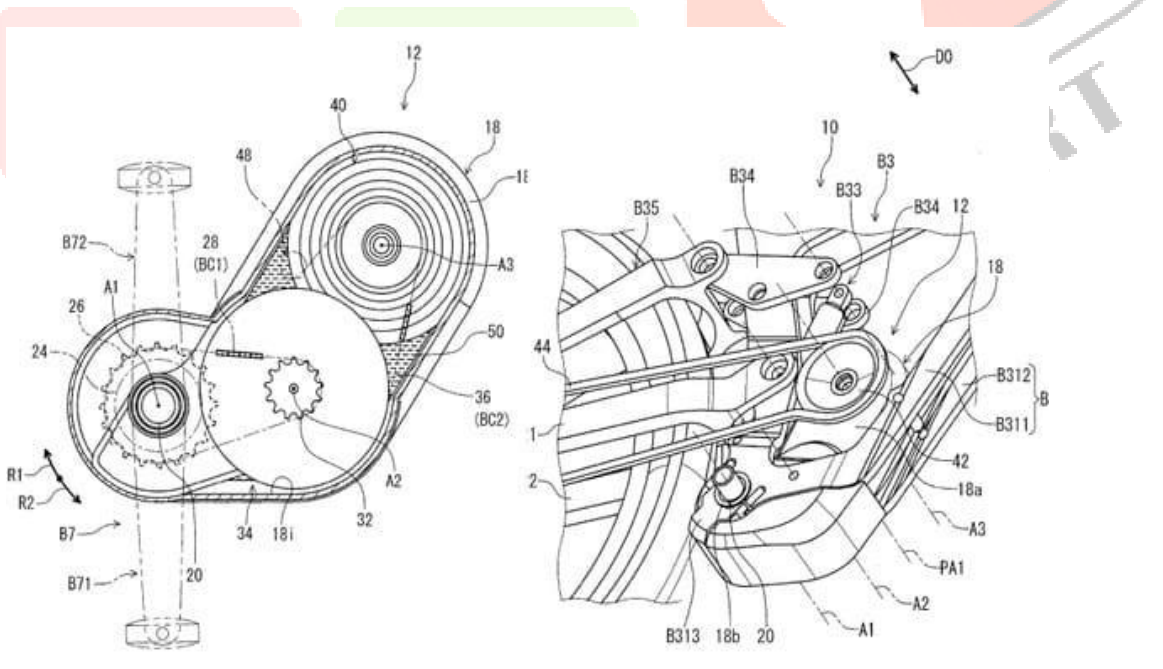

## OUTPUT



## CONCLUSION

The progress that the electric vehicle industry has seen in recent years is not only extremely welcomed, but highly necessary in light of the increasing global greenhouse gas levels. As demonstrated within the economic, social, and environmental analysis sections of this webpage, the benefits of electric vehicles far surpass the costs. The biggest obstacle to the widespread adoption of electric-powered transportation is cost related, as gasoline and the vehicles that run on it are readily available, convenient, and less costly. As is demonstrated in our timeline, we hope that over the course of the next decade technological advancements and policy changes will help ease the transition from traditional fuel-powered vehicles. Additionally, the realization and success of this industry relies heavily on the global population, and it is our hope that through mass marketing and environmental education programs people will feel incentivized and empowered to drive an electric-powered vehicle. Each person can make a difference, so go electric and help make a difference!

## REFERENCES

- [1]. S. Matey, A. Prabhu, "Design and Fabrication of Electric Bike" International Journal of Mechanical Engineering and Technology- Vol. 8 Issue 3- March (2017).
- [2]. A. Jain, P. Sarkar, K. Siddique, "Controlling of Permanent Magnet Brushless DC Motor using Instrumentation Technique" International Journal Advance Engineering and Research Development- Vol. Issue 1- (2015).
- [3]. O. Shimamura, T. Abe, K. Watnabe, Y. Ohsawa, H. Horie "Research and Development Work on Lithium-ion Batteries for Environmental Vehicles" The World Electric Vehicle Association Journal, Vol. 1, (2007)
- [4]. J. Godenough, M. Whittingham, A. Yoshino "Li-Ion Batteries" Kungl. Vetenskaps-akademein (2019).
- [5]. A. kumar, A. Dewangan, V. Dange, A. Agrawal "Eco-Friendly E-Bicycle" International Journal of Recent Technology and Engineering (IJRTE) ISSN: 2277-3878, Volume-8 Issue-5, January (2020).

