



MACHINE LEARNING BASED MODEL FOR PREDICTION OF NEURODEVELOPMENTAL DISORDER

1Dhanush Vasudevaraju, 2Sandhya A Kulkarni, 3C Ramesh Chandra, 4Dinesh M, 5C Sai Ranganath
1Student, 2Assistant Professor, 3Student, 4Student, 5Student

1K S School of Engineering and Management,

2K S School of Engineering and Management,

3K S School of Engineering and Management,

4K S School of Engineering and Management,

5K S School of Engineering and Management

Abstract — Autism spectrum disorder is a neurodevelopmental disorder that affects a person's interaction, communication and learning skills. Although diagnosis of autism can be done at any age, its symptoms generally appear in the first two years of life and develop through time. Autism patients face different types of challenges such as difficulties with concentration, learning disabilities, mental health problems such as anxiety, depression, motor difficulties, sensory problems, and many others. Diagnosis of autism requires significant amount of time and cost. Earlier detection of autism can come to a great help by prescribing patients with proper medication at an early stage. It can prevent the patient's condition from deteriorating further and would help to reduce long term costs associated with delayed diagnosis. Thus, an efficient, accurate and easy screening test tool is very much required which would predict autism traits in an individual. The main idea behind this project is to detect autism spectrum disorder in an individual (male/female). This project is implemented by making use of a Machine Learning model using parameters such as an individual's age, gender, ethnicity, Autism Quotient Tool. The detection derived from this project will help an individual to get required diagnosis in time to prevent further complications of developing Alzheimer's disease.

I. INTRODUCTION

Autism spectrum disorder is a neurodevelopmental disorder that affects a person's interaction, communication and learning skills. Although diagnosis of autism can be done at any age, its symptoms generally appear in the first two years of life and develop through time. Autism patients face different types of challenges such as difficulties with concentration, learning disabilities, mental health problems such as anxiety, depression etc, motor difficulties, sensory problems and many others. Diagnosis of autism requires significant amount of time and cost. Earlier detection of autism can come to a great help by prescribing patients with proper medication at an early stage. It

can prevent the patient's condition from deteriorating further and would help to reduce long term costs associated with delayed diagnosis. Thus a time efficient, accurate and easy screening test tool is very much required which would predict autism traits in an individual and identify whether or not they require comprehensive autism assessment.

The objective of this work is to propose an autism prediction model using ML techniques and to develop a mobile application that could effectively predict autism traits of an individual of any age. In other words, this work focuses on developing an autism screening application for predicting the ASD traits among people of age groups 0-3 years and 4-13 years.

II. RELATED WORK

Current explosion rate of autism around the world is numerous and it is increasing at a very high rate. According to WHO, about 1 out of every 160 children has ASD. Some people with this disorder can live independently, while others require life-long care and support. Diagnosis of autism requires significant amount of time and cost.

Earlier detection of autism can come to a great help by prescribing patients with proper medication at an early stage. It can prevent the patient's condition from deteriorating further and would help to reduce long term costs associated with delayed diagnosis. Thus, a time efficient, accurate and easy screening test tool is very much required which would predict autism traits in an individual and identify whether or not they require comprehensive autism assessment.

The main purpose of this project is to develop an application to implement a machine learning based solution that can detect Autism Spectrum Disorder in an individual (male/female) during early stages for early diagnosis using efficient algorithms to obtain results with required accuracy. Then, design and develop an user-interface for user to interact.

III. INCORPORATED PACKAGES

A. Python

Python is a computer programming language often used to build websites and software, automate tasks, and conduct data analysis. Python is a general-purpose language, meaning it can be used to create a variety of different programs and isn't specialized for any specific problems. The python interpreter and the extensive standard library are available in source or binary form without charge for all major platforms, and can be freely distributed.

B. Jupyter Notebook

The Jupyter Notebook App is a server-client application that allows editing and running notebook documents via a web browser. The Jupyter Notebook App can be executed on a local desktop requiring no internet access (as described in this document) or can be installed on a remote server and accessed through the internet.

C. User-Interface

The user interface is the point at which human users interact with a computer, website or application. The goal of effective UI is to make the user's experience easy and intuitive, requiring minimum effort on the user's part to receive the maximum desired outcome.

D. Support Vector Machines

Support Vector Machines (SVMs), also support vector networks are supervised learning models with associated learning algorithms that analyze data used for classification and regression analysis. It is formally defined by a separating hyperplane. In other words, given labeled training data (supervised learning), the algorithm outputs an optimal hyperplane which categorizes new examples.

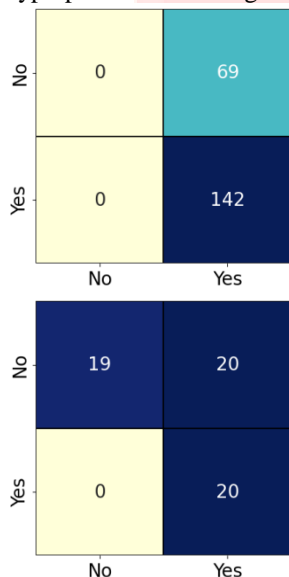

Figure 1: Confusion Matrix for SVM

E. Artificial Neural Network

An ANN is based on a collection of connected units or nodes called artificial neurons, which loosely model the neurons in a biological brain. Each

connection, like the synapses in a biological brain, can transmit a signal to other neurons. An artificial neuron receives signals then processes them and can signal neurons connected to it. The "signal" at a connection is a real number, and the output of each neuron is computed by some non-linear function of the sum of its inputs. The connections are called *edges*. Neurons and edges typically have a *weight* that adjusts as learning proceeds. The weight increases or decreases the strength of the signal at a connection. Neurons may have a threshold such that a signal is sent only if the aggregate signal crosses that threshold.

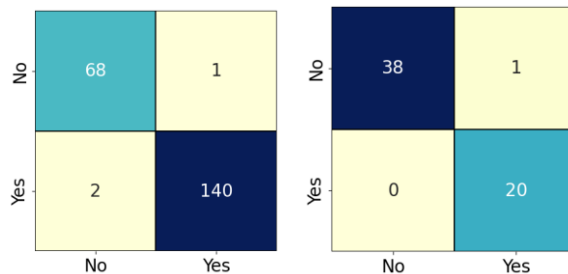

Figure 2: Confusion matrix for ANN

F. Random Forest Algorithm

Random forests or random decision forests are an ensemble learning method for classification, regression and other tasks that operates by constructing a multitude of decision trees at training time and outputting the class that is the mode of the classes or mean prediction of the individual trees.

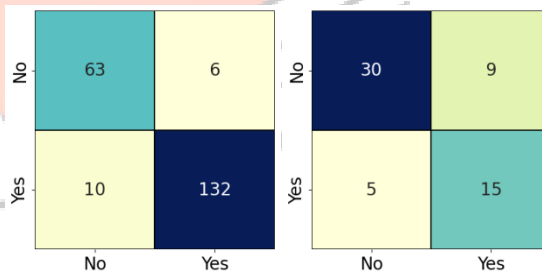

Figure 3: Confusion Matrix for Random Forest Algorithm

IV. THE PROPOSED METHOD

Our proposed strategy focuses on a novel machine learning procedures for Autism spectrum disorder (ASD) classification and prediction, thus overcoming the existing problem. By utilizing Random Forest (RF), Support Vector Machine(SVM), ANN algorithms we will make our model in order to increase the performance and accuracy. This method has multiple advantages such as - we don't have to figure out the features ahead of time, it is more effective, fault tolerant and scalable.

Different existing data mining procedures and its application were considered or explored. Utilization of machine learning algorithms was connected in various medical data sets. Machine learning strategies have diverse power in different medical data sets. In this work, a business intelligent model has been developed specific business structure deal with Autism classification using a suitable machine learning

technique. The model was evaluated by a scientific approach to measure accuracy. We are using Random forests, Support Vector Machines to build our model. Then, we make use of ANN algorithm. ANNs are composed of artificial neurons which are conceptually derived from biological neurons. Each artificial neuron has inputs and produces a single output which can be sent to multiple other neurons. After model construction it is time for model training. We were able to build an Random Forest, Support Vector Machine and ANN to recognize Autism Spectrum Disorder(ASD). In the next step, we will split the dataset into train dataset and test dataset. Then, we will build and train the model using training dataset. Finally, we will design an user-interface for any user to get the predicted results.



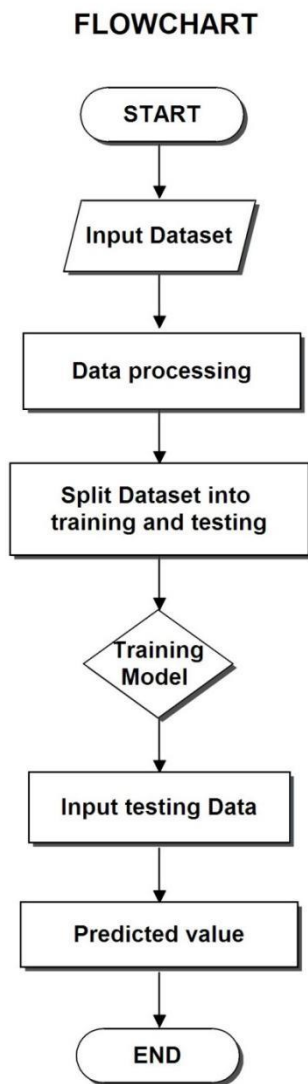

Fig 4: Proposed system

In this final phase, we will test our classification model on our prepared image dataset and also measure the performance on our dataset. To evaluate the performance of our created classification and make it comparable to current approaches, we use accuracy to measure the effectiveness of classifiers.

After model building, knowing the power of model prediction on a new instance, is very important issue. Once a predictive model is developed using the historical data, one would be curious as to how the model will perform on the data that it has not seen during the model building process. One might even try multiple model types for the same prediction problem, and then, would like to know which model is the one to use for the real-world decision making situation, simply by comparing them on their prediction performance (e.g., accuracy). To measure the performance of a predictor, there are commonly used performance metrics, such as accuracy, recall etc. First, the most commonly used performance metrics will be described, and then some famous estimation methodologies are explained and compared to each other. "Performance Metrics for Predictive Modeling In classification problems, the primary source of performance measurements is a coincidence matrix (classification matrix or a contingency table)".

Below figure shows a coincidence matrix for a two-class classification problem.

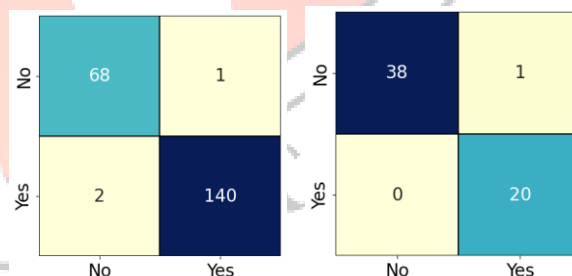

Figure 6: Confusion matrix

As being seen in above figure, the numbers along the diagonal from upper-left to lower-right represent the correct decisions made, and the numbers outside this diagonal represent the errors. "The true positive rate (also called hit rate or recall) of a classifier is estimated by dividing the correctly classified positives (the true positive count) by the total positive count. The false positive rate (also called a false alarm rate) of the classifier is estimated by dividing the incorrectly classified negatives (the false negative count) by the total negatives. The overall accuracy of a classifier is estimated by dividing the total correctly classified positives and negatives by the total number of samples.

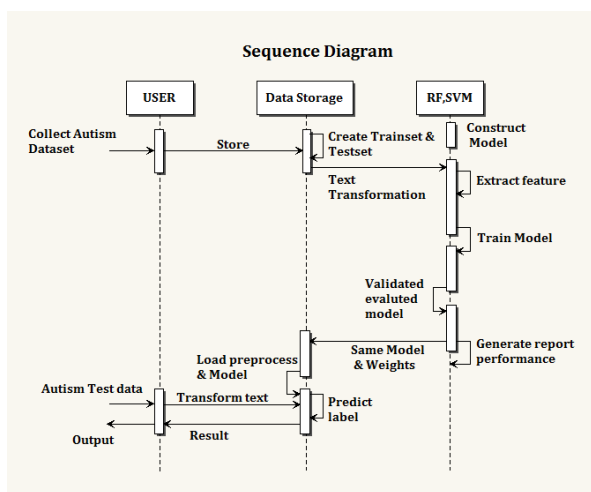

Fig 5: Sequence Diagram

VI. CONCLUSIONS

This system comes under machine learning which is advanced technique at present. RF, ANN, is more suitable for numerical processing especially in medical classification. We conclude the experimental result what we are getting from developed system is 99% and 98% accurate for child and toddler datasets

respectively. We have also compared all three algorithms as shown below.

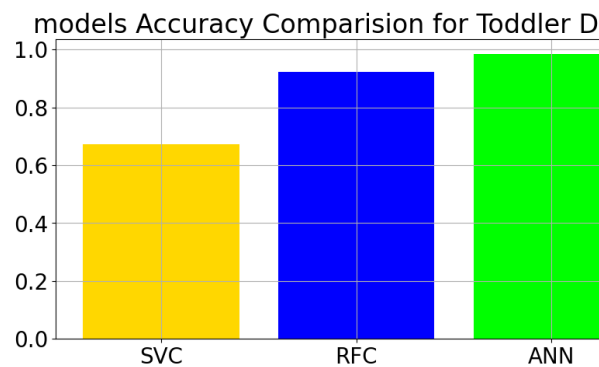

Figure 7: Model Comparison

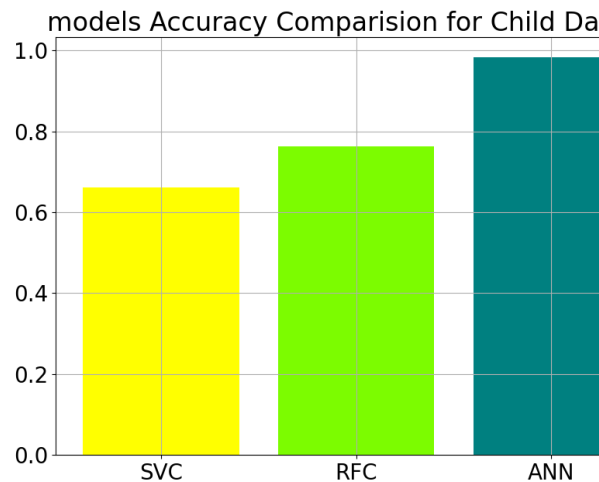

Figure 8: Model Comparison

REFERENCES

[1] Omar, Kazi Shahrukh, Prodipta Mondal, Nabila Shahnaz Khan, Md Rezaul Karim Rizvi, and Md Nazrul Islam. "A machine learning approach to predict autism spectrum disorder." In 2019 International conference on electrical, computer and communication engineering (ECCE), pp. 1-6. IEEE, 2019. doi:10.1109/ecace.2019.8679454

[2] Akter, Tania, Md Shahriare Satu, Md Imran Khan, Mohammad Hanif Ali, Shahadat Uddin, Pietro Lio, Julian MW Quinn, and Mohammad Ali Moni. "Machine learning-based models for early stage detection of autism spectrum disorders." IEEE Access 7 (2019): 166509-166527. doi:10.1109/access.2019.2952609

[3] Baranwal, Astha, and M. Vanitha. "Autistic spectrum disorder screening: prediction with machine learning models." In 2020 International conference on emerging trends in information technology and engineering (ic-ETITE), pp. 1-7. IEEE, 2020. . doi:10.1109/ic-etite47903.2020.186

[4] Eni, M, Dinstein, I, Ilan, M., Menashe, I, Meiri, G, & Zigel, Y. (2020). Estimating Autism Severity in Young Children From Speech Signals Using a Deep Neural Network. IEEE Access, 8, 139489–139500. doi:10.1109/access.2020.301253

[5] Raj, S, & Masood, S. (2020). Analysis and Detection of Autism Spectrum Disorder Using Machine Learning Techniques. Procedia Computer Science, 167, 994-1004. doi:10.1016/j.procs.2020.03.39

[6] Mamun, K. A. A., Bardhan, S., Ullah, M. A., Anagnostou, E., Brian, J., Akhter, S., & Rabbani, M. G. (2016). Smart autism — A mobile, interactive and integrated framework for screening and confirmation of autism. 2016 38th Annual International Conference of the IEEE Engineering in Medicine and Biology Society (EMBC). doi:10.1109/embc.2016.7592093

[7] F. Thabtah, F. Kamalov, and K. Rajab, "A new computational intelligence approach to detect autistic features for autism screening," Int. J. Med. Inform., vol. 117, pp. 112_124, Sep. 2018. https://doi.org/10.1016/j.ijmedinf.2018.06.009

[8] F. Thabtah and D. Peebles, "A new machine learning model based on induction of rules for autism detection," Health Inform. J., 2019, Art. no. 1460458218824711, doi: 10.1177/1460458218824711.

[8] M. S. Satu, F. F. Sathi, M. S. Arifen, M. H. Ali, and M. A. Moni, "Early detection of autism by extracting features: A case study in Bangladesh," in Proc. 1st Int. Conf. Robot., Elect. Signal Process. Techn. (ICREST), Jan. 2019, pp. 87_90. doi: 10.1109/ICREST.2019.8644357

[9] H. Abbas, F. Garberson, E. Glover, and D. P. Wall, "Machine learning approach for early detection of autism by combining questionnaire and home video screening," J. Amer. Med. Informat. Assoc., vol. 25, no. 8, pp. 1000_1007, 2018. doi:10.1093/jamia/ocy039

[10] F. Thabtah, "Machine learning in autistic spectrum disorder behavioral research: A review and ways forward," Informat. Health Social Care, vol. 44, no. 3, pp. 278_297, 2018. doi:10.1080/17538157.2017.1399132