

Li-Fi Based Home Automation System

Dr. J. W. Bakal, Chaitali Kadam, Aniket Polekar, Sanchita Kolekar
Principal, UG Student, UG Student, UG Student
Department of Computer Engineering
Shivajirao S. Jondhale College of Engineering
University of Mumbai, India

Abstract - Internet has become the requirement for the hour. With new technologies being developed day by day the requirement for net has conjointly up, with the event of the web speed of transmission conjointly needs to extend. Li-Fi may be thought lightweight of sunshine} based mostly Wi-Fi because it uses light rather than radio waves to transmit data. And rather than Wi-Fi modems, Li-Fi might use transceiver fitted diode lamps which will light-weight a space further as transmit and receive data. Since straightforward light-weight bulbs are used, there may be multiple access points. This paper focuses on the operating of Li-Fi. The transmitter (LED) and receiver section (Photo diode) alongside ATMEGA16 we've designed and analyzed the performance. With average information rates up to 75-80kbps was achieved in indoor lamination at a distance of zero.6-0.8m.

Home Automation involves introducing the degree of automatic management to concern physics system. Li-Fi may be used for the quick increasing gadgets and to boost simpler use of sunshine. Li-Fi uses diode lights that helps in quicker and versatile information transfer transmitted through Wi-Fi.

Keywords—Android application; Web server; Transmitter; Receiver; GPRS.

• INTRODUCTION

Li-Fi:

Li-Fi stands for Light-Fidelity; it refers to 5G communication system. Transfer of information from one place to a different or from one device to a different has become one in all the foremost vital day to day activities. The thought of Li-Fi is of whole lot of interest because it provides associate degree alternate answer of information transfer victimization the visible radiation spectrum than the overcrowded RF spectrum.

So here, there's ten,000 times extra space accessible during this spectrum and simply relying on the bulbs in use, it additionally multiplies to ten,000 times additional convenience as associate degree infrastructure, globally.

Home Automation:

Home automation is building automation for a home, referred to as sensible home or smart house. It involves the management and automation of lighting, heating (such as good thermostats), ventilation, air-conditioner, and security, furthermore as home appliances like washer/dryers, ovens or refrigerators/freezers. Wi-Fi is employed for remote observation and management. usually trendy systems accommodates switches and sensors that area unit connected to a central hub is named a "gateway" from that the system is controlled with a computer program that's interacted either with a wall-mounted sockets, mobile software package, computer, however not continually via net cloud services.

Home Automation using Li-Fi:

Home automation may be represented as introduction of technology among the house surroundings to produce convenience, comfort, security and energy potency to its occupants. Adding automation to home surroundings will offer quality of life. With the introduction of the Li-Fi analysis and implementation of home automation have gotten additional in style. Presently several researches have done that offer several home automation facilities with Li-Fi.

• LITERATURE REVIEW

The system is proposed based on the review of some previous work in the home automation using Li-Fi.

R. A. Ramlee presents the overall design of Home Automation System (HAS) with low cost and wireless remote control. It is designed to provide support in order to fulfill the needs of elderly and disabled in home. The control system uses wireless Bluetooth technology and provides remote access from PC/laptop or smart phone. ^[1]

S. Benjamin Arul presents the home automation system is used to control electrical appliances in a home or office using voice commands. It includes voice recognition response test and ZigBee communication test. [2]

Olivier Bouchet experimented the use of networks are typically constituted by some tens of devices connected to each other via a set of wired and wireless technologies. [3]

Sharon Panth presents the automated approach of controlling the devices in a household that could ease the tasks of using the traditional method of the switch. [4]

Sinku U. Gupta presents the LIFI which uses LED lights which helps in faster and flexible data transfer transmitted through Wi-Fi. As light is everywhere, using light as the transmission medium Li-Fi can provide wireless indoor communication. The data transfer through LIFI is in bits and is much faster than Wi-Fi. [5]

Zashi P. Chaudhari and Satish R. Sonawane presents High sensitivity universal Li-Fi receiver for enhance data communication, which is safe for human being and so secure to use. But obstacles can harm the project or destroy the concept by interfering the line of site. [6]

Chien-Hung Lai and Yuh-Shyan Hwang, presents a wireless cross-platform interactive home automation system for long-term care facilities, based on the commercially available card-size embedded systems Banana Pi M1 and Intel® Edison. [7]

Monica Leba, paper summarizes most of the research, developments and applications achieved so far and looks at the different aspects of the strengths and weaknesses, implementations, challenges and data modulation techniques of the VLC and specific Li-Fi's new coined optical wireless communication technology. [8]

- **EXISTING SYSTEM**

It is exploitation Wi-Fi module for home automation. The most four challenges of home automation systems are, high value of possession, inflexibility, poor traceableness, and issue achieving security. the most objectives of existing system is to style and to implement an inexpensive and open supply home automation system that's capable of automating the house appliance through a simple internet interface to run and maintain the house automation system.



Figure 1 Existing system

• DRAWBACKS OF EXISTING SYSTEM

- 1) **Less security:** Radio waves will go through walls and may be intercepted and can be misuse easily.
- 2) **Less capacity:** Wireless data is transmitted through radio waves which are short and high of cost, it has only the limited bandwidth.
- 3) **Low efficiency:** There are 1.4 million mobile radio base stations that consume maximum energy. Efficiency of such stations is only 5%.
- 4) **Less availability:** In aero planes and the places like petrol pumps and petrochemical plants, the mobile can't be able to use, because it is not safe at all.

• PROPOSED SYSTEM

This System Mainly Contains Following Blocks:

1) Android Application:

Home Automation by android application based remote control. The main purpose of this project is to design Home Automation System with Android Application which can be controlled remotely. This proposed system uses an Android application which can be operated on Smartphone or tablet.

The Android Based Application can turn on and turn off the device upon the need of the user.

2) Web Server:

Web Server is the mediator between the remote Android OS mobile application and the transmitter of the home automated device. It receives the command from the commands through internet via the GPRS chipset built in the transmitter.

3) Transmitter:

Mobile application provided it is connected to the internet. The main function of the transmitter is to receive commands from the web server via GPRS chipset and convert the command into binary bits. It then transfers this binary information to the receiver via the Li-Fi module.

4) Receiver:

The receiver receives the binary information from the transmitter via Li-Fi Module and encrypts the binary data into machine readable language. It then transfers the information to relays, which is connected to the devices and they act upon the data provided.

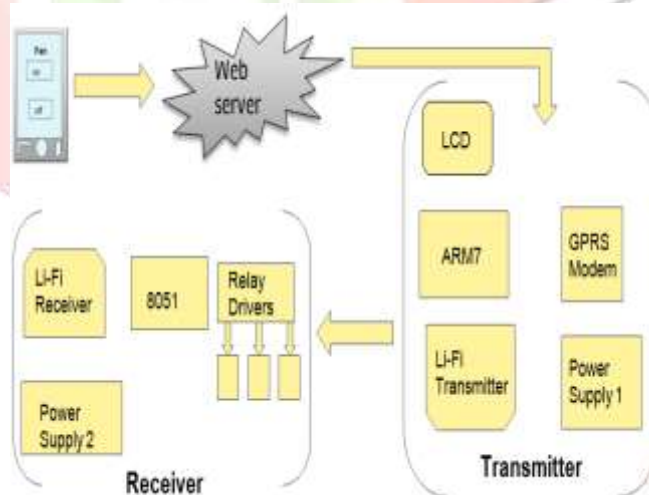

Figure 2 Block diagram of proposed system

• FEATURES

- 1) **Security:** Light waves do not penetrate through walls and they can't be intercepted and misused. With the help of Li-Fi, it is not mandatory to be in a region that is Wi-Fi enabled to have connected to the internet.

2) **Capacity:** Compared to radio signals, the bandwidth of light is 10000 time wider. The light sources are already installed so that Li-Fi has got best capacity and the equipments are already available.

3) **Efficiency:** The data transmission using Li-Fi is very cheap, less energy and highly efficient.

4) **Availability:** All over the place, the light source is present so availability is not an issue. In worldwide they will be numerous light bulbs available and they are needed to be replaced with LEDs for proper transmission of data.

• RESULT

The following results are obtained by sending the text data from the transmitter to the receiver via Li-Fi.

Table A: For text transfer

| Size | Time (sec) | Data rate(kbps) |
|-------|------------|-----------------|
| 320KB | 34 | 75.29 |
| 550KB | 59 | 74.64 |
| 795KB | 96 | 65.84 |
| 981KB | 124 | 63.28 |

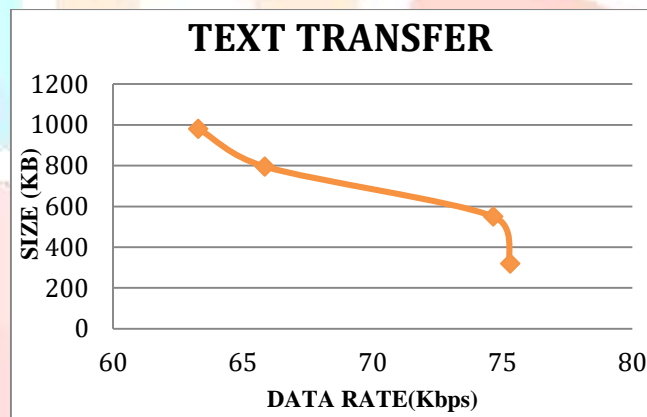

Figure 3 Data rates during text transfer

• CONCLUSION AND FUTURE SCOPE

Li-Fi has provided consecutive step of invention within the world of communication, it's safe to any or all species together with humans and progressing towards a greener, less costly and brighter way forward for technologies. To supply the new method of communication channels with the assistance of already existing instrumentality and conjointly to resolve the deficiency of frequency information measure, we've used Li-Fi. Therefore in future work we have a tendency to be attempting to beat the demerits of existing system and developed the planned system. We've overcome demerits like outside communication with the device, upgraded the safety and conjointly given method for quicker knowledge transmission.

• REFERENCES

- [1] R.A.Ramlee, M.H.Leong, R.S.S.Singh, M.M. Ismail, M. A. Othman, H. A. Sulaiman, M.H.Misran, M. A. Meor Said "Bluetooth Remote Home Automation System Using Android Application", 2013.
- [2] S. Benjamin Arul,"Wireless Home Automation System Using Zigbee", 2014.
- [3] Olivier Bouchet, Jean-Philippe Javardin," ACEMIND: The smart integrated home network", 2014.

- [4] Sharon Panth, Mahesh Jivani, "Home Automation System (HAS) using Android for Mobile Phone", 2014.
- [5] Sinku U. Gupta, "Research on Li-Fi Technology & Comparison of Li-Fi/Wi-Fi", 2015.
- [6] Zashi P. Choudhari, "High sensitivity universal Li-Fi receiver for enhance data communication", 2016.
- [7] Chien-Hung Lai and Yuh-Shyan Hwang, "Wireless Cross-Platform Interactive Home Automation System for Long-Term Care Facilities", 2017.
- [8] Monica Elba, Simon Eritrean, Andréa Ionic, "Li-Fi – the Path to a New Way of Communication", 2017.

