

# PC BASED MAXIMUM DEMAND CONTROLLER FOR LOAD TRIPPING

<sup>1</sup>R.DHARANI, <sup>2</sup>S.JANANI, <sup>3</sup>P.SRIDEVIPONMALAR

Department of Electrical and Electronics Engineering  
New Prince Shri Bhavani College of Engineering and Technology,  
Chennai, Tamilnadu, India.

**Abstract:** At present industries are using an individual controller for controlling their individual parameters. The main aim of this project is to use a single controller for controlling more than one parameter in a fully automatic mode. In our state, there is a scarcity of electrical energy due to which EB provide limited amount of energy for us to utilize, which when exceeded we have to pay penalty. In order to overcome this problem in our project we have designed a low cost PIC microcontroller which will sense on load utilization and will send the control signal to the load tripper relay in such a way near our consumption does not exceed. Also it prevents us from paying penalty to EB. This project help in maintain data base and also, gives a voice command and in addition 2 phase voltage, current, and power can be monitored and controlled.

**Keywords:** controller, EB, load, automatic mode.

## 1. INTRODUCTION

Maximum demand is the power consumed over a predetermine period of time, which is usually between 8-30 minutes. The power is calculated and billed by a KW demand meter. It records the highest KW once in 15 minutes period over a month's time. In industrial process continuous electric supply plays a major role. The electricity bills are fixed running cost with good maximum demand controller. The maximum KVA used during a month can be reduced by continuous monitoring and control the maximum demand by using the embedded PIC micro controller. The penalty will be calculated as follows

$$500\text{KVA} \times 48 \text{ cycles} \times 60 \text{ days} + 100 \text{ percent penalty.}$$

HT consumers have to pay a maximum demand charge in addition to the usual charge for the number of units consumed. It is necessary to monitor power use and to turn off or reduce non-essential loads. Maximum demand controller is a device designed to meet the need of industries conscious of the value of load management. Demand control scheme is implemented by using suitable control contactors. Audio and visual annunciations could also be used. This project can be used for load management in industries and also to avoid the penalties and production losses [2]. Maximum demand is the greatest demand of the load on the Power station during a given period Uncontrolled maximum demand can affect the whole power system. There is possibility of unwanted power transmission and unwanted utilization due to uncontrolled maximum demand. Hence, it is important to control maximum demand [3]. Higher power consumption by an industry leads to huge bills along with penalties too. In order to avoid penalties, Maximum demand refers to the maximum amount of electrical energy that is being consumed at a given time. It is measured in kilowatts per hours, which is a measurement of total electricity used for a period of time. The purpose of controlling the demand is, not to exceed the preset maximum demand limit. One way to do this is to shed non-critical loads with respect to time. There are possible loads to be disconnected such as lights, compressors, air conditioners, pumps, fans and extractors, packaging machinery, shredders and others. The general purpose of maximum demand meter is to monitor and control the maximum power demand which also reduces the monthly electricity bill. By using this meter, the users do not have to worry about their electricity bill as it will be much less as compared to previous bill before installing the meter[4]. In order to reduce the overall consumption of electrical energy. The load problems can be overcome by control over the usage of electrical loads according to the load priorities with respect to time. By this load control approach we have two advantages: this reduces the burden on the supplier and also the need of purchasing electricity from the other states can be postponed[1].

## 2. DESIGN OF MAXIMUM DEMAND CONTROL

### 2.1 PERSONAL COMPUTER

A personal computer is a general-purpose, cost effective computer that is designed to be used by a single end-user. Every PC is dependent on microprocessor technology, which allows PC to set the entire central processing unit (CPU) on single chip. This PC is now used as a display unit for displaying the output of the MDC circuit.



Fig:2.1 personal computer

## 2.2 DRIVER RELAY

This is to obtain logical data from embedded controller and amplify the signals up to 60mA from 5mA. “ULN 2003” a darlington pair 7 pack transistor modules will be used for this. This chip contains seven NPN transistors inside which collects logical data and switching the relays with back EMF protection. This is the purpose of this chip as a driver relay



Fig: 2.2 driver relay

## 2.3 PIC MICROCONTROLLER

To perform the various operations and conversions required to switch, control and monitor the devices, processor is needed. The embedded controller selected for this project is “PIC16F877A” due to its various features such as high performance and Compatible to all computer language it is used in our project as a controller component. It consist of 5 I/O ports the ports are port A port B port C port D and port E. The ports A&E are for analog signal other ports are for digital signal.



Fig:2.3 pic microcontroller

## 2.4 RELAY

This is a electromagnetic alteration type of component .This is a electrically operated switch which creates galvanic isolation between two circuits. The objective of this component is to create isolation between embedded circuit and wireless circuit and used to trip the load when the load consume above the fixed limit.

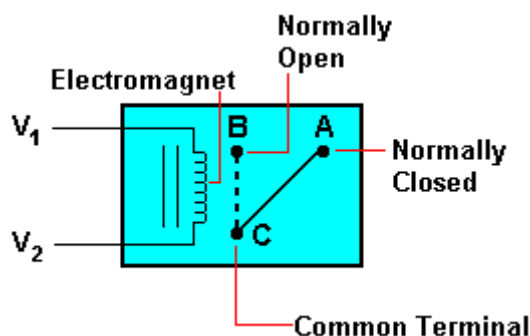

Fig: 2.4 relay

### 2.5 ANALOG SIGNAL PROCESSOR

The MC1458 is a high-performance, monolithic, dual operational amplifier intended for a wide range of analog applications. The high gain and wide range of operating voltages provide superior performance in integrator, summing amplifiers, and general feedback applications. This operational amplifier is used for converting the voltage in to current by using the shunt resistance.

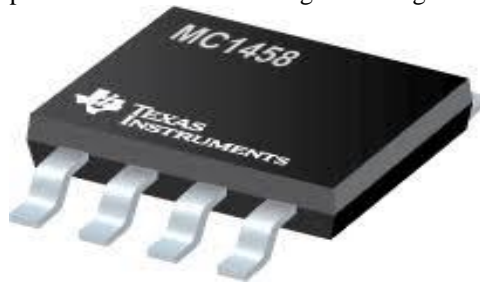

Fig: 2.5 dual operational amplifier

### 2.6 INSTRUMENTATION TRANSFORMER

Reduce high voltage and high current to a much lower value and provide a convenient way to safely monitor the actual electric current and voltage flowing in the transmission line. The output of instrumentation transformer is given to analog signal processor Instrument transformers are used for measurements at generating stations, transformer stations and transmission lines, in conjunction with ac measuring instruments Instrument transformers are classified into two types according to their use . They are:

1. POTENTIAL TRANSFORMERS 230V/6V
2. CURRENT TRANSFORMERS 5A/0.5A

### 2.7 LOAD

An electrical load is an electrical component or portion of a circuit that consumes (active) electric power. This is opposed to a power source, such as a battery or generator, which produces power. In electric power circuits examples of loads are appliances and lights. In our project we have used "BULB" as connected load.



Fig: 2.6 load

### 2.8 AUXILIARY SUPPLY

Auxiliary power is electric power that is provided by an alternate source and that serves as backup for the primary power source at the station main bus. An offline unit provides electrical isolation between the primary power source and the critical technical load whereas an online unit does not.

### 2.9 POTENTIAL TRANSFORMER

It is used to transform the high voltage of a power line to a lower value. since PT will be working with very high primary voltage, the insulation between the primary and secondary windings must be able to withstand large potential differences . Recent developments in the synthetic rubber industry have introduced the molded rubber potential transformer. The bushings are made of molded rubber, so that porcelain breakage is eliminated.

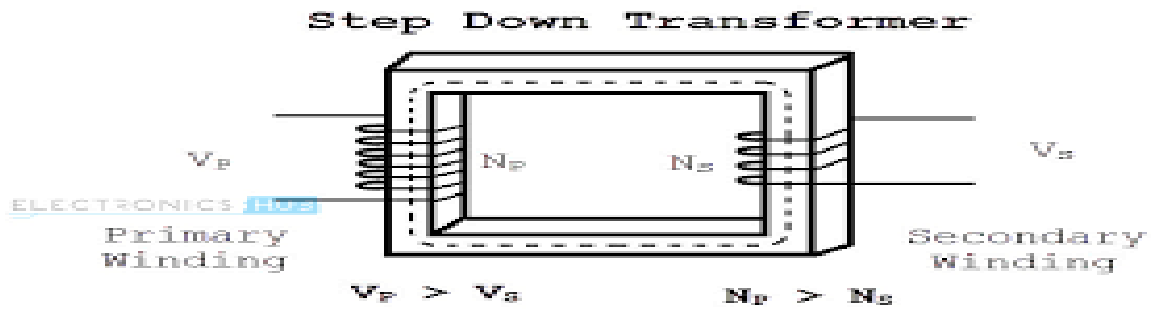

Fig: 2.7 potential transformer

### 2.10 CURRENT TRANSFORMER

The primary winding is a single conductor in the form of a heavy copper or brass bar running through the core of the transformer. The CT secondary winding is usually designed to deliver a secondary current of 0.5A. An 5A/0.5A the current transformer used in this project consist of a core with the secondary winding encased molded-rubber insulation,

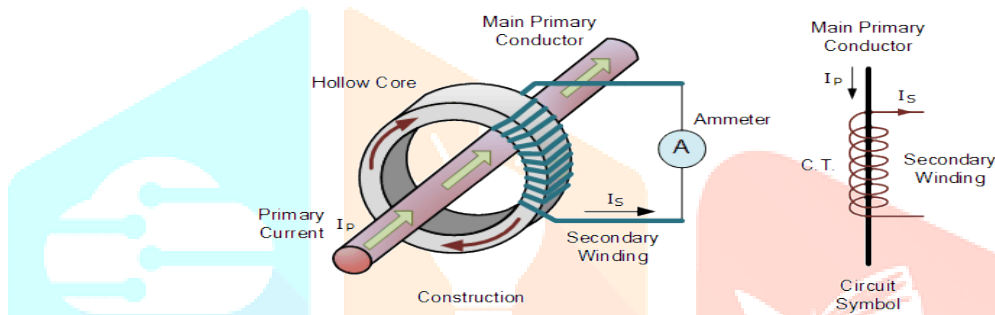

Fig: 2.8 current transformer

## 3. SOFTWARE DESCRIPTION

### 3.1 VISUAL BASIC STUDIO

- In Visual Basic 6.0, the “Visual “ part refers to the method used to create the *Graphical User Interface* (GUI). Rather than writing numerous lines of code to describe the appearance and location of interface elements, we simply add Pre built Objects in the required place on the screen.
- The “Basic” part refers to the BASIC (Beginners All- purpose Symbolic Instruction Code) language, a language used by more programmers than any other language in the History of Computing.

## 4. RESULTS AND DISCUSSION

The fully assembled Maximum Demand Controller is shown in figure



Fig:4.1snap shot of hardware

**OPERATING CONDITION**

The loads are under normal condition When they are not exceeding the fixed limit hence the relay are under OFF condition. The RY voltage, current, and power with respect time period are shown in the below figures

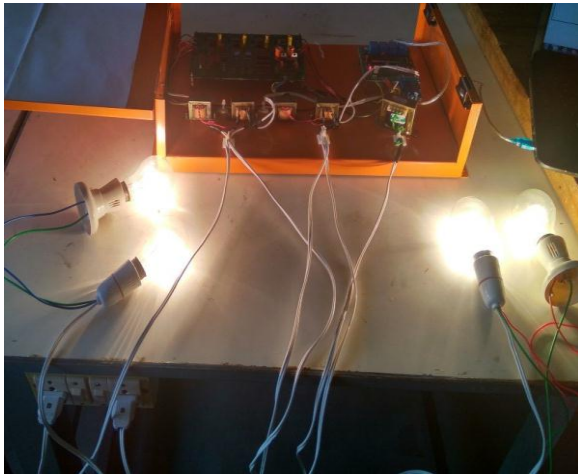

Fig: 4.2 operating condition

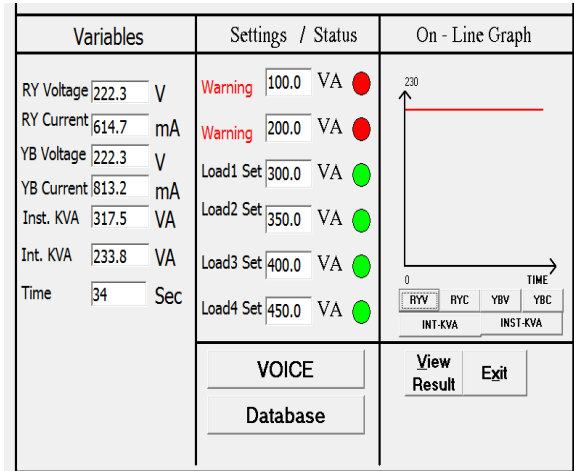

Fig:4.3 RY voltage

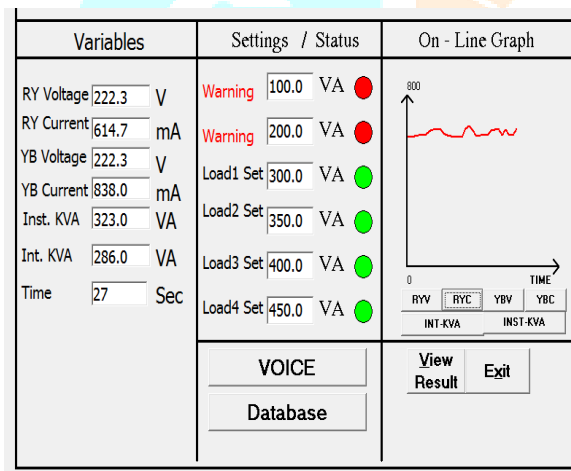

Fig: 4.4 RY current

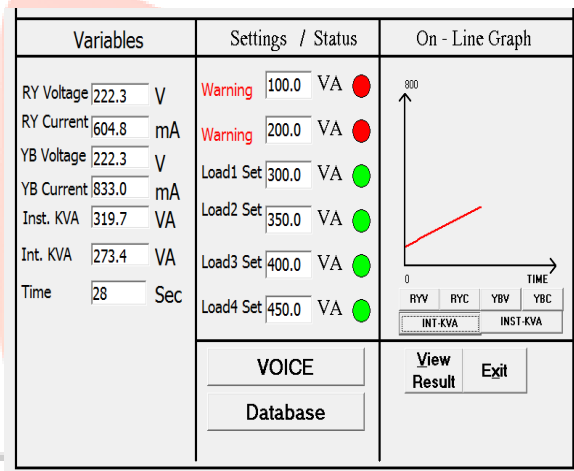

Fig: 4.5 RY power

**5.CONCLUSION**

In this project, when the load goes above the fixed value the load get tripped automatically indicates the consumption of energy is near the fixed rate. By using maximum demand controller the usage of energy is within the limit and avoiding the consumers from paying penalty. The data can also be recorded for the future analysis. The voice command is given when the load crosses the fixed rate is an additional advantage.

**REFERENCES**

- [1] Dr.Ravi Babu, P.Satya Krishna. "Design Of Smart Maximum Demand Controller for Peak Load Management for Domestic Loads –application of dsm tool", International journal on advance in computer logic, technology and sciences.
- [2] J Pauline Jothi Kiruba, N. Nandha, J.Regun Vincent Paul, E.Soundararajan,C.Tamil Selvi. "Management Of Maximum Power Demand with Generator Control Mechanism using 12C Protocol", Journal Of Engineering.
- [3] Apurva A. Bhagwat, Shraddha A. Bhagwat, Priyanka S, Deshmukh, yatin p. Bisne, Chandrakant L. Bhattar . "Maximum Demand Controller using Microcontroller AT89c51",ISRO Journal of electrical and electronics engineering
- [4] Supriti Dash Sharma, Rajeshwari Arelli, Ankit Dukre, Renuka Bhandarkar. "Management of Loads using Maximum Demand Meter for Commercial Sectot at Peak Load Demand Meter", International journal of engineering research and applications.
- [5] M.U.Bhadane, P.R.Rahatal, K.S.Taskar & A.S Jain. "Microcontroller Based Maximum Electricity Demand Controller", Journal of computer engineering.