

# MULTITASKING SMART HOME AUTOMATION

Dhananjay L. Ray, Chetan A. Rodke, Ganesh G. Zade, Wasim B. Ansari

ECE Department  
SSCET Bhadrawati, Chandrapur(MH)

**Abstract:** This project presents the smart design HAS (Home Automation System) with number of different future and advantages of wireless system with low cost. This system design to assist and provide support in order to fulfill the need of elderly and disabled person in home. This project also improves the living standard at home. The VOICE, GSM & IR switch modes are used to smartly control the appliances with low maintenance and acknowledgment or status of appliances is received by android application via mobile, tablet, or laptop. In this project we will also control the appliances through the any IR TV remote.

Real time existing switches status. The system intended to control electrical appliances as well as devices in the house with relatively low cost designs, user-friendly interfaces and ease of installation.

**Key Words:** Home Automation System (HAS), Bluetooth, GSM (Global System For Mobile), TSOP 1738, AVR Board, Relay Board, SMS, Voice, Remote Controls.

## 1. INTRODUCTION:

### (A). OVERVIEW:

The HAS concept has existed for many years. The smart home introduces the concept of the networking appliances and devices in the house. This project represent the great research opportunity in certain a new fields in engineering & computing. Smart home automation includes centralized control lighting, appliances, security locks, gate – door and others systems. To provide intelligent comfort, energy efficiency and security system. The home automation becomes need of future as well as nowadays in the world.

Due to the advancement of wireless technology there are several different types of connections are introduced such as GSM, WIFI, BLUETOOTH, IR and due to the electronics advancement cost of this project is acceptable to any kind of users. And also it's easy to install anywhere. Using android smart phone, tablet, IR remote we can control the all appliances with the real time need like via SMS, Voice or simple switching with handset of TV remote.

### (B). ADVANTAGES OF HAS SYSTEM

In recent years GSM, Bluetooth & IR remote sensor technology is more popular in wireless communication and the use of wireless technologies gives several advantages that could not be achieved using a wired network only.

1. Compact size: In this HAS system we are use the MEMS technology which is miniaturize the whole system in compact size because we add the 3 different receivers circuits in single chip.
2. Reduce cost: Because of compact size and microelectronics chips it reduces the whole cost of HAS system.
3. There is no need for extra training of that particular user who has to be use this system.
4. All the long as well as short distance controlling would be in your hands by using this smart HAS system.
5. This project can provide the facility of security based monitoring of all the appliances within the communication range through Bluetooth.
6. Reliable and fast response.

## 2. REVIEW LITERATURE:

[1] Sirsath N. S, Dhole P. S, Mohire N. P, Naik S. C & Ratnaparkhi N.S

The main concept of this Paper is to design and implement as well as control and monitor the system for smart home. Smart house system consists of many systems that controlled by Lab VIEW software as the main controlling system in this paper. Also, the smart house system was supported by remote control system as a sub controlling system. The system also is connected to the internet to monitor and control the house equipments from anywhere in the world using Lab VIEW.

[2] Basil Hamed: The concept of this paper is to provide a security using android phone and tab. This system uses a consolidation of a mobile phone application, handheld wireless remote, and PC based program to provide a means of user interface to the consumer.

[4] Basma M. Mohammad El-Basioni, Sherine M. Abd El- kader and Mahmoud Abdelmonim Fakhreldin : The main concept of this paper is to introduce a new design for smart home using wireless sensor network and biometric technology. The system employs the biometric in the authentication for home entrance which enhances home security as well as easiness of home entering

process. The structure of the system is described and the incorporated communications are analyzed, also estimation for the whole system cost is given which is something lacking in a lot of other smart home designs offers. WB-SH is designed to be capable of incorporating in a building automation system and it can be applied to offices, clinics, and other places. The paper ends with an imagination for the future of the smart home when employs the biometric technology in a larger and more comprehensive form the paper ends with an imagination for the future of the smart home when employs the biometric technology in a larger and more comprehensive form.

[3] Deepali Javale, Mohd. Mohsin, Shreerang Nandanwar This paper main objective is to assist physically challenged and old age peoples . It gives basic idea of how to control various home appliances and provide a security using Android phone/tab. The design consists of Android phone with home automation application, Arduino Mega ADK. User can interact with the android phone and send control signal to the Arduino ADK which in turn will control other embedded devices/sensors.

## 1. PROJECT IMPLEMENTATION

### (A). Proposed Home Automation System:

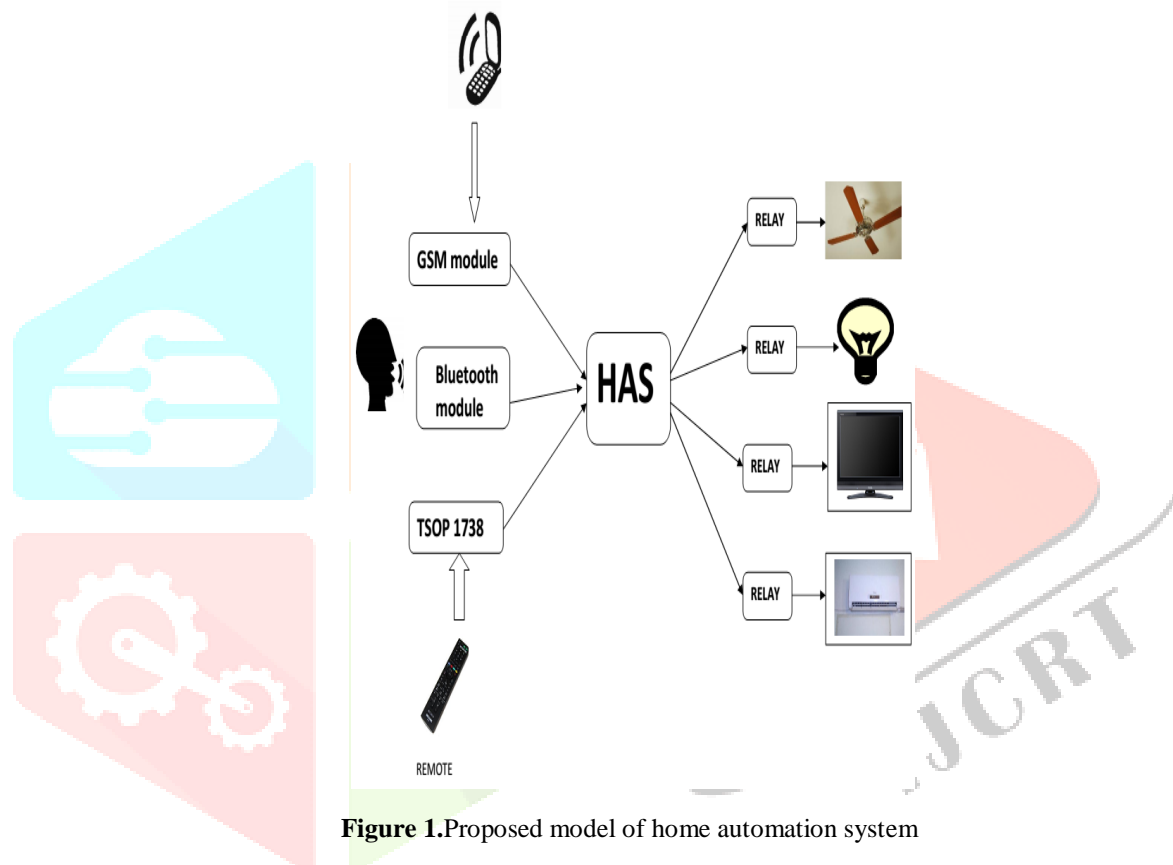

Figure 1. Proposed model of home automation system

The proposed model of home automation system is as shown in figure 1. The model consists of different module, sensor & actuators like GSM, Bluetooth, and TSOP 1738, relays and arduino board. When the connections is established it will start reading the parameters of sensor like S1,S2,S3 etc. the threshold level of required sensor module are set as t1,t2,t3 etc. the input of the system module is sent the signals depending on user selection it may be message, voice or through the IR remote. Then this command signal is received by receiver then analysis this signals if the respective signal is greater than particular threshold level then predefined relay is activated and particular. In the HAS system it is possible to easy to on/off by particular distance as well as over long distance by help of GSM technology. User can also start any appliances via message or remote and its simply off by voice command by the different commands user can on/off appliances at a time.

### (B). Home Automation System Functions:

The proposed HAS system has the capabilities by controlling the following components used by users in home:  
 Message via mobile phone.  
 Voice command via smart phone.  
 IR command using TV remote.

The HAS system can control the appliances

Fan on/off

Light on/off

TV on/off etc.

**(C). Proposed Home Automation System Functions:**

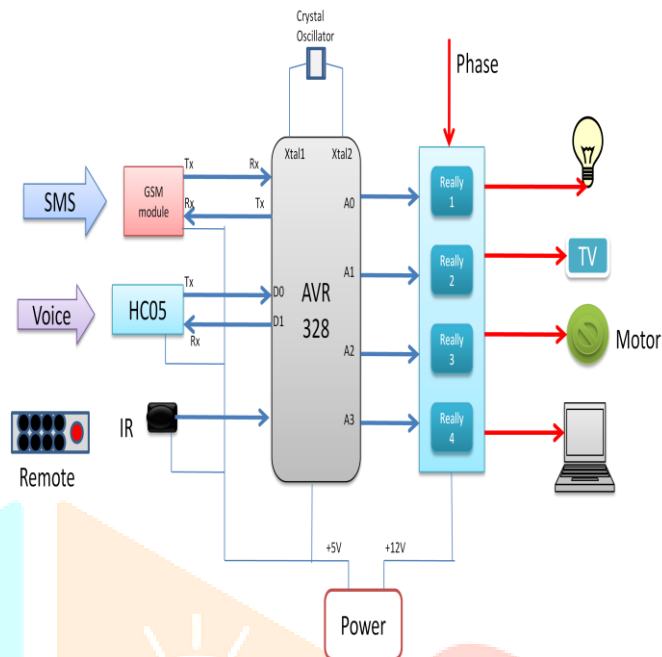

**(D). Implementation setup:**

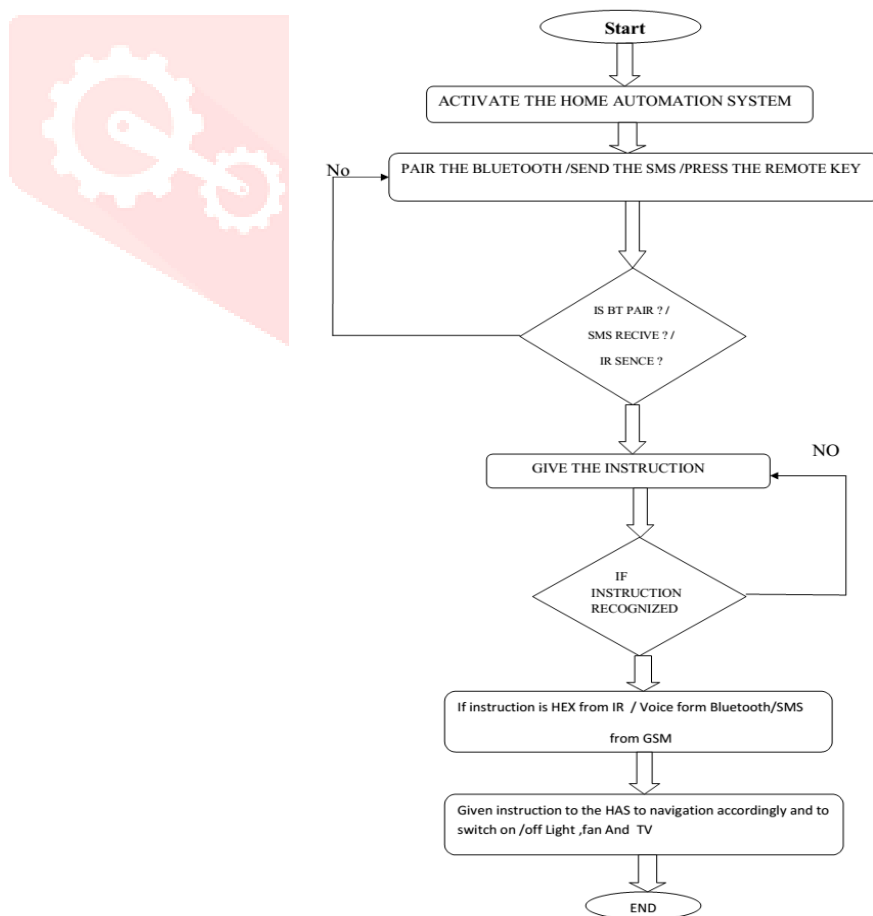

**(E). Working:**

Our Project is executed by particular sequence as shown in by flowchart further operation will be explain below.

First when the power supply is enable the HAS system is activated or ready to access the transmitted signal from transmitter by user command.

User have three different method have to the user send our command (voice Command) via Bluetooth. SMS command send via GSM & press the remote key depending on user convenience.

Now HAS system firs will check which command is send & depending on command or instruction system will provide execution signal toward particular appliances light ,fan ,TV etc. if ones command execute completely then HAS system operate in this sequence as user need.

**4. COMPONENTS:****(A). Atmega 328:**

The Atmel 8-bit AVR RISC-based microcontroller recombines 32 kB ISP flash memory with read-while-write capabilities, 1 kB EEPROM, 2 kB SRAM, 23 general purpose I/O lines, 32 general purpose working registers, three flexible timer/counters with compare modes, internal and external interrupts, serial programmable USART, a byte-oriented 2-wire serial interface, SPI serial port, 6-channel 10-bit A/D converter (8-channels in TQFP and QFN/MLF packages), programmable watchdog timer with internal oscillator, and five software selectable saving modes. The device operates between 1.8-5.5 volts. The device achieves throughput approaching 1 MIPS per MHz.

**Application:** As of 2013 the ATmega328 is commonly used in many projects and autonomous systems where a simple, low-powered, low-cost micro-controller is needed. Perhaps the most common implementation of this chip is on the popular Arduino development platform, namely the Arduino Uno and Arduino Nano models.

**(B). Bluetooth to serial port module HC-05:**

**Overview:** HC-05 module is an easy to use Bluetooth SPP (Serial Port Protocol) module, designed for transparent wireless serial connection setup.

Serial port Bluetooth module is fully qualified Bluetooth V2.0+EDR (Enhanced Data Rate) 3Mbps Modulation with complete 2.4GHz radio transceiver and Baseband It uses CSR Blue core 04-External single chip Bluetooth system with CMOS technology and with AFH (Adaptive Frequency Hopping Feature). It has the footprint as small as 12.7mmx27mm. Hope it will simplify your overall design/development cycle.

**(C). TSOP.1738**

**Description:** The TSOP17 – series are miniaturized receivers for infrared remote control systems. PIN diode and preamplifier are assembled on lead frame, the epoxy package is designed as IR filter. The demodulated output signal can directly be decoded by a microprocessor. TSOP17 is the standard IR remote control receiver series, supporting all major transmission codes.

**(D). GSM MODULE:**

GSM/GPRS module is used to establish communication between a computer and a GSM-GPRS system. Global System for Mobile communication (GSM) is an architecture used for mobile communication in most of the countries. Global Packet Radio Service (GPRS) is an extension of GSM that enables higher data transmission rate. GSM/GPRS module consists of a GSM/GPRS modem assembled together with power supply circuit and communication interfaces (like RS-232, USB, etc) for computer. GSM/GPRS MODEM is a class of wireless MODEM devices that are designed for communication of a computer with the GSM and GPRS network. It requires a SIM (Subscriber Identity Module) card just like mobile phones to activate communication with the network. Also they have IMEI (International Mobile Equipment Identity) number similar to mobile phones for their identification. A GSM/GPRS MODEM can perform the following operations:

1. Receive, send or delete SMS messages in a SIM.
2. Read, add, search phonebook entries of the SIM.
3. Make, Receive, or reject a voice call.

**5. FUTURE SCOPE**

1. Memory can be used to store the appliance status during power failure.
2. Appliance scheduler/timer can be implemented using RTC (Real Time Clock)
3. Can be changes to an IOT device using WIFI Connectivity
4. We can also use the voice recognition features for security purpose.

## 6. APPLICATION:

1. Its reliable for the Smart Digital Home
2. It's Also use for Agriculture
3. It's also Applicable in industrial Area for the smart Control

## 7. CONCLUSION:

Thus we have use the home automation using GSM, voice and remote controlled. We can seen in this project the changes of controlling strategy and controlled from long distance without any problem.

## REFERENCES

- [1] Sirsath N. S, Dhole P. S, Mohire N. P, Naik S. C & Ratnaparkhi N.S Department of Computer Engineering, 44, Vidyanagari, Parvati, Pune-411009, India University of Pune, "Home Automation using Cloud Network and Mobile Devices"
- [2]Deepali Javale, Mohd. Mohsin, Shreerang Nandanwar "Home Automation and Security System Using Android ADK" in International Journal of Electronics Communication and Computer Technology (IJECCCT) Volume 3 Issue 2 (March 2013)
- [3]Charith Perera, Student Member, IEEE, Arkady Zaslavsky, Member, IEEE, Peter Christen, and Dimitrios Georgakopoulos, Member, IEEE "Context Aware Computing for The Internet of Things: A Survey". IEEE COMMUNICATIONS SURVEYS & TUTORIAL
- [4] Charith Pereray, Arkady Zaslavskyy, Peter Christen\_ and Dimitrios Georgakopoulosy Research School of Computer Science, The Australian National University, Canberra, ACT 0200, Australia CSIRO ICT Center, Canberra, ACT 2601, Australia " CA4IOT: Context Awareness for Internet of Things"
- [5] Bill N. Schilit, Norman Adams, and Roy Want, "Context-Aware Computing Applications"
- [6] C.-H. Chen, C.-C. Gao, and J.-J. Chen, "Intelligent Home Energy Conservation System Based On WSN," presented at the International Conference on Electrical, Electronics and Civil Engineering, Pattaya, 2011.
- [7] R. Piyare and M. Tazil, "Bluetooth based HAS using cell phone," in Consumer Electronics (ISCE), 2011 IEEE 15th International Symposium on, 2011, pp. 192-195.
- [8] Wikipedia. (2012, 12th December). Home automation. Available: [http://en.wikipedia.org/wiki/Home\\_automation](http://en.wikipedia.org/wiki/Home_automation)
- [9]<http://www.smartcomputing.com/editorial/article.asp?article=articles%2F1995%2Fmar95%2Fpcn0323%2Fpcn0323.asp> retrieved 2010 09 02
- [10] Chan, M., Campo, E., Esteve, D., Fourniols, J.Y., "Smart homes-current features and future perspectives," Maturitas, vol. 64, issue 2, pp. 90-97, 2009
- [11] Das, S.R., Chita, S., Peterson, N., Shirazi, B.A., Bhadkamkar, M., "Home automation and security for mobile devices," IEEE PERCOM Workshops, pp. 141- 146, 2011