

# COMPARITIVE BEHAVIOR OF STRUCTURES UNDER SEISMIC EFFECT WITH DIFFERENT DIAGRIDS AND SHEAR WALL ARRANGEMENTS

IMRAN PASHA<sup>1</sup>, RAKSHITHA J<sup>2</sup>

<sup>1</sup>M.Tech Student, <sup>2</sup>Asst Professor

Department of Civil Engineering

The Oxford College Of Engineering, Bangalore, India

**Abstract-** The evolution of newly developed methods in the field of architecture and engineering tends to improve the constructional aspects of the structures. The structures to be constructed in the present era should differ itself from the structures build in the past, keeping in mind its strength and aesthetical behavior. For any high rise structure, its major concern is to withstand the lateral forces like wind or earthquake. Although a conventional structure almost rectify these happenings but the performances can be maximized by using a diagrid or shear wall configuration. The diagrid and the shear wall systems opposes the effect of lateral forces and also helps in minimizing the net cost of construction. The diagrids helps to counter the lateral forces acting on the structure by its angular arrangements at the periphery thus eliminating the columns at the exterior of the structure. The diagrids performances can also be increased by increasing the angles of the diagrids. The shear walls helps in countering off the net shear forces by positioning itself either at the edges, periphery or at the center of the structure. The analysis of the factors like story displacements, story shears, story drifts etc are carried out and compared for both the conventional and the above mentioned structural arrangements.

**Key words;** Seismic effect, Story displacement, Story shear, Story drift, Diagrids.

## 1. INTRODUCTION

### 1.1 General

Modernisation and the standards of living of the people in the present generation paved a way for the evolutionary methods in the building construction along with the feasibility requirements in the construction. A high raised structure provides the space for many more people by reducing the geometrical property of the land. But, although a high raised structure is advantageous in this manner, it is subjected to lateral forces, especially the seismic forces causing the lateral displacement, shears, drifts etc. Along with these, the cost of construction is also increased. In order to make the structure efficient and feasible, adaptations like diagrids and shear walls are used to the conventional structures.

### 1.2 Diagrid Entity

Diagrids are the inclined members bisecting each others at any specified angle structurally operates as a supporting unit instead of exterior vertical columns. The removal of exterior columns provides a space for the diagrids to monitor the behavior of the structure. The diagrids are placed by removing the outer columns. The diagrids also improves the beauty of the structure at reasonably lesser cost than that of a conventional structure. Diagrids resists the lateral loads coming onto the structure from its angular arrangements. Hence, due to this, the lateral displacement, story shear, story drift etc can be reduced efficiently.

### 1.3 Shear wall Entity

Shear walls are shear resisting walls which are fixed at the base and are projected till the height of the structure. Shear walls carry horizontal seismic forces downwards to the foundations. Thus, design of their foundations requires special foundations. If, the

Shear wall is an exterior wall, then it will also carry the wind load & then it should also be design to resist the wind load and this load also get transfer to the foundation of the shear wall.

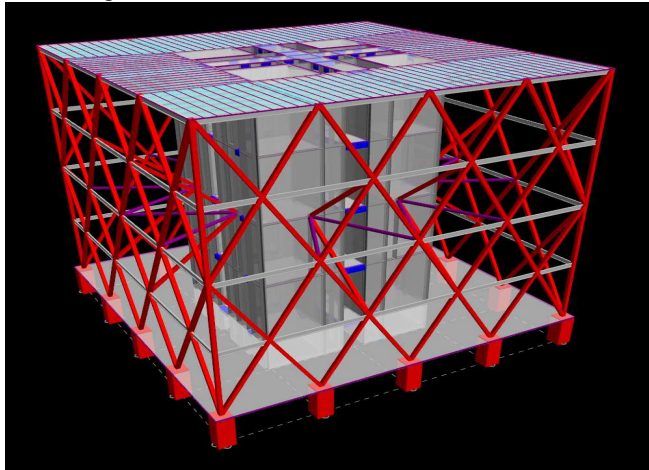

Fig-1: Diagrid compartment

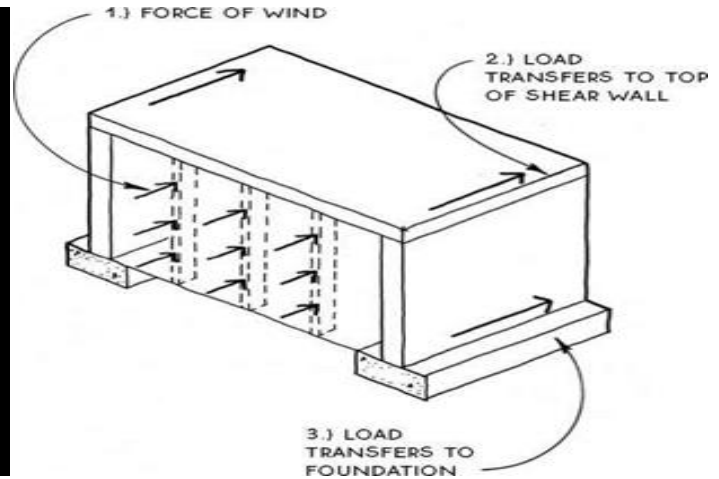

Fig-2: Action of a shear wall

### 2. OBJECTIVES

- Comparative study of to study the behaviour of structure with the different angles of diagrids and different shear wall placements onto a structure.
- To demonstrate the effects of displacements, drifts and shears from various diagrids and shear wall configurations.
- To examine the greatest stability and stiffness of the structure under extreme seismic conditions.
- To determine the efficient thickness of the shear wall to be considered.

### 3. METHODOLOGY

The modeling mainly comprises of three regular shaped structures with different angled diagrids subjected to one another. The details of the models are as follows:

- Model 1:** A 10 story building with square plan of 32m\*32m and an interval of 8m. The diagrid angle is 55°.
- Model 2:** A 15 story building with square plan of 20\*20m and an interval of 5m. The diagrid angle is 60°.
- Model 3:** A 20 story building with square plan of 30\*30m and an interval of 6m. The diagrid angle is 65°.

**Material properties:**

Concrete	M30
Reinforcement	Fe500

**Sectional properties:**

Columns	750*750mm
Beams	300*600mm
Diagrid	350*700mm, M30
Slabs	125mm
Shear wall	230mm

**Loadings:**

Dead load	2 KN/m <sup>2</sup>
Live load	3 KN/m <sup>2</sup>
Zone factor	0.24
Importance factor	1
Soil type	II
Response reduction factor	5

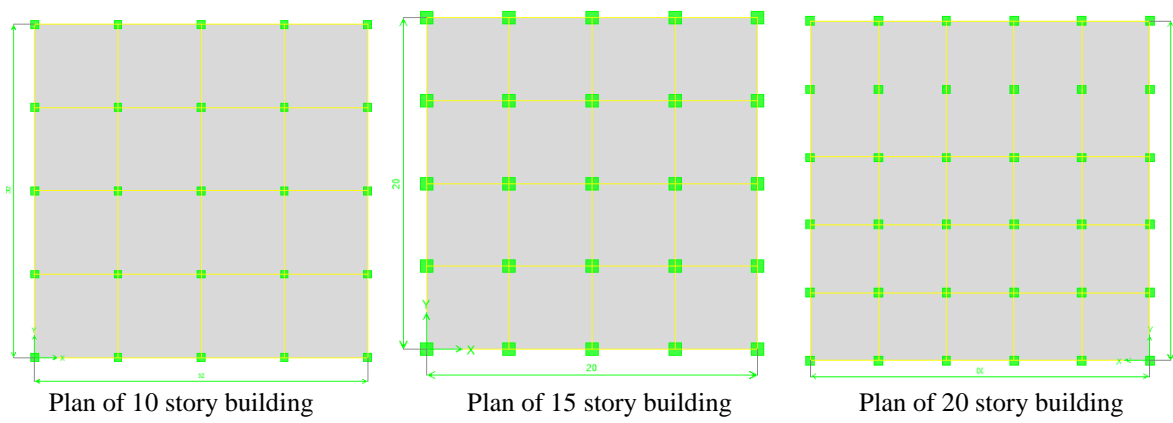
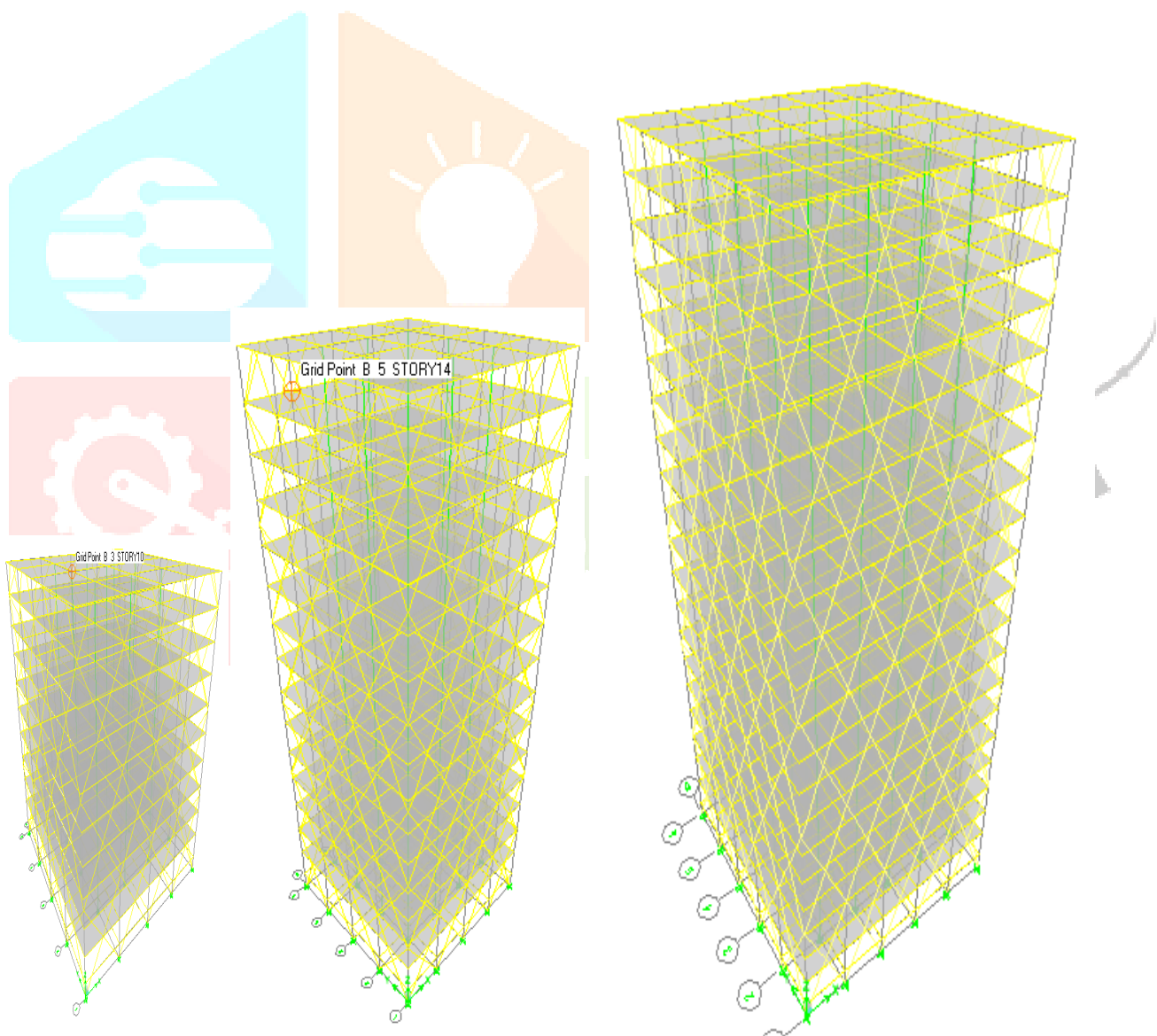

Fig-3



3D models of diagrid systems of 10, 15 and 20 storey respectively

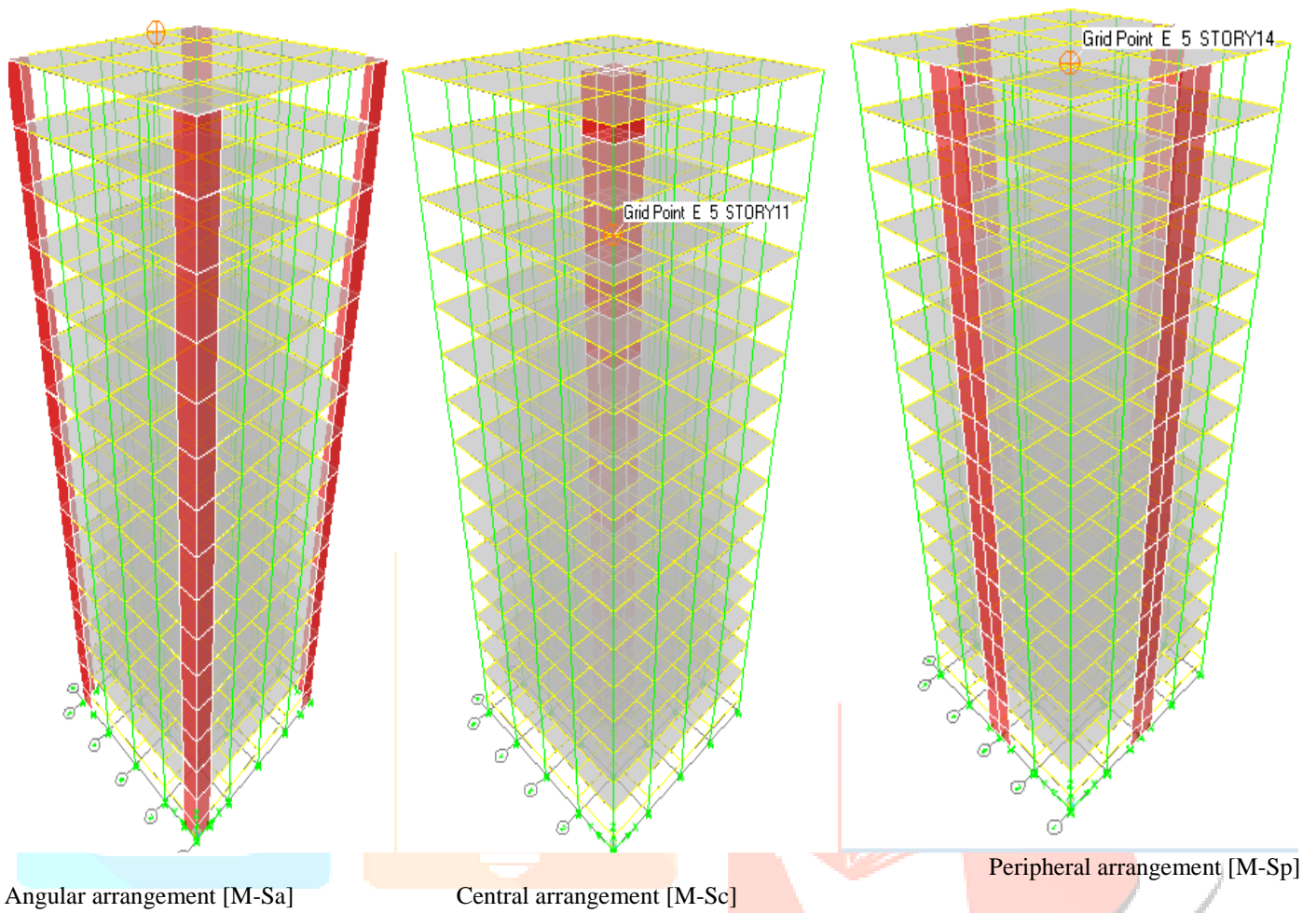

Fig-5 3D models of shear wall arrangements

#### 4. RESULTS AND DISCUSSION

In this part the static analysis results are tabulated. The parameters selected are lateral displacement, story drift and story shear.

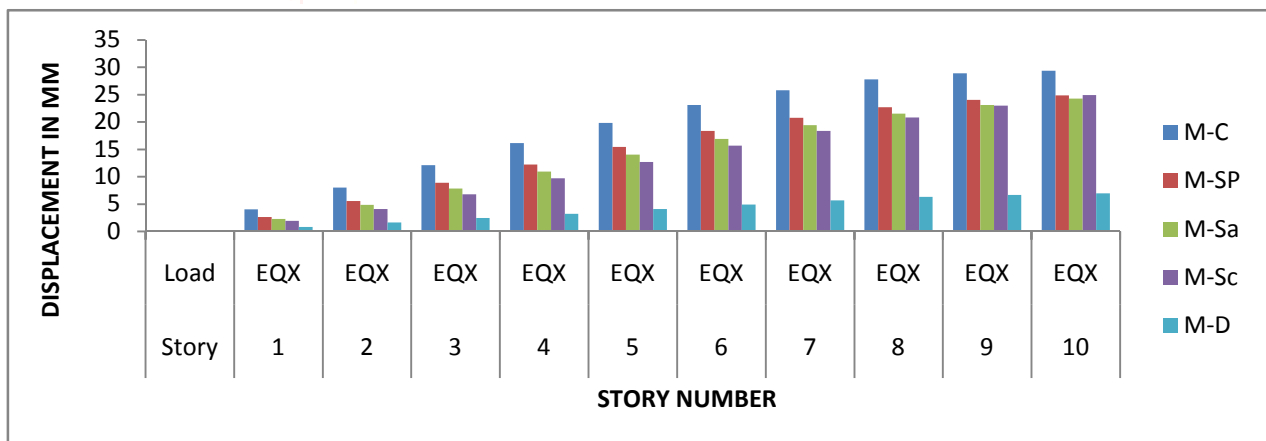

Fig-6 Max displacement of 10 story conventional, shear walls and diagrid arrangements

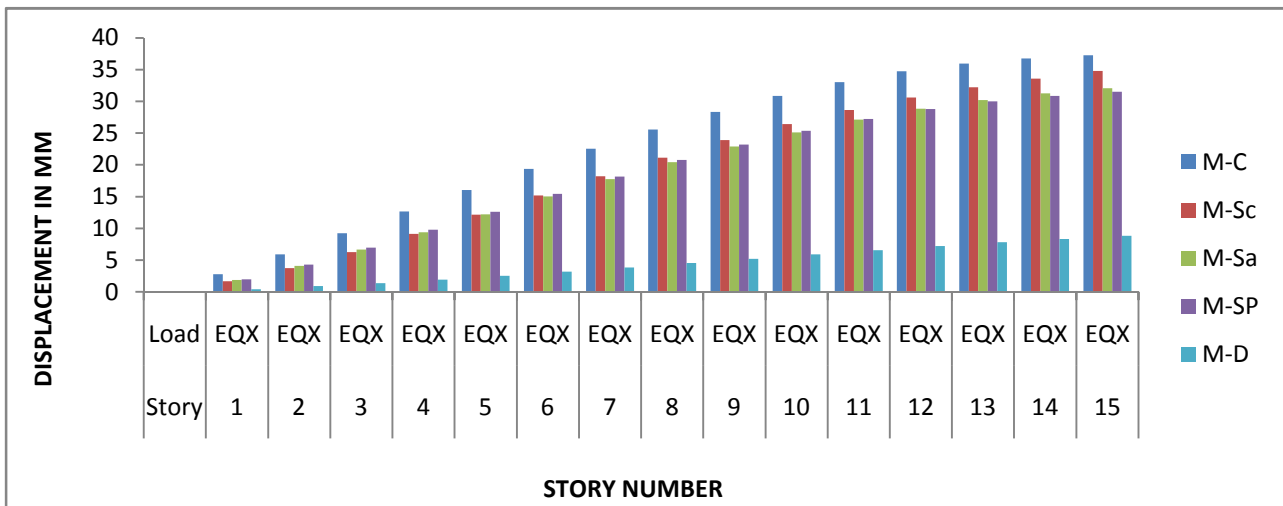

Fig-7 Max displacement of 15 story conventional, shear walls and diagrid arrangements

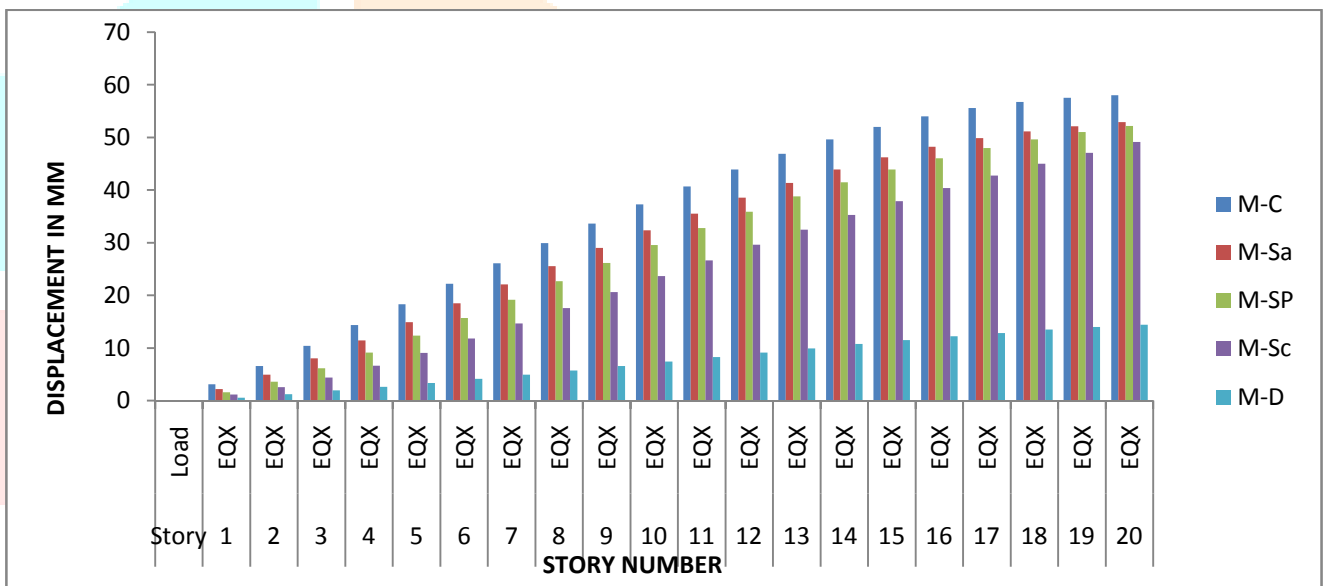

Fig-8 Max displacement of 20 story conventional, shear walls and diagrid arrangements



Fig-9 Max story shear of 10 story conventional, shear walls and diagrid arrangements

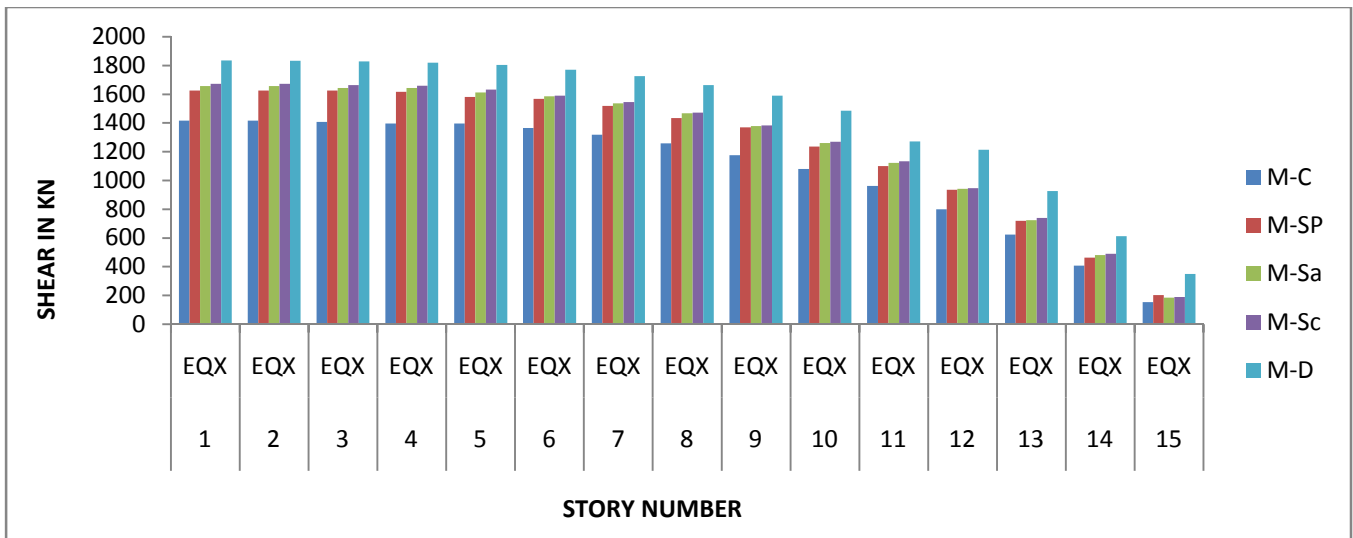

Fig-10 Max story shear of 15 story conventional, shear walls and diagrid arrangements

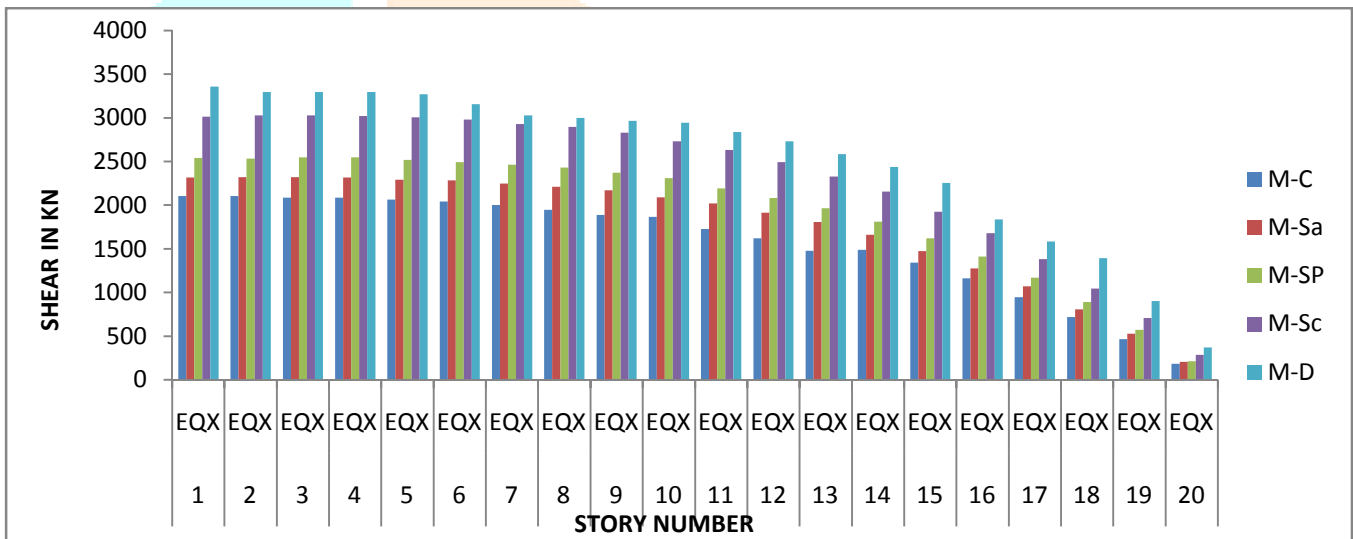

Fig-11 Max story shear of 20 story conventional, shear walls and diagrid arrangements

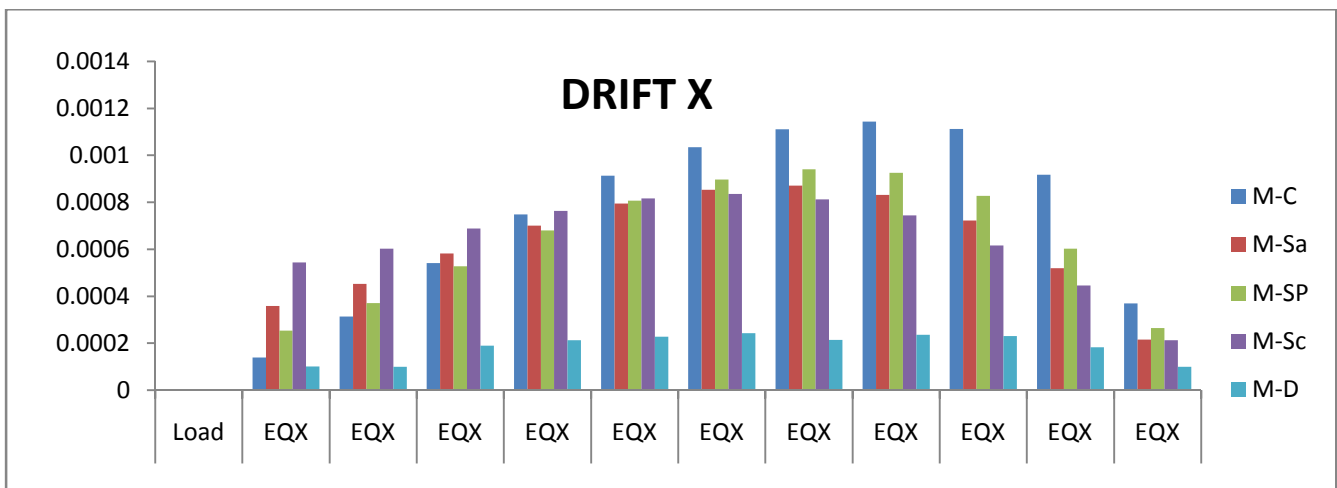

Fig-12 Max story drift of 10 story conventional, shear walls and diagrid arrangements

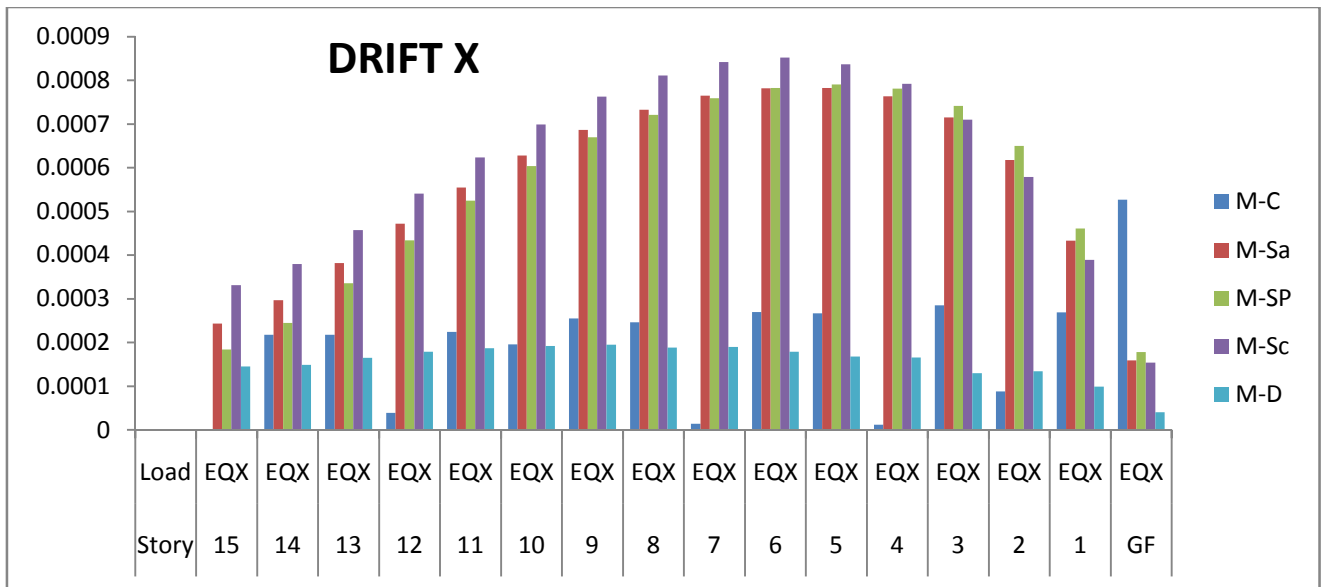

Fig-13 Max story drift of 15 story conventional, shear walls and diagrid arrangements

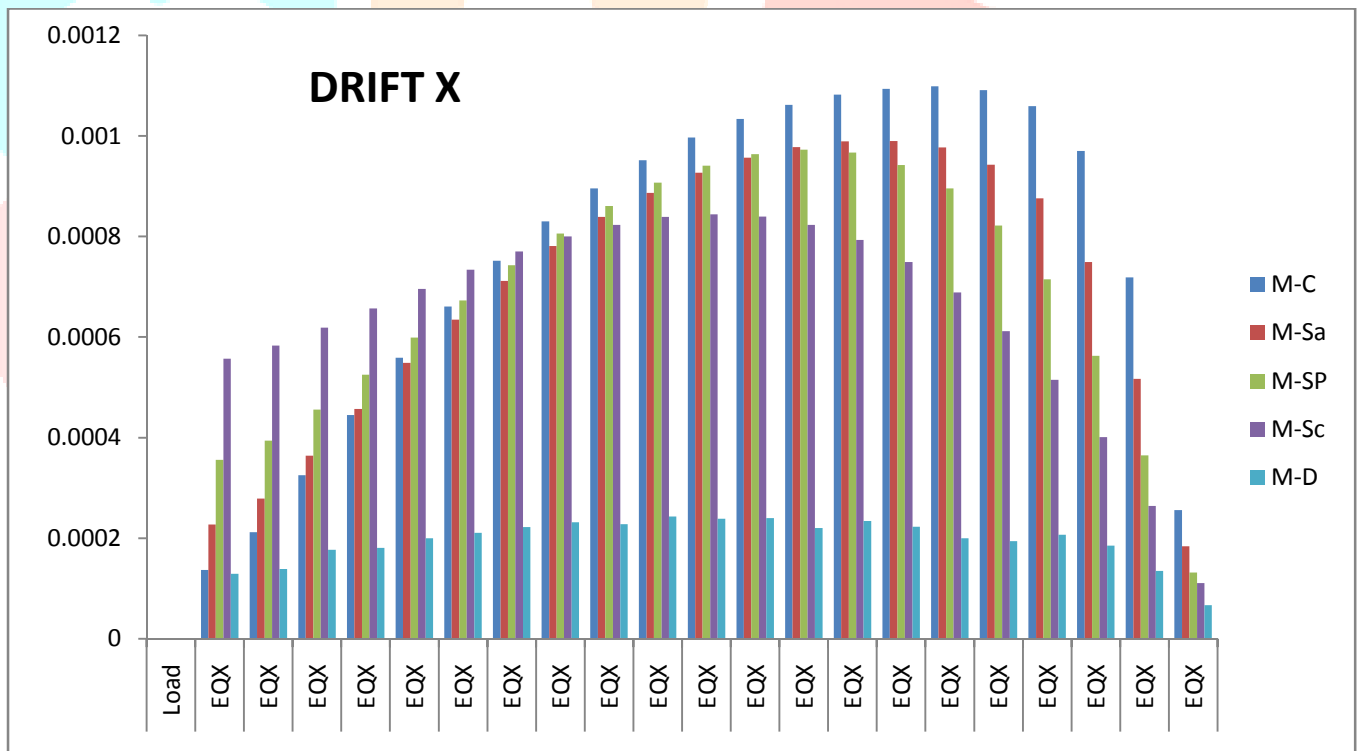

Fig-14 Max story drift of 20 story conventional, shear walls and diagrid arrangements

## 5. SUMMARY AND CONCLUSIONS

- From the above results we can conclude that the displacements, storey shears and story drifts vary from one structural configuration to other.
- We can conclude that maximum displacements, shear and drift occurs more at the conventional structure followed by the shear wall systems and minimum at the diagrid systems.
- Among all the shear wall configurations, shear walls placed at the angles proved out to be the best arrangement.
- As the angles of diagrids are increased more efficient are the results.
- *Results from the diagrid systems show that the reinforcement requirement in the structures will be less hence making it feasible against the others.*
- The diagrid arrangement shows that the structures are more flexible.

## 6. REFERENCES

- ⊙ [1] Kim J., Jun Y. and Lee Y.H., "Seismic Performance Evaluation of Diagrid System Buildings", 2nd Specialty Conference on Disaster Mitigation, Manitoba, June 2010.
- ⊙ [2] Moon K.S., "Material-Saving Design Strategies for Tall Building Structures", CTBUH 8th World Congress, Dubai, March 2008
- ⊙ [3] Leonard J., "Investigation of Shear Lag Effect in High-Rise Buildings with Diagrid System", M.S. thesis, Massachusetts Institute of Technology, 2007.
- ⊙ [4] Moon K.S., "Dynamic Interrelationship between Technology and Architecture in Tall Buildings", Ph.D. dissertation, Department of Architecture, Massachusetts Institute of Technology, 2005.

