



INTERNATIONAL JOURNAL OF CREATIVE RESEARCH THOUGHTS (IJCRT)

An International Open Access, Peer-reviewed, Refereed Journal

CONFLICT AVOIDANCE OF VEHICLE IN DEEP CURVES

Dr.S. Saraswathi¹, M. Annapoorna², M. Anukeerthana³, G. Anupriya⁴, K.Mohanapriya⁵

¹Associate Professor, Department of ECE, Mahendra Engineering College, Mahendhirapuri, Mallasamudram, Namakkaldt. -637 503.

^{2,3,4,5}Students (B.E., Electronics and Communication Engineering), Department of ECE, Mahendra Engineering College, Mahendhirapuri, Mallasamudram, Namakkaldt. -637 503.

ABSTRACT

The paper aims to decrease the number of accidents that occur on curved roadways. To do this, a warning LED light that illuminates as a vehicle approaches from the other side of the bend serves as a visual cue to the driver. The IR transmitter and receiver sensor, which is connected to the Arduino Uno microcontroller, is used to detect the vehicle. On the winding roads in the ghat portion, this might save thousands of lives. By implementing a new technique, they come up with a plan to prevent accidents after determining their causes and effects. Two IR sensors make up the new method, which alerts the vehicle on the opposite road. Accidents in the Ghats portion have not been avoided by me in any way. Therefore, a GSM module can be added, which will enable messages to be sent immediately to police stations and hospitals in the event that a driver has an accident in the Ghats region.

Keywords: Infrared sensors, Warning LED light, Ghats region, Convex mirror, GSM, Collision avoidance, Curve.

INTRODUCTION

Vehicles are essential to our daily life because they reduce the amount of time it takes for people to travel. According to article [2], several accidents happen on hilly roads as a result of other vehicles' lack of visibility, landslides, and unfavorable weather conditions. However, no precautions or measures to prevent them have been put in place. This leads to the loss of human life. Accidents are more likely to occur

when vehicles are travelling through hairpin curves. Drivers must exercise extra caution when driving through these sharp turns known as hairpins because there is little to no visibility between the vehicles. Additionally, there is a backlog of traffic because of disorderly movements. Every human being depends on vehicles for daily transportation. In addition, reckless driving and excessive speeds frequently result in accidents. Hilly locations present a riskier condition. The automobiles have no visibility because

of the hairpin curves. In order to prevent accidents at hairpin bends and preserve lives, the proposed solution will be helpful.

Accidents happen every day as a result of the rising usage of vehicles and transportation. Traffic law infractions, carelessness, and bad road conditions are the main causes of accidents. Vehicles travelling around these hairpin bends are especially susceptible to accidents due to a lack of communication and zero vision over the hairpin curves. As a result, Vehicles are therefore required to drive over hairpin turns with the utmost caution. In hilly places, these issues are of greatest importance. The suggested system uses a finely configured camera to identify the vehicles on one side of the curve, classifies the vehicles that follow into light or heavy vehicles, and then warns the cars on the other side of the curve using a display board. Information concerning the type of vehicle, the number of vehicles passing the curve, and the time it took the vehicle to complete the curve are all displayed on this seven-segment display board. Because of this, the suggested system gives drivers peace of mind while approaching vehicles on deep curves and makes sure they are aware of the type of vehicle that would be approaching. The suggested system lessens traffic congestion and accidents on hairpin bends.

In their daily lives, all people rely on transportation. A significant portion of accidents are also caused by speeding and reckless driving. The situation is considerably hazardous in locations with hills. Automobiles have no visibility because of the hairpin turns. In addition to reducing traffic congestion, the suggested technique avoids accidents on hairpin turns. Vehicles can effortlessly navigate the hairpin corners because to the real-time solution it offers. The Internet of Things (IOT) is a modern technology that has positively changed every aspect of our life. These technologies can be applied in a variety of settings to prevent accidents on roadways; ghat portions are where they are most commonly used. The roadways must be capable of coping with active changes in vehicle models. Mountain roads, tight turns, and hairpin bends are only a few of the hazardous curves and roads in the world. The drawback of these hairpin curves is that they make it difficult for drivers to

notice oncoming traffic or objects in their path. High speeds make the vehicle difficult to manage, and there is a chance that it could crash. Notifying drivers of approaching obstacles or vehicles is the answer to this issue. For this purpose, convex mirrors or horns are typically utilized, however this is incorrect. In order to prevent these issues on winding routes or hairpin bends, A sensor-based accident prevention system is what we're introducing. For example, before the curve, we will keep two IR sensors on one side of the road, and after the bend, we will keep an LED light on the other side.

LITERATURE SURVEY

The most crucial stage of the software development process is a literature review. It's important to assess the company's strength, the economics, and the time element before building the tool. The next steps are to decide which operating systems and programming languages are required for the project's development once these requirements have been met. The folks require outside assistance before they can build the initiative. You can find this outside assistance in books or online. The aforementioned factors are taken into account before building the proposal for the proposed system.

K.P. Sreevishakh, Prof.S.P. Dhanure [3] presented "Automotive Crash Insight using AMR Sensor System," The Unit was created to avoid a collision-based accident. The Arduino microcontroller, which handles all of the system's essential functions, is the "heart" of the unit. Additionally, it will be covered in the sections that follow. This system will gather data from the Ultrasonic transceiver and send it to the controller via the Wi-Fi router as a result.

S. Rakul,S. Ravia and K.N. Thirukkuralakani [2] presented "Implementation of Vehicle Mishap Averting System Using Arduino Microcontroller." By avoiding collisions, the device is intended to prevent accidents. An Arduino microcontroller, which handles all of the crucial functions of the system, serves as its "heart." Additionally, it will be covered in the parts that follow. This system will gather data from the ultrasonic transceiver and send it to the controller

over the Wi-Fi router in response. The vehicle information will be displayed to users via the buzzer signal, light-emitting display, and liquid crystal display. The system's main objective is to avoid collisions when two or more vehicles turn at the same time on a U-bend.

A. Rajakumaran, S. Vijay, and Lorate Shiny [1] presented When a road travels up or down a steep hill, hairpin turns are frequently created to allow the route to traverse mostly across the slope with relatively modest steepness, and they are frequently arranged in a zigzag pattern. Because of the sharpness of the turn, highways with recurring hairpin turns make climbing and descending hilly terrain easier and safer than direct, steep climbs and descents, but at the expense of longer travel durations and typically lower speed restrictions. In comparison to highways with tunnels, this type of route is usually typically less expensive to develop and maintain. When the terrain is exceedingly steep, hairpin turns are used. There will be a maximum gradient that a car or truck can travel on roads. In the image above, the zigzag portion reduces the grade, or steepness, of the road. You might have found yourself zigzagging back and forth across the road to climb a steep slope while riding a bike. Here, the same idea holds true.

There are standards for the radius of a curve when planning a road, mostly dependent on the design speed.

One of the most difficult activities in the hills is driving. Drivers must always be cautious while operating a vehicle in these regions. One of the main reasons for accidents in hilly places is that the driver does not see the car coming from the other side when the road is curved or has hairpin bends. Mountains have many twists and hairpin turns. The highway is a well-liked mode of transportation in these places. The frequency of accidents and fatalities is increasing rapidly in hilly terrain. It will be challenging to spot vehicles coming from the opposite direction because the roads in this region almost probably have twists and abrupt curves.

An LED display board alerts the vehicles on the opposite side of the curve when a vehicle is present on one side of the curve, classifies the following vehicle as light or heavy, and detects the existence of the vehicle using a camera. In order to warn the driver of an approaching opposing vehicle, our specifically designed LED display board includes information such as vehicle type and traffic signals. In order to reduce traffic congestion, our guiding principle is that a vehicle can easily pass through a hairpin curve as long as the driver is aware of the type of vehicle that will be approaching it—either a light vehicle or a heavy vehicle—so that they can gauge the distance at which the other vehicle can pass the curve. This gives the driver additional self-assurance when navigating hairpin curves.

Notifying the driver of an automobile that is coming from the other direction to do this, a vehicle approaching from one end of the curve triggers an ultrasonic sensor on one side of the road before the curve, and the LED light on the opposite side illuminates. By focusing on the LED light on/off indicator, the motorist can become more attentive and reduce speed.

Keeping people safe on the roads is one of the main objectives when building a help system. Nowadays, it is important for everyone to be certain that their travels will be secure. In 95% of all fatal accidents, human error is to blame. As a result, constructing a precise support system can reduce the accident rate. vehicle-to-hub as computer technology advances, communication is growing in popularity. The protection of a collision avoidance system.

METHODS

The suggested method helps the vehicle approaching from the opposite direction by detecting the vehicles on one side of the hairpin. The suggested system's objective is to categorize various vehicles travelling through one direction of the hairpin road and alert vehicles travelling in the other way of the hairpin via a display board. The category of the vehicle, the

number of vehicles in the curve, and the time it takes to pass the vehicle are all listed on this display board.

activated in the event of a system breakdown, alerting the maintenance division.

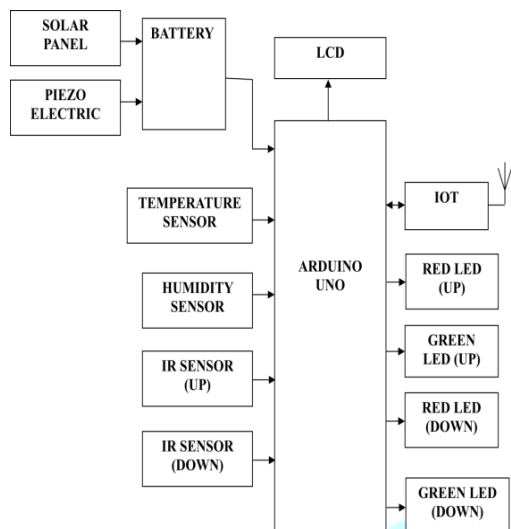

Fig 1: Block Diagram for Proposed System

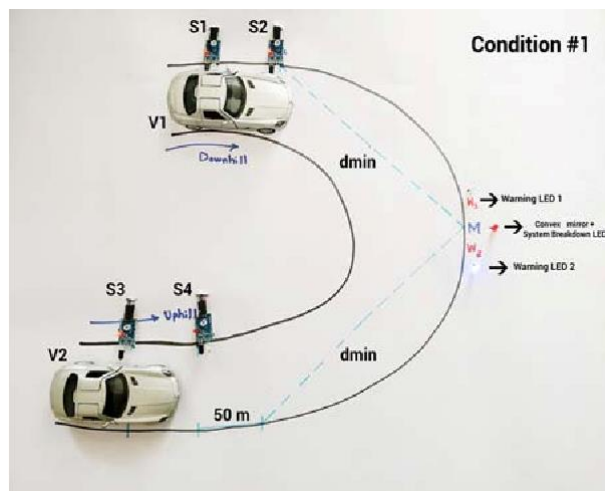

Fig 2: DEEP CURVES

Vehicle-to-hub Getting it can be made easier by communication. Car-to-car communication systems are primarily designed for safety and crash avoidance. Automobile-to-Hub communication This technology isn't designed specifically for a certain vehicle or maker. This may be used in any car with a little adjustment. The technology has been designed in a way that allows a conventional automobile driver to use it. One of humanity's greatest economic achievements is the automobile. They tragically had a high accident rate in the previous century and frequently became victims while travelling. Sensors track each vehicle's position in relation to the hairpin turn to decide which ones need to move first. Information transmitted between vehicles is recorded by the system. Through an algorithm-based visual display, the vehicle receives the choice regarding speed and distance. Architectures for both the hardware and software have been developed [4].

In [5] contains a series of ultrasonic sensors and installs warning lights and a convex mirror by the side of the road. The sensors, which are mutually exclusive, are connected via wires. Based on sensor data, the priority algorithm automatically restricts vehicle driving at the hairpin curve and issues the proper notifications when detection is found. For a variety of cases, the proper alert is triggered, giving the vehicle's movement priority. A warning LED is

In [3] contains to reduce the risk involved in driving through an area of terrain with sharp bends and hairpin twists. The ultrasonic sensor detects the vehicle approaching the bend and warns it to the opposite side of the bend or curve; it gives the driver approaching the hairpin bend or curve from the opposite side three levels of LED warnings. It also detects the vehicle's speed, and if the speed is too high, a buzzer will alert the drivers. These warnings will instruct drivers to slow down their vehicles. The main objective of the proposed system is to lower fatality rates in mountainous locations by avoiding accidents for both drivers and passengers. This technology makes it possible to analyze the number of uphill and downhill autos in hill stations by storing data in the cloud. The data analysis is seen online through a web application. The web tool can be used as a traffic pattern analyst by people who desire to go that way.

RESULT ANALYSIS

The work is designed to avoid collision-related accidents. This idea suggests employing sensors to detect obstacles within a 10-meter radius of the vehicle in order to prevent accidents and give safety-measuring processes in hairpin curves. A vehicle will automatically sense the signal if it is 10 metres from

the curve, at which point the sensor will sound a buzzer and an LED light to alert drivers travelling in the other way. Two Ultrasonic sensors are utilized, and they are positioned on either side of the hairpin turn. A sensor, S1, is installed by the side of the portion of the road that is uphill, and a second sensor, S2, is similarly placed by the side of the portion of the road that is downward. The sensors are wired together and connected to the ESP8266. The position of the vehicles on either side of the bend is determined using sensor output, and this information is sent as an input to the NodeMCU. In order to intelligently control vehicle movement at the bend, the NodeMCU, which runs on a 5V power source, runs and activates the warning LEDs (L1 in downhill and L2 in uphill conditions). At either side of the bend in a hairpin, there are warning LEDs and a buzzer.

The experiment begins with a sensor that detects the vehicle using an IR sensor. This work involves blinking to warn the driver. The ability to relay data observed from the opposite side of the road allows the collision avoidance in a hairpin bend. The system may warn the driver using LEDs and is fully integrated. Using their IR sensors, this system aids in the detection of the vehicles. Information on the vehicles in the Ghats section that are approaching from the other side is provided by this system. When the driver can't see the vehicle on the other side of the road due to the Ghats section's lengthy turns, this approach is helpful. Consequently, the system gives the user safety and security.

Infrared sensors are being used as proximity sensors and they can be passive or active. These sensors pick up energy emitted by objects in the field of vision without using an infrared source. The infrared source and the infrared detector are the two components that make up active infrared sensors. An infrared laser diode is one type of infrared source. Both photodiodes and phototransistors are used as infrared detectors. The infrared detector receives the energy that the infrared source emitted after it was reflected by a surface. The two components of an IR sensor, an IR LED and an IR photodiode, are collectively referred to as a "photo-coupler" or "opto-coupler." Radiation from the IR transmitter strikes the target and part of it bounces back to the IR receiver. The sensor's output is

determined based on the IR receiver's ability to receive signals with a certain amount of force.

CONCLUSION

India has the most traffic accidents in the entire world. Road accidents are generally brought on by driving at excessive speeds or failing to look for other vehicles coming from the other direction, especially while negotiating sharp curves. For the driver to easily observe a vehicle approaching from the opposite direction, convex mirrors are utilised in the existing system at curves. This system functions fine during the day but fails miserably at night. The suggested method makes advantage of sensors at hairpin turns, which function incredibly well at night. We will be able to remedy the issue by placing the sensors on either side of the curves. The sensor sends a signal that looks like this if the vehicle is 10 metres from the bend. The employment of sensors in this strategy, specifically at the deep curves, allows us to reduce the number of accidents. When the accident rate is reduced, people's wellbeing is improved.

REFERENCES

- [1] Lorate Shiny,Rajakumaran, S.Vijay (2019) are proposed "Vehicle Control System with AccidentPrevention by Using IR Transceiver"Vol. 4, Issue 6.
- [2] R.S. Rakul, S. Ravia and K.N. Thirukkuralkani(2016) proposed a paper on "Implementation of Vehicle Mishap Averting System Using Arduino Microcontroller"Vol. 5 Issue 04. April.
- [3] K.P. Sreevishakh, Prof.S.P. Dhanure,(2015) "Automotive Crash Insight using AMR Sensor System," International Journal of Advanced Research in Computer and Communication Engineering, Vol. 4, Issue 5.May.
- [4] S.P. Bhumkar, V.V. Deotare and R.V. Babar (2012) published a paper on "Accident Avoidance and Detection on Highways" Vol 3, Issue 2. April.

[5] S. Uvaraja and V. Raghav Prashanth, (2012)
“Advanced Pre-Warning System (Railways),”
IACSIT International Journal of Engineering and
Technology, Vol. 4, no. 2.

