



# INTERNATIONAL JOURNAL OF CREATIVE RESEARCH THOUGHTS (IJCRT)

An International Open Access, Peer-reviewed, Refereed Journal

## Object Tracker and Follower Robot using Raspberry Pi

Dr. Sameru Sharma, Dr.Ajay Abrol, Sumeer Khajuria, Swardhani Sharma, Mehak Gupta

Department of Electronics & Communication, GCET, Jammu, J&K, India

*Abstract- Intelligence in decision making in robotics is becoming essential as robots are designed and manufactured for various applications. In this paper, proposed Object Tracker and Follower Robot addresses the functioning of monitoring an object from its visuals and picture. Image processing follows autonomous robot driving guided by using images captured with the help of camera. The working of robot and it's controls are handled by a Raspberry Pi processor board. The attached camera on the device takes pictures of the front of the robot to which it is attached. The robot is able to autonomously decide where it needs to go by following the movement of incoming photos. The Open CV is applied using Python code.*

*Keywords: Raspberrypi, Camera, Image processing, Python, Open CV, Robot*

### 1. INTRODUCTION

Robotic vision systems and artificial intelligence both rely heavily on object detection. The distance, motion of the object, position, picture intensity are essential for image detection. Images once captured can be decoded using the above properties of the pictures. Detection of objects is applied in car parking systems, traffic control, medical, health care, various engineering fields. It is essential for applications requiring surveillance, autonomous vehicle steering, intelligent object tracking, etc. Effective image processing from a vision sensor and obstacle avoidances from distance sensors need to be processed efficiently [1]. In this work a vision-based robot system is studied that includes a nonholonomic robot with a tilt camera working on the concepts of geometry and motion dynamics [2]. The automation in detection and tracking is a fundamental task in aerial security designs [3]. Common technologies for UAV detection include visible-band and thermal infrared imaging, radio .

### II. Methodology

The adopted approach covers object detection To capture images, a camera is used in this work. The camera serves as the robot's eye. Capturing images and it's interpretation is crucial for the developing a reliable and effective vision-based robot. The work in this work is specifically divided into three parts, which include the robot's steering mechanism, an

algorithm for object monitoring, and picture processing. Machine vision finds applications for locating, measuring, inspecting and identification [4]. Due to the complexity and variety of applications for robots, designing mechanical models and programming for them is challenging. This paper outlines an effort to create simple, effective Robot and development of algorithms. This robot is far more affordable, lightweight, and simpler than current robots.

Tracking a moving object is to infer a few important characteristics from the sensor data, such as pose, velocity, acceleration, shape, and size. It has received a great deal of research and is itself a field of study. Additionally, the important methods for carrying out the monitoring significantly depend on the specific application.

### III. DESCRIPTION

The Raspberry Pi Kit, Pi Camera, Motor Driver, which can operate two motors, and Battery, which provides power supply, are mounted on a chassis. Because the Raspberry Pi has the processing ability to handle image processing software and give results in real time, it is being chosen as the project's main board. The GPIO pins, which can operate motors based on the outcome of processing, is one of its advantages. Also, it is a low power computer that can operate for many hours on a regular battery.

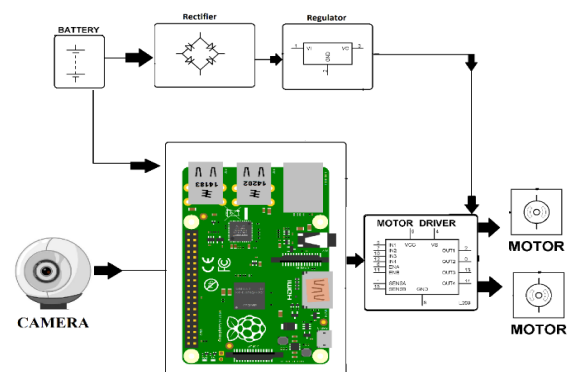

Figure 1: Block Diagram of Object Tracker and Follower Robot

Pi camera, which is mounted on the front part of the chassis of robot and linked to the Raspberry Pi with a RMC connector, continuously records photos or videos. Raspberry pi is a single chip computer that can perform various tasks and can communicate with devices like PC, Televisions, etc [7]. The design calculates distances of near by objects from a distance from user and solutions in real time is provided to manoeuvre safety by providing auditory input [8]. An underwater vehicle rover tracks pipelines and detect the fault in case it occurs . The kit of Raspberry pi gets the image taken from the pi camera and executes the python code. After the execution is complete, signals are produced in the Python code and sent to the robot via the kit. Robot effectively follows and detects objects. Robot will recognise an object with a particular shape or colour and track it by moving forward, backward, and left to right in accordance with the motion of the object.

#### IV. HARDWARE REQUIREMENT

1. The Raspberry Pi is economical and it is a computer of size similar to the credit card that connects to a monitor of computer or TV and makes use of a regular mouse and keyboard. Individuals of various ages can acquire programming and computing knowledge in languages such as Python and Scratch with the assistance of this dependable tiny device. It can do everything a desktop of computer can do, which include browsing the internet and watching high-definition video, as well as producing word processing documents, playing games and spreadsheets.

2. The Pi camera module is a tiny, portable camera that works well with Raspberry Pi. To communicate with the Raspberry Pi, it employs the standard MIPI camera serial interface. It is commonly used in machine learning, surveillance projects and image processing. As the camera's payload is so small, it is extensively used in surveillance drones.

3. Motor Driver (L293D)-The L293D is the dual H-bridge motor driver integrated circuit (IC).

Features & Specifications of L293D Dual H- Bridge Motor Driver IC:-

- Featuring Unit rode L293 and L293D
- Wide Supply-Voltage Range: 4.5 V to 36 V
- Separate Input-Logic Supply
- Internal ESD Protection
- Thermal Shutdown
- High-Noise-Immunity Inputs
- Output Current 1 A Per Channel (600 mA for L293D)
- Peak Output Current 2 A Per Channel (1.2 A for L293D)
- Output Clamp Diodes for Inductive Transient Suppression (L293D)

Motor drivers serve as current amplifiers because they transform a low-current control signal from resberry pi pins to a higher-current signal. This signal with a greater current level runs the motors. Two DC motors can run at the same time in both forward and reverse directions with greater speed due to amplified current in its standard mode of operation.

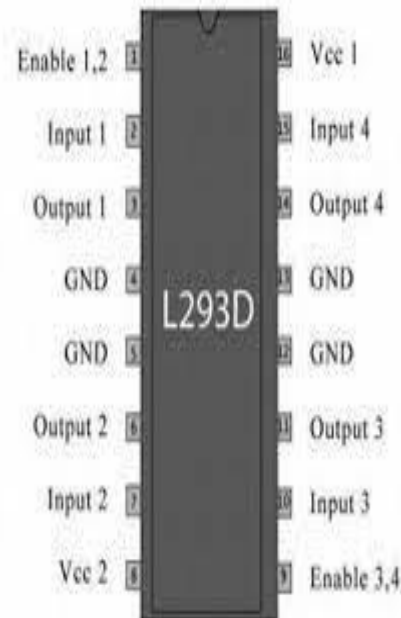

**Figure 2:**  
**Pin**  
**Diagram**  
**of L293D**  
**Moto**  
**driver**

4. DC Motor-A direct current (DC) motor is an electric motor that

employs direct current. An electric motor's functioning is based on basic electromagnetism. A current-carrying conductor generates a magnetic field; when that conductor is placed in an external magnetic field, it encounters a force that is inversely proportional to the current of the conductor and the strength of the externally applied magnetic field. This device changes electrical energy into mechanical energy.

5. Battery-A rechargeable battery is used in this project; it is a type of energy storage that may be recharged by passing DC current through its terminals after it has been discharged. Multiple uses of a cell are possible with rechargeable batteries, which reduces waste and, in general, serves as an excellent long-term investment in terms of the amount invested for device usage period

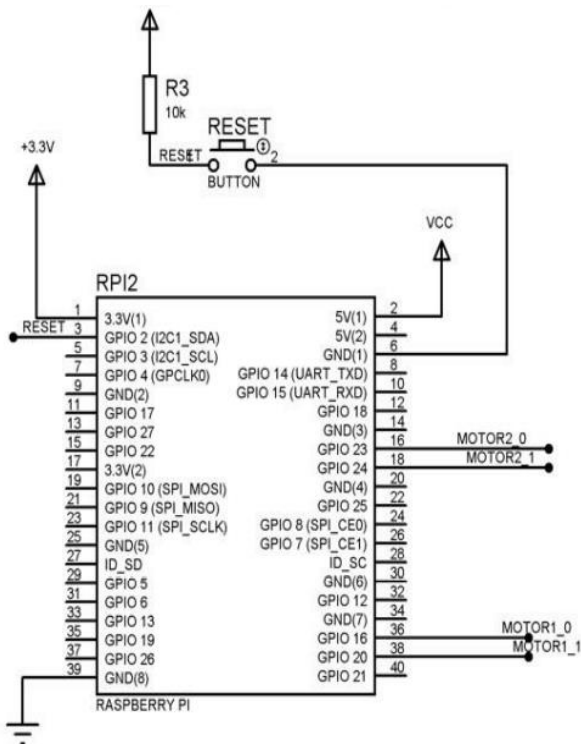

Figure3: Interfacing of L293D driver with Raspberry Pi

## V. SOFTWARE REQUIREMENT

Python is a dynamic, high-level, general-purpose, and interpreted programming language. It allows the development of programmes using an object-oriented approach. It offers a large number of high-level data structures and is straightforward and simple to learn. Because it is a powerful yet simple to learn scripting language, it is appealing for application development.

OpenCV is a huge open-source computer vision, machine learning and image processing library. It basically has an essential role in real-time operations, which are vital in modern systems. It may be used to examine images and videos to locate objects, faces, and even actual handwriting of a person. When combined with other libraries, such as NumPy, Python can easily handle the array of OpenCV structure for analysis.

## VI. METHODOLGY

Input 1 of the L293D gets input from Pin 16 of the raspberry pi and there will be flow of current through output 1. Similarly, Input 2 of the L293D gets input from Pin 20 of the raspberry pi and there will be flow of current through output 2. Pin no 20 and 39 are grounded and enable pins are supplied VCC. A 3.3V is connected to pin 1 of raspberry pi. Motor driver's acquired helps to achieve the desired torque and speed with which motor can run.

Web cam attached to the CSI, captures the image and the image is stored. Image embeds features like distance, color after following an object and tracking it by using the angular motion either on the left, right or in the forward direction. Thresholding is applied to the captured image. Filtering is applied after applying thresholds. Based on the distance of the object from the design, control signals at the port pins of raspberry pi controls the motion of the robot.

## VII. CONCLUSION

The robot designed recognises shape of an object, colour and distance from itself. It also traces its 180-degree motion. The design is less expensive, simpler to install, and easier to troubleshoot when compared to other robots with comparable features on the market. Robotic output responses for moving various objects are precise and acceptable. Object detection and tracking can be used in agriculture, the military, the civil service, security, and for commercial purposes, mostly for surveillance that forms the basis of research work. Another future work can be to create a robot that can detect objects with night vision cameras across a broader area and at a lower cost.

## VIII. REFERENCES

- [1] Risma, P., Dewi, T., Oktarina, Y. and Wijanarko, Y., Neural Network Controller Application on a Visual based Object Tracking and Following Robot. *Computer Engineering and Applications Journal*, 2019, 8(1), pp.31-40.
- [2] R. -J. Wai and Y. -W. Lin, "Adaptive Moving-Target Tracking Control of a Vision-Based Mobile Robot via a Dynamic Petri Recurrent Fuzzy Neural Network," in *IEEE Transactions on Fuzzy Systems*, vol. 21, no. 4, pp. 688-701, Aug. 2013, doi: 10.1109/TFUZZ.2012.2227974.
- [3] Isaac-Medina, B.K., Poyser, M., Organisciak, D., Willcocks, C.G., Breckon, T.P. and Shum, H.P., Unmanned aerial vehicle visual detection and tracking using deep neural networks: A performance benchmark. In *Proceedings of the IEEE/CVF International Conference on Computer Vision*, 2021, pp. 1223-1232.
- [4] Attar, A., Ansari, A., Desai, A., Khan, S. and Sonawale, D., Line Follower and Obstacle Avoidance Bot Using Arduino. *International Journal of Advanced Computational Engineering and Networking*, ISSN: 2320-2106, 2017,5(4).
- [5] Ismail, R., Omar, Z. and Suaibun, S., October. Obstacle-avoiding robot with IR and PIR motion sensors. In *IOP*

Conference Series: Materials Science and Engineering ,2016,Vol. 152, No. 1,

[6]. Leigh, A., Pineau, J., Olmedo, N. and Zhang, H., Person tracking and following with 2d laser scanners. In *2015 IEEE international conference on robotics and automation (ICRA)*, May 2016, (pp. 726-733).

[7]. Amir, S., Siddiqui, A.A., Ahmed, N. and Chowdhry, B.S., Implementation of line tracking algorithm using Raspberry pi in marine environment. In *2014 IEEE International Conference on Industrial Engineering and Engineering Management* ,December 2014,pp. 1337-1341.

[8] D. K. Yadav, S. Mookherji, J. Gomes and S. Patil, "Intelligent Navigation System for the Visually Impaired - A Deep Learning Approach," *2020 Fourth International Conference on Computing Methodologies and Communication (ICCMC)*, Erode, India, 2020, pp. 652-659, doi: 10.1109/ICCMC48092.2020.ICCMC-000121.

[9] International Research Journal of Engineering and Technology (IRJET) e-ISSN: 2395-0056 Volume: 04 Issue: 07,| July -2017.

