



## SIMULATION AND IMPLEMENTATION OF SOLAR PV BASED MULTILEVEL INVERTER FOR BLDC MOTOR DRIVE

<sup>1</sup>PALISETTY MOHAN KRISHNA, <sup>2</sup> AKULA PRASADARAO

<sup>1</sup>PG Scholar, <sup>2</sup> Associate Professor,

<sup>1,2</sup>Department of Electrical and Electronics Engineering,

<sup>1</sup>Viswanadh institute of technology and management, Visakhapatnam, India

**ABSTRACT:** BLDC motor's simple design and great efficiency, as well as its minimal maintenance and cheap cost, these are frequently utilized in high power & low voltage applications. They also have a high-power output and a high torque per unit volume. The BLDC motor operates on an alternating current source, despite the fact that it is a DC motor in this case, the BLDC motor is powered directly from the AC supply port; however, the primary disadvantage is that any interruptions in the source will have an influence on the applications that rely on BLDC motors in the industrial setting. As a result, there should be a converter and an inverter medium between the motor and the source in order to prevent this. There are three different methods to drive the BLDC motor. 1. Two-level inverters build on Pulse Width Modulation (PWM). 2. Inverter with several levels of operation. 3. Multilevel inverter with neutral clamping. By using the multicarrier PWM approach, the suggested inverter may minimize the harmonic content of the output signal. It is capable of generating high-quality motor currents. Using a three-level diode clamped multilevel inverter, the speed of a BLDC may be accurately regulated in this application.

The primary goal of this study is to demonstrate how to operate a BLDC drive with an inverter, where the harmonics may be decreased by utilizing an inverter. The diode clamped multi-level inverter is a device that converts voltage into current. This research provides a more effective alternative to this practice. By simulating the performance of the neutral clamp multilevel inverter-based drive system that use the MATLAB Simulink software package, it is able to assess the overall efficacy of the system. In the event of a power loss, the whole application will cease to function and provide output. Consequently, under these circumstances, in order to increase the dependability of electricity supply and production, it should turn to renewable energies. Different renewable energy sources are available; however, solar PV system instead of conventional power supply because of its benefits have to choose, and a diode clamped multi-level inverter was utilized to drive the BLDC.

**Keywords:** BLDC, Multi-level Inverter, Neutral Point Clamped Diode, THD, Multicarrier PWM, firing circuit.

### I. INTRODUCTION

There are numerous advantages to using a BLDC motor, including high efficiency, low maintenance requirements, reduced weight, and a much more compact design. Because of its inherent advantages, BLDC motors have indeed been extensively employed in a variety of industrial applications for many years. As a result of their great efficiency and the fact that they can be regulated easily across a broad speed range, they are the most ideal motors for applications needing rapid dynamic response in speed response. Motor drive topology built on Multi-Level Inverter (MLI) technology are becoming more prevalent in the motor drive industry. Three-level topologies have the advantage of allowing multilayer voltage waveforms to be created with equipment with reduced voltage rating, which would be a considerable benefit. The objective of multilevel inverters is to generate sine values using discrete voltage levels, whereas the purpose of Pulse Width Modulation (PWM) approaches is to generate sinusoids with changing voltage and frequency, respectively. Multilevel inverters are used to generate sinus voltages from discrete voltage levels. By delivering different gate signals to the MOSFETs, it is possible to produce sinusoids with three phases for a variety of voltages. PWM for inverters has been implemented using a variety of ways that have been developed. Sine-Triangle PWM (SPWM) & Space Vector PWM (SVPWM) are the two most often used approaches for producing PWM for multilevel inverters (SVPWM). Multilevel Sine Triangle PWM would be a type of pulse width modulation in which a PWM signal is generated by making comparisons a reference signal with a large number of level shifted carriers at different levels..

There have been several prior studies conducted on the speed control of various motors employing multilayer inverter systems, all of which have been published. Some of them have been enrolled in this organization. It was hypothesized by Yousif Ismail Al Mashhad and colleagues [1] that the brushless direct current (BLDC) motor has a wide spectrum of uses in high-power systems. It is easy to make, inexpensive, takes less maintenance, has better efficiency, and produces a significant amount of power in the output unit. An inverter drives the BLDC motor, which is a direct current motor. Design and modelling of a 3-phase three-level inverter

for driving a brushless DC motor are presented in this study. It offers a three-phase voltage source that may be controlled in terms of phase, amplitude and frequency. This research uses MATLAB Simulink to simulate the system and illustrate the functioning of the system. A detailed description of the modular 3 -phase multilevel inverter design for brushless dc motor driving is provided by Devi Kiran and colleagues [2]. While both switch in a single leg conduct at the very same time during operation, this signals that the power supply has been short circuited and must be repaired. At this moment, half of the power is dispersed via each switch, resulting in a reduction in the severity of the power cell's explosion by 50%. This improves system reliability while also being cost-effective and reducing system costs.

### II. SYSTEM MODEL

The block diagram of a 3-phase induction powered by a multilevel inverter. All of the system's components will be separated into two sections: the power supply circuit and the control circuit, respectively. An inverter with three output phases and a power rectifier make up the power section. A filter capacitor as well as a 3-phase diode clamps multilevel inverter complete the power section. A servo motor drive connects the motor to the multilevel inverter, allowing it to operate independently of the inverter. alternating current (AC) input voltage is given to a three-phase diode bridge rectifier in order to generate direct current (DC) output voltage via a capacitor filter. dc output voltage A capacitor filter is a device which reduces the amount of ripple content that really is present in the alternate current output voltage when it is used. The pure dc voltage is given to the three-phase multilevel inverter, which subsequently runs as a result of the use of the capacitor filter. An alternating current (AC) output voltage is generated from a direct current (DC) input voltage by use of 12 MOSFET switches, which are operated in parallel (DC). A microcontroller, an opto-coupler, as well as a gate driver circuit are the three components that make up the control circuit of the suggested system, respectively. Specifically, the microcontroller is in charge of creating the gating signals that are required in order to activate the power MOSFET switches that are integrated into the multilevel inverter system. The gate pulses produced by the microcontroller have a voltage magnitude of around 5V when they are generated. Input voltage for the BLDC motor drive is provided by the regulated ac electrical output voltage.

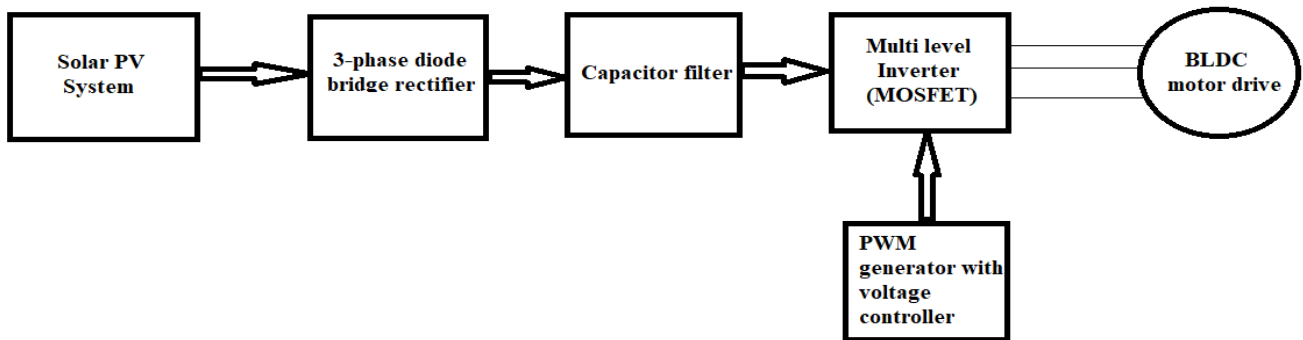

Fig.1. Block diagram of BLDC Motor

### III. MODELLING OF SYSTEM MODEL

#### A. Multi-Level Inverter Type BLDC Drive

Fig.2. shows the Simulink model for multi-level inverter type BLDC drive. The model for multi-level inverter type BLDC drive consist of source, multi-level inverter which consist 12-mosfet based power electronics control valves in order to get input signal to the BLDC drive which having induction motor driver circuit. In this Vabc, Iabc are the inverter output voltages and currents

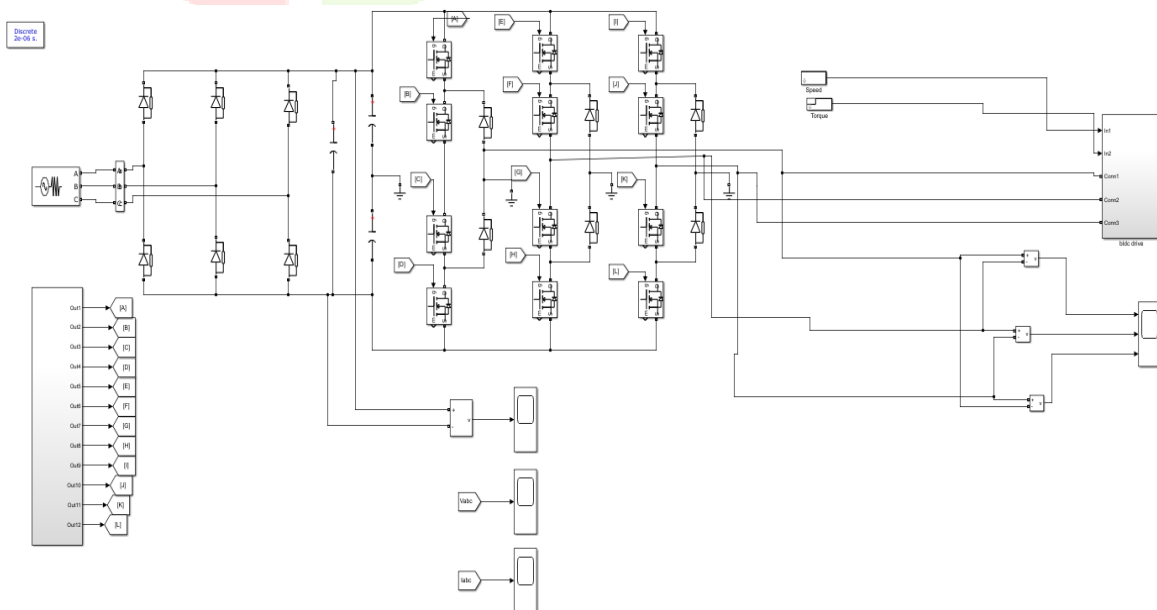

Fig.2. Simulink model for multi-level inverter type BLDC drive

**B. BLDC drive circuit**

The AC7 block of the Specialized Power Systems library is changed in this circuit. Sensor-free DC motor drive including brake chopper for one 3HP motor is shown in this model. Speed & hall sensors are no longer required for the AC7. A back-emf observer is used to determine the motor's speed & location from the voltages and currents at the motor's terminals. Every 60 electrical degrees, the rotor position generates commutations signals (equal to hall effect signals).

Using a Universal Bridge Block, a PWM voltage source inverter drives a trapezoidal back-EMF synchronous motor. The torque benchmark for the current control block is generated by a PI regulator in the speed control loop. When the torque reference is computed, a three-phase current regulator is used to supply the motor with the three reference motor line currents in cycle with the back electromotive forces. Motor current, speed (actual and predicted), & torque signals are all accessible at the block's output terminals.

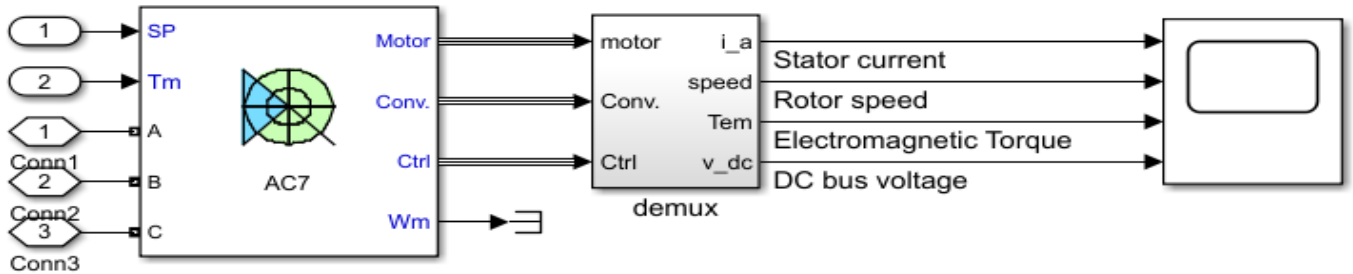

Fig.3. BLDC drive circuit

**C. Multi- level inverter**

Multilevel inverter-fed BLDC motors are presented in this study. A sequential bank of Capacitors powers the diode clamped inverter, which generates numerous voltage levels. Only 50% of dc bus voltage may be seen across the switches. The voltage source inverter's power rating is practically doubled as a result of these qualities. Using multicarrier PWM, the suggested inverter may minimise harmonic content. It produces high-quality motor currents. A three-level diode clamp multilevel inverter is used to accurately regulate the speed of a BLDC.

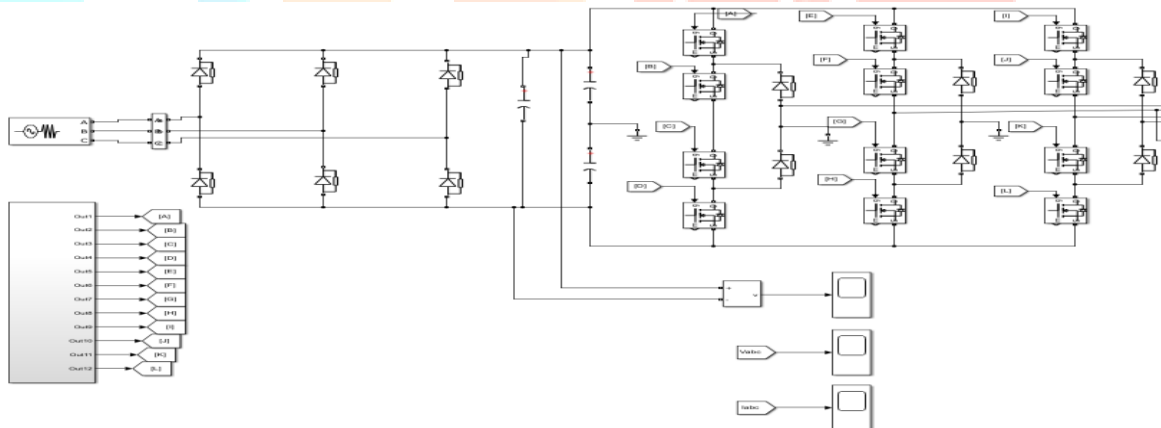

Fig.4. multi-level inverter simulation

Figure 4 depicts the 3-level neutral point-clamped source of voltage inverter. It has a total of 12 active unidirectional switches & 6 neutral point clamp diodes. In this example, "n" could be specified as the neutrality point between the two capacitors. Since each switch only needs to block one-half ( $V_{dc}/2$ ), this set-up has a lot of advantages. In order to create three levels, 2 of the switches within every phase leg should be turned on at the same time at any given point. In order to split the dc bus voltage into three different levels, two bulk capacitors,  $C_a$  and  $C_b$ , are connected in series. They have identical ratings. Diodes of the same kind are used to provide equitable voltage sharing or, while the switch is off, to clamp the very same reference voltage across it. As a result, the voltage stress placed on the switch is lowered significantly.

There are three stages to synthesis three-level voltages from an inverter leg. Activate all top switches  $A_1$  &  $A_2$  to achieve an output voltage level of  $V_{ao}=V_{dc}/2$ . 2. Switch on one upper switch  $A_2$  & one lower switch  $A_1'$  to set the output voltage  $V_{ao}$  to 0 volts. As illustrated in figure 5, with an output voltage level  $V_{ao}=-V_{dc}/2$ , switch on all lower half switches  $A_1'$  and  $A_2'$ . The proposed BLC SC converter works in group inductor current mode and is accustomed to bring the power variable of the AC framework to 1 utilizing a solitary voltage sensor. The speed of the BLDC engine is constrained by differing the DC transport voltage of the voltage source inverter (VSI) that controls the BLDC engine through the PFC converter. Along these lines, the BLDC engine is electronically exchanged so the VSI works with major recurrence exchanging and lessens exchanging misfortune. Also, the unbridged setup of the CSC converter has a lower conduction misfortune on the grounds that the front diode span rectifier is somewhat overlooked.

**Firing circuit:** firing circuit designed for multi-level inverted is based on the pulse width modulation technic where PWM is a modulation technique that generates variable-width pulses to represent the amplitude of an analog input signal. The output switching transistor is on more of the time for a high-amplitude signal and off more of the time for a low-amplitude signal.

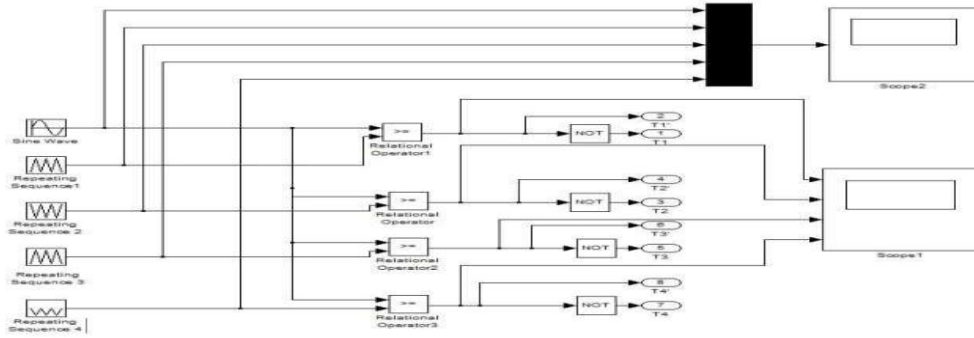

Fig.5. Firing circuit

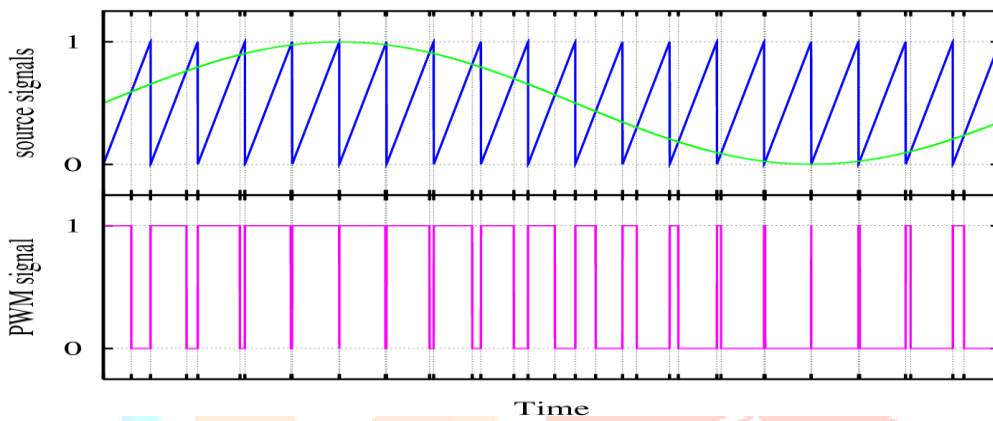

Fig.6. PWM waveform

#### IV. SIMULATION RESULTS

##### A. BLDC drive results:

As the input supply source magnitude having 250-line voltage with 50 Hz frequency, the output from the multilevel inverter that is input stator current to BLDC motor is having 10A. and with that magnitude the stator speed will be 1500 rpm and the torque that the motor have is 20 N-M and the output DC-bus voltage is 330v as shown in fig 7. ( BLDC drive characteristics)

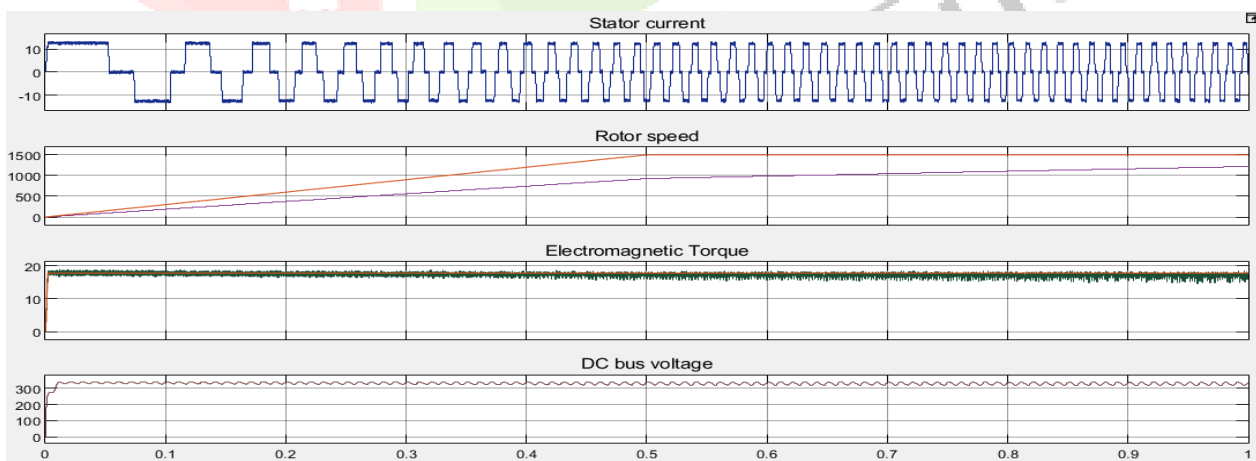

Fig.7.BLDC drive characteristics

**B. Inverter results**

These are the inverter output voltages shown in fig 8. of line to line voltages  $V_{ab}$ ,  $V_{bc}$ ,  $V_{ca}$ . Fig.9. depicts the voltage of the output DC bus, whereas Fig.9. depicts the voltage of the output converter

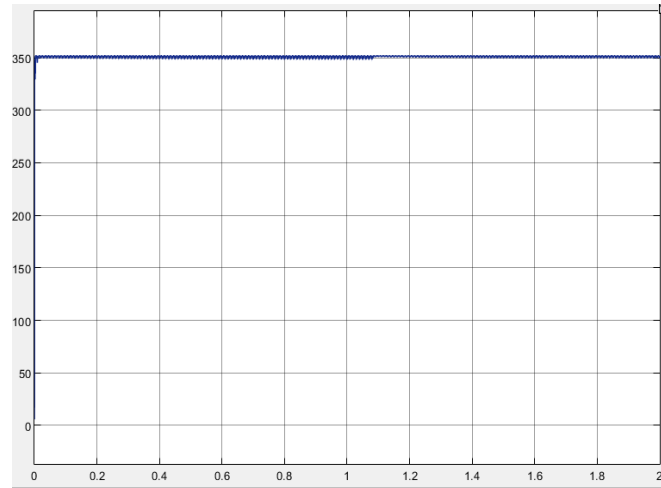

Fig.8. Inverter output voltages of line-to-line voltages  $V_{ab}$ ,  $V_{bc}$ ,  $V_{ca}$ .

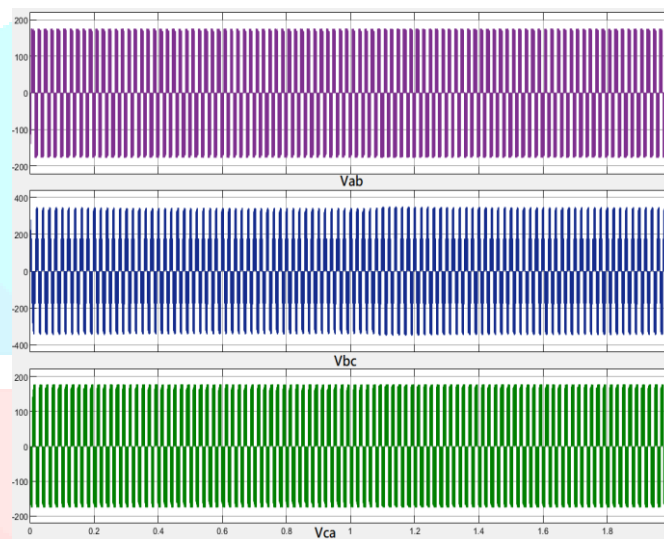

Fig.9. DC bus voltage

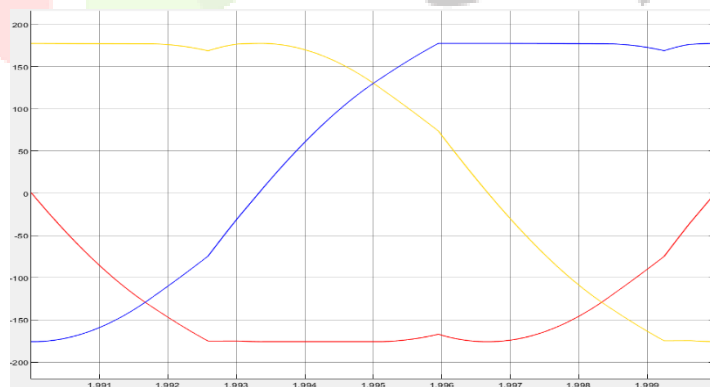

Fig.10. converter output voltage

**C. Results with solar PV system based multi-level inverter**

Solar PV system model shown in fig.11, having two inputs one is solar irradiance (1000) and second one is solar temperature (25degree centigrade) as constant values which are given to solar panel having 10 parallel strings and each string having series connected modules of 1000 which will give approximately 800v output voltage and 80 amperes of current that is given to BLDC motor drive.

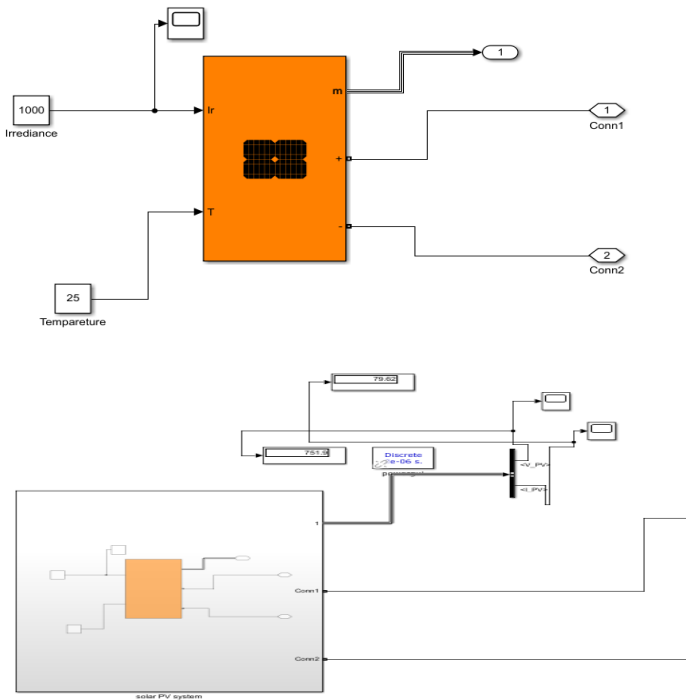

Fig.11. Solar PV system

BLDC drive characteristics with solar PV system as input source having same characteristics without any deviation so from this we can conclude that the solar PV system can be used as conventional energy source instead of available AC source as shown in fig. 12 and fig 13.

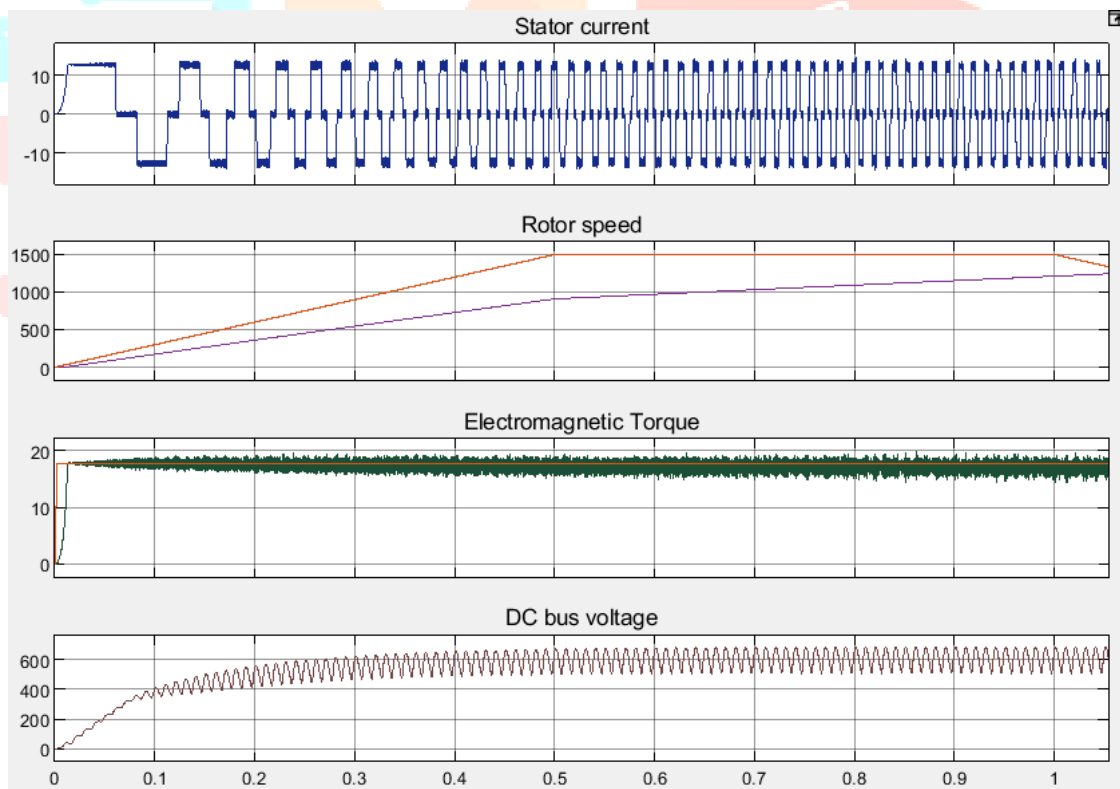

Fig.12. Inverter output voltage with Solar PV system as energy source



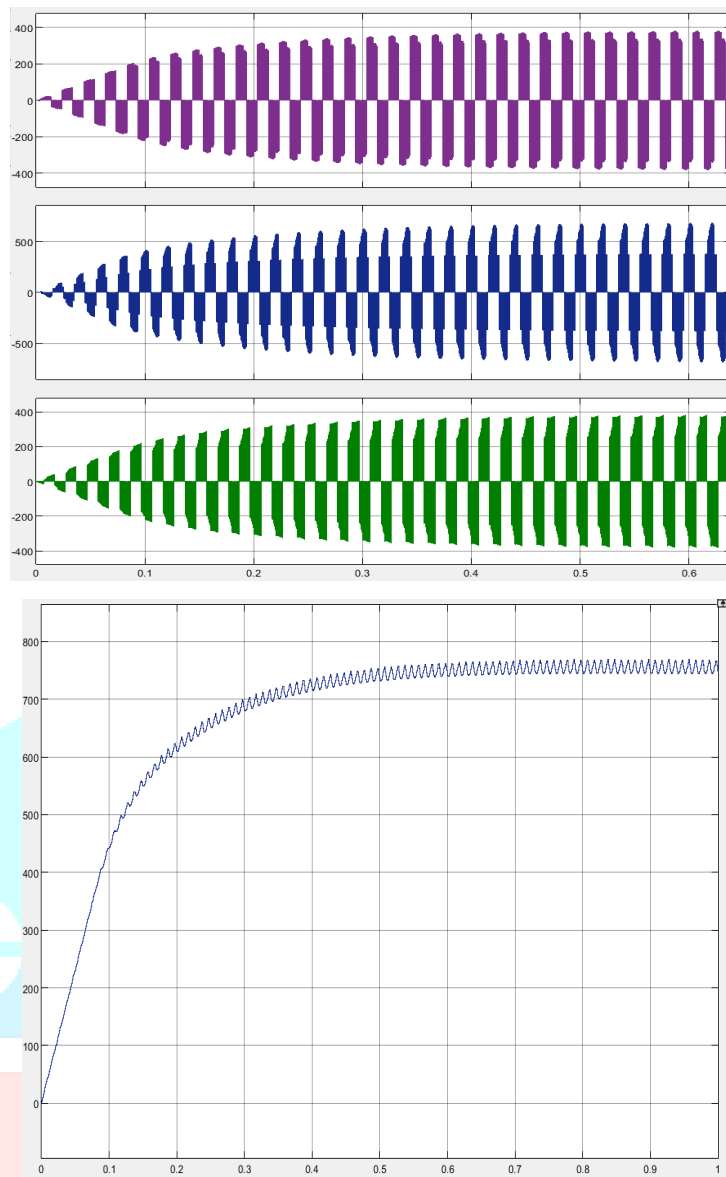

Fig.13. DC Voltage output with solar PV system.

## V. CONCLUSION

It is shown in this paper that a diode clamp with a multilevel inverter for BLDC motor controlling applications may be implemented. The multicarrier PWM technique might be employed to offer the lowest harmonic distortion in the outputs, leading to a high output power with little harmonic distortion. Simulink was used to design and simulate a 3-level BLDC motor drive. When compared to a conventional inverter, the overall harmonic distortion is quite low. The BLDC motor was found to achieve speeds ranging from 600 to 900 rpm at different times throughout the experiment. It is possible to use an inverter system in organisations that need variable speed drives, & it could save a significant amount of energy due to the decreased harmonic losses that it possesses. The number of levels may also be raised in order to further reduce the amount of harmonic distortion produced. BLDC drive characteristics with solar PV system as input source having same characteristics without any deviation so from this, we can conclude that the solar PV system can be used as conventional energy source instead of available AC source. MATLAB was used to create the simulation implementations circuit. Between 600 - 900 rpm were determined to be the most common speeds. There was also a simulation of the PWM waveform as well as outputs of the three-level multilevel inverters system.

To carry out the plan of the BLDC engine regulator utilizing the PWM-based inverter with the variation of the power factor revision methods which will enhance handling, location and recognition activities to further develop the shut circle execution of the total system. Moreover, the wave of the speed bend of the brushless DC engine can be decreased by accurately synchronizing the Hall Effect sensors and the pulses created by the spatial vector - adjustment of the pulse width.

**REFERENCES**

- [1] Yousif Ismail Al Mashhadany , “High-performance multilevel inverter drive of brushless DC motor”, International Journal of Sustainable and Green Energy, Vol. 4, pp 1-7, October 2014
- [2] P. Devi Kiran, M. Ramachandra Rao, “Two Level and Five Level Fed BLDC Motor Drive”, International Journal of Electrical and Electronics,  
Vol. 3, Issue 3, pp 71-82, August 2013
- [3] A. Purna Chandra Rao, Y.P. Obulesh, Ch. Sai Babu, ”High Performance Cascaded Multilevel Inverter fed BLDC Motor Drive”, International Journal of Engineering Sciences and Emerging Technologies, Vol. 5, Issue 2, pp: 88-96, June 2013
- [4] S.Flora Viji Rose<sup>1</sup>, Mr.B.V.Manikandan , “Simulation and Implementation of Multilevel Inverter Based Induction Motor Drive”, International conference on control automation and energy conservation, Chennai 4-6 June 2009
- [5] Jose, Steffen Sernet, Bin Wu, Jorge and Samir Kouro, “ Multilevel Voltage Source - Converter Topologies for Industrial Medium - Voltage Drives” , IEEE Trans on Industrial Electronics, Vol.54, Issue 6, December 2007t
- [6] P.Thirumuraugan, R.Preethi, “ Closed Loop Control of Multilevel Inverter Using SVPWM”, International Journal of Advanced Research in Electrical, Electronics and Instrumentation Engineering, Vol. 2, Issue 4, pp 1561-1572, April 2013
- [7] A. Yadav, J. Kumar, “Harmonic Reduction in Cascaded Multilevel Inverter”, International Journal of Recent Technology and Engineering, Vol.2, Iss. 2, pp 147-149, May 2013
- [8] C. G. Real, E. V. Sánchez, J. G. Gil, “Position and Speed Control of Brushless DC Motors Using Sensorless Techniques and Application Trends”, Sensors, pp 6901- 6964, 2010
- [9] M. Rajshekar, V. G. Swamy, T.A. Kumar, “Modeling and simulation of discontinues current mode inverter fed permanent magnet synchronous motor derive”, Journal of Theoretical and Applied Information Technology, , pp. 64-94, 2011

