



# INTERNATIONAL JOURNAL OF CREATIVE RESEARCH THOUGHTS (IJCRT)

An International Open Access, Peer-reviewed, Refereed Journal

## Different Types of MPPT Techniques

Sandesh R Kempawade<sup>1</sup>, Mukund S Mahagaonkar<sup>2</sup>,

<sup>1</sup>Student, Walchnad College of Engineering Sangli

<sup>2</sup>Assistant Professor, Walchand College of Engineering Sangli

**Abstract**— We are aware that the sole free source for the PV module in our environment is the sun. The PV cell transforms solar energy into electrical energy when the sun shines on it. Today, solar energy plays a major part in meeting our needs for energy. However, occasionally this solar energy is insufficient to meet this need. In those instances, we apply MPPT techniques, which boost power generation and have the major benefit of working in any environment. **MAXIMUM POWER POINT TRACKER** is the full name of the MPPT software. It does not rely on any environmental factors and derives the maximum power from the available PV unit. *In this paper, we go into great detail on several skills and how they might maximise system convergence, efficiency, and implementation costs. We demonstrate that all types of MPPT strategies in this study.*

**Index Terms**— Photovoltaic System PV, MPPT, DC-DC Converter, Micro-Grid, and Mppt Techniques.

### I. INTRODUCTION

Natural resources including sunlight, wind, rain, tides, and geothermal heat all contribute to renewable energy. These resources can be replenished naturally and are renewable. For all intents and purposes, these resources are therefore unbounded, in contrast to conventional fossil fuels, which are running out. The global energy crisis has given clean and renewable energy sources additional push to expand and flourish. The adoption of Clean Development Mechanisms (CDMs) is occurring across organisations all around the world. Another significant element working against fossil fuels, in addition to the world's rapidly diminishing fossil fuel sources, is the pollution brought on by their combustion. In contrast, renewable energy sources are believed to be far cleaner than their traditional equivalents and produce energy devoid of the negative impacts of pollution.

### Different sources of Renewable Energy

#### Wind power:

The energy contained in airflows can be captured by wind turbines. Modern turbines have rated outputs that range from around 600 kW to 5 MW. Since the power production is a function of the cube of the wind speed, it increases swiftly as the available wind velocity rises.

Aerofoil wind turbines are a result of recent developments and feature improved aerodynamic structures, making them more efficient.

#### Solar power

The British astronomer John Herschel [5], who is credited with using a solar thermal collector box to prepare food while on a voyage to Africa, is credited with discovering how to harness solar energy. There are two main ways that solar energy can be used. First, the heat that is captured can be converted into solar thermal energy for use in space heating. Incident solar radiation can also be converted into electrical energy, which is the most useful form of energy. This can be accomplished using solar photovoltaic cells [6] or concentrated solar power facilities.

#### Small Hydro power plant

Small hydropower is defined as hydropower installations under 10 MW and is included in the category of renewable energy sources [7]. These entail using water turbines to transform the potential energy of water contained in dams into useful electrical energy. Run-of-the-river hydroelectricity tries to make use of water's kinetic energy without the need to construct dams or reservoirs.

#### BIOMASS

Biomass plants use the process of photosynthesis to absorb solar energy. When burned, these plants unleash the entrapped energy. Biomass serves as a kind of natural battery that can store solar energy [8] and release it as needed.

#### GEOTHERMAL

The thermal energy that is produced and stored [9] within the layers of the Earth is known as geothermal energy. As a result of the gradient that has formed, heat is continuously transferred from the earth's core to its surface. It is possible to exploit this gradient to superheat water, which can then be used to power steam turbines that produce energy. Geothermal energy's main drawback is that it is typically only useful in places close to tectonic plate boundaries, despite the fact that this technology has recently advanced [10].

**II. MPPT(maximum power point tracker)**

It is sometimes referred to as "simply power point tracking" and is essentially used in PV solar and wind systems to maximise electricity in various environments. Yes, the solar power system is mostly used to enhance power owing to the abrupt climate change in the majority of the area. In essence, MPPT is an algorithmic type that incorporates a controller to optimise the power from a PV system. The maximum power point or peak power voltage is the greatest voltage that a PV solar system is capable of producing. With the use of MPPT, the PV solar cell temperature can be increased to 18V on extremely cold days when it drops to approximately 15V on hot or bright days. The best PV module and associated battery with the best power output are identified by the MPPT, which converts them to provide the maximum current to the battery. This is how MPPT operates: it is connected to the PV system. Additionally, it is beneficial to power the DC load that is directly linked to the battery.

**Description of PV Generator: -**

The solar cell's corresponding circuit is depicted in fig. This figure includes a parallel resistance, a current source that produces light, and a series resistance.

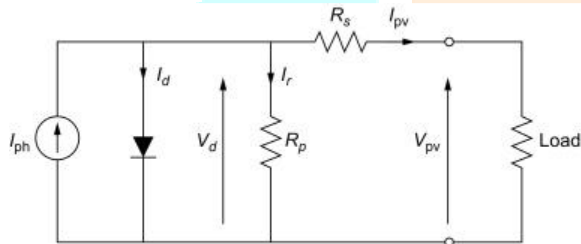

Fig 1. Equivalent circuit of photovoltaic cell

$$I = I_{ph} - I_{sat} \cdot \left[ \exp\left(q \cdot \frac{V + R_s \cdot I}{nkt}\right) - 1 \right] - (V + R_s \cdot I) / R_{sh}$$

Here I= denotes the solar array current,  
 V= denotes the output voltage, I<sub>ph</sub> =denotes the light generated current  
 I<sub>sat</sub>= shows the reverse saturation current  
 Q= electronic charge which is 1.6\*10<sup>-19</sup> C N is the deviation factor;  
 K is the Boltzmann constant which is standard value is 1.3807.  
 R<sub>s</sub> denotes the series resistance which is connected to the series with the load.

**III. Different MPPT techniques**

There are different techniques used to track the maximum power point. Few of the most popular techniques are:

- 1) Perturb and Observe (hill climbing method)
- 2) Incremental Conductance method
- 3) Fractional short circuit current
- 4) Fractional open circuit voltage
- 5) Neural networks
- 6) Fuzzy logic

**1) Perturb and Observe**

The simplest way is Perturb & Observe (P&O). This has a low implementation cost and is therefore simple to implement because we only need one sensor, a voltage sensor, to sense the voltage of the PV array. The temporal complexity of this algorithm is really

low, but when it approaches the MPP, it keeps perturbing in both directions. This indicates that the algorithm is extremely close to reaching the MPP, and at this point we have the option of either specifying an appropriate error limit or using a wait function, which increases the method's time complexity.

The method, however, disregards the rapid change in irradiation level (which changes MPPT) and interprets it as a change in MPP as a result of perturbation, which leads to the computation of the inaccurate MPP. To circumvent this problem, we can use the incremental conductance method.

**2) Incremental Conductance**

Two voltage and current sensors are used in the incremental conductance method to measure the PV array's output voltage and current.

At MPP the slope of the PV curve is 0.

$$(dP/dV)_{MPP} = d(VI)/dV \dots\dots\dots (1)$$

$$0 = I + VdI/dVMPP \dots\dots\dots (2)$$

$$dI/dVMPP = - I/V \dots\dots\dots (3)$$

The solar panel's immediate conductance is shown on the left side. MPP is obtained when this instantaneous conductance reaches parity with solar conductance. Here, we are concurrently monitoring the voltage and the current. Consequently, the mistake caused by a change in irradiance is removed. However, implementation becomes more difficult and expensive. The complexity and implementation costs of the algorithms keep rising as we move down the list, which may be appropriate for a highly complex system. Because of this, the Perturb and Observe and Incremental Conductance algorithms are the most popular ones. The Perturb & Observe approach was the one we decided to use for our study among the two due to its ease of implementation.

**3) Fractional open circuit voltage**

The fractional VOC approach was made possible by the almost linear relationship between VMPP and VOC of the PV array under various levels of irradiance and temperature.

$$VMPP = k1 Voc \dots\dots\dots (4)$$

where k1 is a

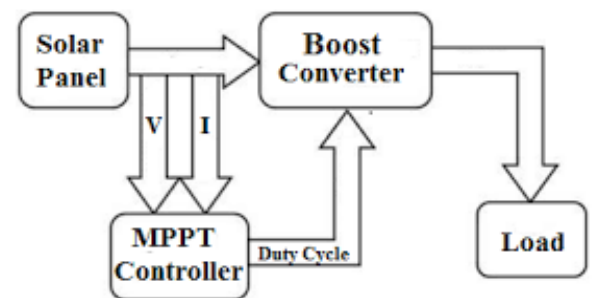

proportionality constant. Because k1 depends on the properties of the PV array being utilised, it is typically necessary to determine it beforehand by empirically determining VMPP and VOC for the particular PV array at various irradiance and temperature levels. According to reports, the value of k1 ranges from 0.71 to 0.78. Once k1 is known, VMPP can be calculated using VOC measurements taken periodically while the power converter is briefly turned off. There are drawbacks to this, though, such a brief loss of potency.

**4) Fractional short circuit current**

Because IMPP is roughly linearly connected to the ISC of the PV array under a variety of atmospheric circumstances, fractional ISC results.

MPPT = k2 Isc ..... (5)

where the proportionality constant k2 is used. The PV array being used must be taken into account while determining k2, just like with the fractional VOC method. In most cases, the constant k2 is determined to lie between 0.78 and 0.92. ISC measurement while operation is challenging. In order to periodically short the PV array so that ISC may be measured using a current sensor, an extra switch must typically be added to the power converter.

**5) FUZZY Logic Control**

Over the past ten years, fuzzy logic control for MPPT has gained popularity thanks to microcontrollers. The benefits of fuzzy logic controllers include tolerating nonlinearity, working with erroneous inputs, and not requiring a perfect mathematical model.

**6) Neural Network**

Neural networks are another MPPT implementation method that works well with microcontrollers. Input, hidden, and output layers are the most frequent layers found in neural networks.

Each layer's node count varies and depends on the user. The input variables can be any combination of climatic data such as temperature and irradiance, PV array parameters such as VOC and ISC, or both. Typically, the output consists of one or more reference signals, such as a signal used to drive the power converter to run at or near the MPP.

**Boost type DC-DC Converter**

The MOSFET, boost inductor, filter capacity, output diode, and load resistor are the main components of this sort of converter. The boost inductor increases and the diode enters the off state when the switch K is in the on position, as shown in the fig. When the K is in the off state, all of the power that is being collected is stored in the current inductor and discharged through the diode. By adding a capacitive filter to the circuit and providing dc voltage to the load, the pulsing current caused by the switching action, such as the On and Off mode, is smoothed down. The current transfer function was created by taking into account both dc voltage transfer and steady state operation.

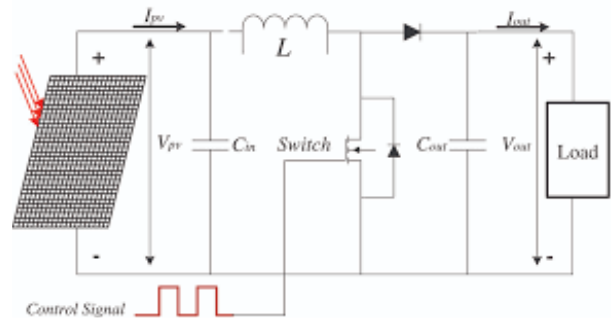

Fig 2. Block diagram of MPPT boost converter

Fig 3 equivalent circuit of MPPT boost converter

**Microgrid of PV System:**

A microgrid, according to the definition, is a collection of interconnected loads and distributed energy that is connected to any centralised grid and can be disconnected from the grid. The grid-connected microgrid offers additional financial advantages and boosts both electricity consumption and production. Microgrid integration with renewable energy sources is also beneficial. adding PV to the microgrid, which greatly aids in supplying the clean and reasonably priced electricity Microgrids are useful to supply the localised supply when the grid is down when the solar system generates the source. Consider the microgrid as the generating unit of the future as we build the PV project. The energy storage system, generators, and other renewable energy sources are all part of the micro-grid.

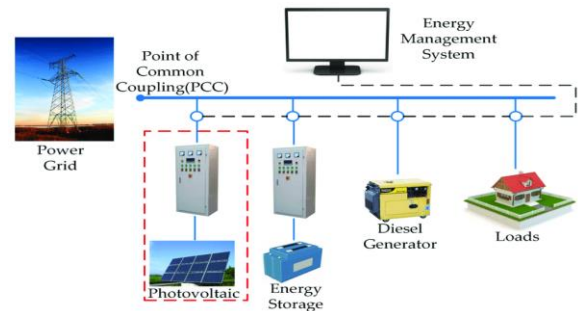

Fig 4 Microgrid PV System

**Perturb & Observe Algorithm**

According to the Perturb & Observe algorithm, when the PV panel's operational voltage is changed by a little amount, if the resulting change in power P is positive, we are moving in the direction of MPP and we continue perturbing in that direction. If P is negative, we are moving in the opposite direction of the MPP and must modify the given perturbation's sign.

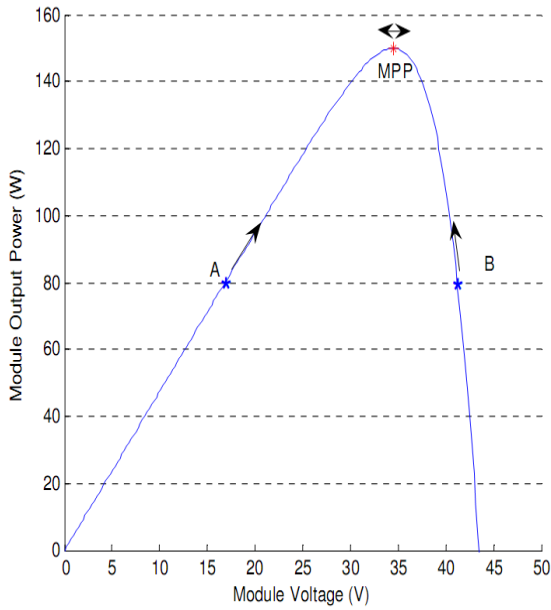

Fig 5 .Solar panel characteristics showing MPP and operating points A and B

The plot of module output power vs module voltage for a solar panel at a specific irradiance is shown in Figure 5. The Maximum Power Point, or MPP, represents the PV panel's theoretically possible maximum output. Take A and B into account as two working points. The point A is located on the left side of the MPP, as depicted in the above picture. As a result, by giving the voltage a positive perturbation, we can move closer to the MPP. Point B, on the other hand, is located on the MPP's right side. To achieve MPP, the direction of the perturbation must be changed since when we apply a positive perturbation, the value of P turns negative. The process flow for the P&O shown in fig 6.

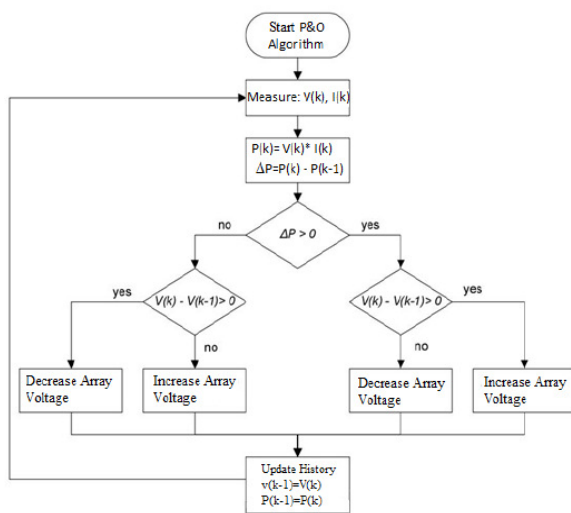

Fig 6 Flowchart of Perturb & Observe algorithm

**Limitation of P&O Algorithm**

The MPP also goes to the right side of the curve when the irradiance is quickly changing. The algorithm interprets this as a change brought on by a perturbation, and in the following iteration, it modifies the perturbation's direction and departs from the MPP, as depicted in the figure.

However, in this technique, we only utilise one sensor—the voltage sensor—to measure the voltage of the PV array, which

lowers the implementation costs and makes it simpler to use. This algorithm has a very low time complexity, but when it gets very close to the MPP, it doesn't stop there and continues to perturb in both directions.

When this occurs, the algorithm has very nearly reached the MPP, and we can either specify a proper error limit or utilise a wait function, which increases the algorithm's time complexity.

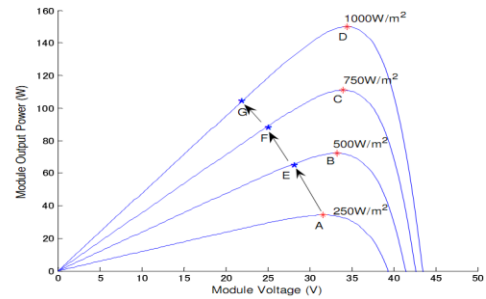

Fig 7 Curve showing wrong tracking of MPP by P&O algorithm under rapidly varying irradiance

**REFERENCES**

1. Gergaud O, Multon B, Ben Ahmed H. Analysis and experimental validation of various photovoltaic system models. 7th International ELECTRIMACS Congress, Montréal, Canada, 2002, pp. 1-6.
2. ESRAM T, Chapman P.L. Comparison of photovoltaic array maximum power point tracking techniques. *IEEE Trans. Energy Conversion*, 2007; 22: 439-449.
3. Tafticht T, Agbossou K, Doumbia ML, Chériti A. An improved maximum power point tracking method for photovoltaic systems. *Renewable Energy*, 2008; 33: 1508-1516.
4. Published By: Lattice Science Publication © Copyright: All rights reserved. Retrieval Number:100.1/ijee.A1809051121 DOI:10.35940/ijee.A1809.111221
5. Enrique JM, Duràn E, Sidrach-de-Cardona M, Andújar JM. Theoretical assessment of the maximum power point tracking efficiency of photovoltaic facilities with different converter topologies. *Solar Energy*, 2007; 81: 31-38.
6. Femia N, Petrone G, Spagnolo G, Vitelli M. Optimization of Perturb and Observe Maximum Power Point Tracking Method. *IEEE Trans. Power Electron.*, 2005; 20: 963-973.
7. Youngseok J, Junghun S, Gwonjong Y, Jaeho C. Improved Perturbation and Observation Method (IP&O) of MPPT control for photovoltaic power systems. *The 31st Photovoltaic Specialists Conference*, Lake Buena Vista, Florida, USA, 2005, pp. 1788-1791.
8. Hussein KH, Mota I. Maximum photovoltaic power tracking: An algorithm for rapidly changing atmospheric conditions. in *IEE Proc. Generation Transmiss. Distrib.*, 1995, pp. 59-64.
9. Kobayashi K, Takano I, Sawada Y. A study on a two stage maximum power point tracking control of a photovoltaic system under partially shaded insolation conditions. in *IEEE Power Eng. Soc. Gen. Meet.*, 2003, pp. 2612-2617.
10. Salas V, Olias E, Lazaro A, Barrado A. New algorithm using only one variable measurement applied to maximum power point tracker. *Solar Energy Material and Solar Cells* 87, 2005, pp. 675-684.
11. Resource and Energy Economics - C Withagen - 1994 - Elsevier
12. Semana Scientifica - L Pedroni - 2004 - Google Books
13. Wind power in Power Systems (Book) - T Ackermann - 2005 - Wiley
14. Analysis of Wind Energy in the EU-25 - European Wind Energy Association - 2007
15. Solar Power (Book) - T Harko