



INTERNATIONAL JOURNAL OF CREATIVE RESEARCH THOUGHTS (IJCRT)

An International Open Access, Peer-reviewed, Refereed Journal

ARDUINO BASED CAR REVERSE PARKING SYSTEM

MALA TC¹, PRAKRUTHI M², YASHWANTH S B³, VASANTH KUMAR C³,
PROF. GAGANAMBHA⁵

¹Student(4VM19EE019), ELECTRICAL AND ELECTRONICS ENGINEERING, VVIET, MYSORE, INDIA

²Student(4VM19EE028), ELECTRICAL AND ELECTRONICS ENGINEERING, VVIET, MYSORE, INDIA

³Student(4VM19EE058), ELECTRICAL AND ELECTRONICS ENGINEERING, VVIET, MYSORE, INDIA

⁴Student(4VM20EE435), ELECTRICAL AND ELECTRONICS ENGINEERING, VVIET, MYSORE, INDIA

⁵Faculty, ELECTRICAL AND ELECTRONICS ENGINEERING, VVIET, MYSORE, INDIA

MODULE

Abstract - There is a rapid development in technology which influencing the human life in several aspects due to rapid development in different fields but still need to adopt that technology such that can make human life more easier to live. In automobiles sector many countries are doing great and launching new products (vehicles). Instead of having many advantages and features have some disadvantages too and one of them in vehicles is reverse car parking. To rectify this problem we have developed a system which will help to park our vehicles in reverse direction without collision with any obstacle in its vicinity. The aim of the project is to present such a design which can identify the obstacles comes in the range while parking the car in reverse direction.

Key Words: Reverse parking, ultrasonic sensor, arduino Uno, Microcontroller, parking sensor.

1.INTRODUCTION

A reverse car parking defect is a term used to describe several scenarios in which cars with automatic transmission can fail to properly engage the parking mechanism, causing the vehicle to unintentionally roll, sometimes resulting in injury or vehicular accidents. The term has significance in product liability law, and in a number of major cases in the United States have been brought in which car manufacturers were accused of negligence for not addressing an alleged dangerous flaw in the transmission. A "park-to-reverse" situation involves a driver who believes that they have shifted into "park" and believing so, and the vehicle not moving when they pull their foot off the brake, proceeds to exit the vehicle. There can then be a delay in vehicle movement sufficient for the driver to either fully or partially exit the vehicle before the vehicle moves. Typically, the vehicle will move backwards. However, when on certain vehicles the shift selector can be placed between the detented park and reverse gear positions; i.e. in "false park" the transmission is in hydraulic neutral, without the parking pawl engaged. As such the vehicle can also roll either forward or back in neutral. While less common, transmissions with the defect, can also be shifted to between "neutral" and "drive", and then self-shift into "drive" or roll (called a "neutral to drive" accident). Park-to-Reverse" issues are nearly always caused by several possible design flaws in a vehicle's transmission which makes it possible for a driver to unknowingly place the vehicle's shift selector into a position in between the "park" and "reverse" gear positions. Yet rather than being in "park", this area is a transitional zone between gears, which is sometimes called "false park". Parking sensors use a type of sonar. The term sonar is an acronym for sound navigation and radar; it's used for calculating the distance and/or direction of an object from the time it takes for a sound wave to travel to the target and back. An ultrasonic sensor is a speaker or microphone that emits or receives ultrasound. There is also a type that can handle both emission and reception. Vehicle parking sensors are equipped with this type of sensor.

2 LITERATURE SURVEY

1. Maher Hassan Kashmir, IJET: In this paper they introduce. a smart parking system based on Arduino components, website and mobile application. The system helps drivers to find an empty park space depending on the number of unoccupied lots in the park. This can increase the economy by reducing fuel consumption and pollution in urban cities. Moreover, it helps to reduce the time of finding car lot. Also, it helps the driver to find his car when he forgets the car location easily. Finally, the system shows the reserved, booked and empty lots in park for staff and drivers.”

2. “M. Kannan , Mrs. L. William Mary , Dr. C. Priya , Dr. R. Manikandan ,IEEE: In this paper they proposes a new architecture with an algorithm for better to park the vehicle further in this document, examine the parking availability status of the registered and / or reserved vehicle to park the vehicle and examine the sensor-based intelligent parking system. The main intention of the car parking system is to distribute the slot in the parking area without becoming rigid for vehicle parking.”

3. “Mohammed Omar Ba Sabbea, MuhammedIrfan, A. H. M. Almawgani, HishamAlghamdi, In this paper they explain the developed system that has capability to control the entry of authorized vehicles in parking area and block unauthorized vehicles.”

2.1 OUTCOME OF LITERATURE SURVEY

From the literature survey we came to know the importance of car parking. The above literature surveys are about smart parking and automatic car parking . For this proper reverse parking is needed which is complicated for drivers in congested areas. This problem can be solved by designing a proper reverse parking sensor with alarm system and LCD for knowing the actual distance between car and obstacle.

3 PROBLEM STATEMENT

From the research, there are a few factors why the accidents occurred because reverse parking problem happened: Driver fail to detect obstacles behind the car. The common alarm system is not efficient. Driver unable to determine the distance between the car and obstacles.

4 OBJECTIVE

1. Almost all modern cars are equipped with reverse parking sensors that are activated when the car is put in reverse gear and beep at variable rate depending on the distance between the car and the closest obstacle.

2. The Reverse Parking Sensors that are equipped in the car are basically Ultrasonic Proximity Sensors i.e. they use Ultrasonic Sensors to measure the distance between the car and the object and warn the driver if the car is too close. In this project, we have built a simple prototype of a Car Reverse Parking Sensor with the help Arduino UNO and the very famous HC-SR04 Ultrasonic Sensor.

5 METHODOLOGY

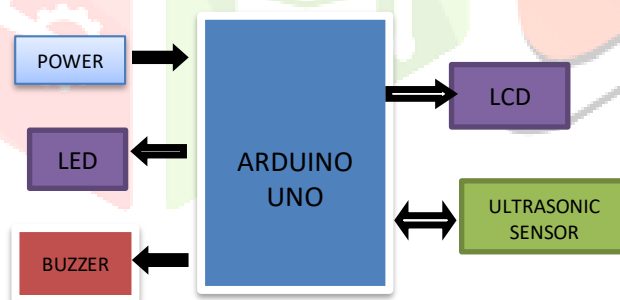

Figure 5a- Block diagram

The figure 5a represents the working of the Reverse parking system. The Ultrasonic sensor is used to measure the distance and Arduino Uno acts as control unit which controls sensor calculates the distance and activates the buzzer. Initially, ultrasonic sensor transmits acoustic pulses and receives the reflected pulses, Arduino makes use of the time interval of the reflected pulses and calculates the distance between the object and sensors, microcontroller will activate the buzzer and if the distance is less than 20 cms the buzzer and LEDs activates. The measured distance is continuously displaced on the LCD. We can modify the code to increase the intensity of buzzer with decrease in the distance. The ultrasonic sensor consists of 4 pins: VCC, TRIG, ECHO and GND. VCC, GND are in connection with +5V and GND of the power supply while the TRIG and ECHO are connected to Digital I/O pins of Arduino respectively. Buzzer of 5V is used and LED is connected along with a 1KΩ resistor.

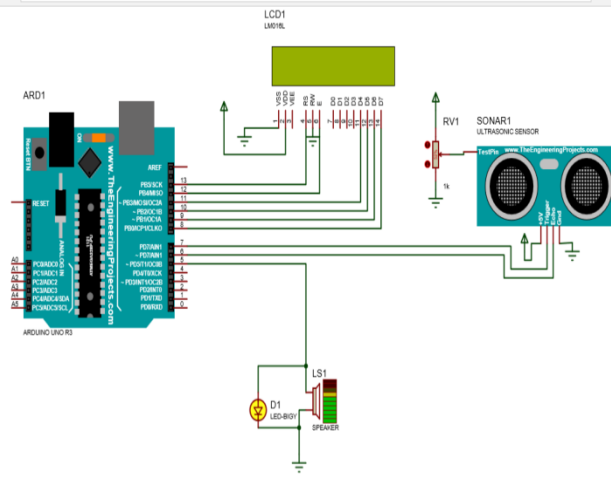

Figure 5b- pin diagram

5.1 HARDWARE REQUIREMENT:

The following project consists of the following parts:

- 1. Arduino Uno
- 2. Ultrasonic sensor
- 3. LCD
- 4. buzzer
- 5.LED's

5.2 SOFTWARE REQUIREMENT:

The following project consists of the software's:

- 1 Arduino ide
- 2. Proteus design suite

6 HARDWARE IMPLEMENTATION



Figure 6 -hardware implementation

7 RESULTS AND DISCUSSIONS

The aim of this project prototype is it to design an reverse parking system which will assist the driver to make parking easily. we can detect an obstacle behind the car within a range of 2cm to 400cm. The Arduino will start measuring the distance of the objects in front of the Ultrasonic Sensor. If the computed distance is less than 20 cm(for this prototype) then Arduino activates the buzzer.

The distance of the obstacle is continuously displayed on the LCD. If the distance is less than 20 cm, the buzzer and red LED activates and alert signal is signal is displayed on the LCD until the distance between car and obstacle is less than 20 cm.

7.1 Advantages:

- Initial cost is low.
- It is more economical
- Increases safety while reverse parking and avoids damaging of car.
- Decreases fuel consumption and time to search space.
- It is more accurate as it indicates the exact distance between the vehicle and obstacles.

7.2 Disadvantages:

- Very sensitive to extreme environmental changes.
- To sense accurately ultrasonic sensors are need to placed on the bumpers of car, which need to be drilled into bumper which ruins the appearance of car.
- Only detects obstacles in behind the car, obstacles present along the sides will go unnoticed.

7.3 Applications:

- Obstacle moving robots
- Distance measurement

8 CONCLUSION:

In this project ultrasonic sensor is used, which will sense any obstacle in its desired range, with the help of arduino controller. Arduino controller is used control the ultrasonic sensor through our preinstalled program, we also use LCD to display the distance for more accuracy in parking our vehicle, buzzers are used for indication of any obstacles which lie under its range.

8.1 FUTURE SCOPE

- Making it available for all types of vehicle.
- Using several sensor to get proper reading around the whole car not in just reverse direction.
- Automatic Car Parking.
- Effective implementation on Intelligent Parking Assist System (IPAS).
- Can be implemented accident alert system using GSM.

REFERENCES

- [1] <http://www.arduino.org/>
- [2] https://www.youtube.com/watch?v=cVu-UX_jlzg
- [3] <https://snapguide.com/guides/make-an-arduino-parking-sensor/>
- [4] <http://economictimes.indiatimes.com/magazines/et-magazine/how-ultrasonic-parkingsensors-work/articleshow/12572171.cms>
- [5] Chandni Patel, Monalisa Swami, Priya Saxena and Sejal Shah,” Car parking system”,International Journal of Engineering Science and Innovative Technology(IJESIT),Volume 4, Issue 2, March 2015