



# INTERNATIONAL JOURNAL OF CREATIVE RESEARCH THOUGHTS (IJCRT)

An International Open Access, Peer-reviewed, Refereed Journal

## Arduino Based Low-Cost portable ventilator for Covid-19 Pandemic.

Abrar Shaikh<sup>1</sup>, Akshaya Kumar<sup>2</sup>, Amit Kumar<sup>3</sup>, Mr. Vishal B Katekar<sup>4</sup>

Department of Electronics and Telecommunication Dr DY Patil School Of Engineering and Technology, Savitribai Phule Pune University, India

### Abstract

*This Document provides an idea of working and methodology of building a low-cost ventilator. Based on reviewed literature a simple, easy to use, and easy to build design of a low-cost portable ventilator is proposed. The ventilator prototype uses IOT technology to provide real-time tracking of temperature and Breaths per minute of the patient. This ventilator model is assumed to have better working performance than already available in market at a very competitive pricing.*

**Keywords:** Ventilator, Low-cost, Portable, IOT, BPM.

### I INTRODUCTION

The ventilator design focuses on safe operation and reliable production while addressing the specific needs of COVID-19 patients with ARDS. The ventilator blows Air into a pipe with infused Oxygen directly into the lungs of the patient with the help of a mask fitted tightly over their mouth and helps them breathe.

### II. SIGNIFICANCE AND SCOPE

To deliver high concentrations of oxygen into the lungs and help get rid of carbon dioxide to decrease the amount of energy a patient uses on breathing so their body can concentrate on fighting infection or recovering. for a person who is not breathing because of injury to the nervous system, like the brain or spinal cord, or who has very weak muscles it will prove helpful to provide breaths to a patient who is unconscious because of a severe infection

### II. WORKING PRINCIPLE

Basic Principles of Ventilator Design a mechanical ventilator is an automatic machine designed to provide all or part of the work the body must do to move gas into and out of the lungs. The act of moving air into and out of the lungs is called breathing, or, more formally, ventilation. A ventilator blows air into the airway through a breathing tube. One end of the tube is inserted into patient's windpipe and the other end is attached to the ventilator. The breathing tube serves as an airway by letting air and oxygen from the ventilator flows into the lungs. Positive Pressure Ventilators applies pressure inside the chest to expand it and requires tight fitting mask or an artificial airway.

### III. PROPOSED METHODOLOGY

Mechanical ventilators are machines that act as bellows to move air in and out of your lungs. Your respiratory therapist and doctor set the ventilator to control how often it pushes air into your lungs and how much air you get. You may be fitted with a mask to get air from the ventilator into your lungs. Arduino based ventilator. Arduino is programmed with Arduino software. The LCD display is for information and display readings.

Software part programming is through Arduino Uno software (IDE). Easy to write a code can be uploaded and C language is used for programming Arduino Uno kit. Motor driver and motor Potentiometer are used to control the speed of mechanical arm which will control the rate of contraction and expansion.

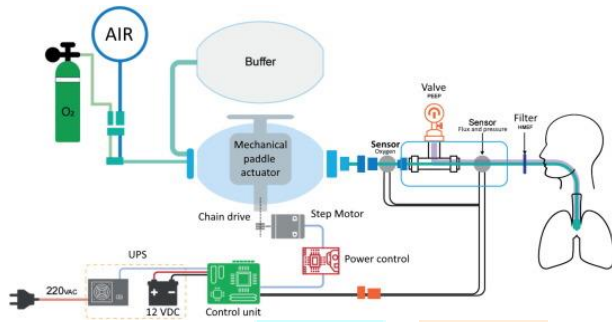

Full breathing circuit

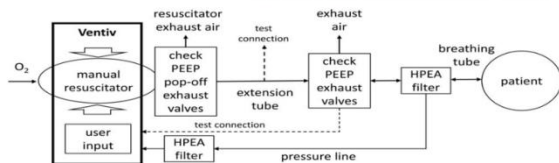

#### IV. CONCLUSION

This project highlights the possibility to build a portable, low-cost ventilator that will have all the basic functions of a ventilator. This ventilator can be used in hospitals and in homes for a short span of time until professional help is provided.

#### REFERENCES

[1] A Research Paper published by Department of Electrical Engineering, Galgotias College of Engineering and Technology Greater Noida, India : April 2021

[2] Report on basic ventilator design by Wojtek Grabczak at [info@fabbaloo.com](mailto:info@fabbaloo.com) : January 2021

[3] Tejpur University, prototype model of ventilator : July 2020

[4] Rice University report on automated bag valve mask unit costing less than 300 USD: April 2020

[5] British home appliances firm GTECH prototype of a medical ventilator by Nick Grey : March 2020

[6] A report on Squeezing a bag valve mask with

motor and Arduino controller by Kathy griffin : March 2020

[7] Massachusetts Institute of Technology open source paper on ventilator : March 2020

[8] Automatic Respiration Control Device by Dr Rajeev Chauhan (PGI Chandigarh, India) : January 2020

[9] Kaczmarek RM. *The mechanical ventilator: past, present, and future.* Respir Care 2011;56:1170–1180.

[10] Roy G Brower, Michael A. Matthay, Alan Morris, David Schoenfeld, B Taylor Thompson, Arthur Wheeler, The Acute Respiratory Distress Syndrome Network. Ventilation with lower tidal volumes as compared with traditional tidal volumes for acute lung injury and the acute respiratory distress syndrome. N Engl J Med 2000;342:1301–1308.

[11] Morch ET. *History of mechanical ventilation.* In: Kirby RR, Banner MJ, Downs JB, editors. *Clinical applications of ventilatory support.* New York: Churchill Livingstone; 1990. pp.1–61.

[12] Mushin WW, Rendell-Baker L, Thompson PW, Mapleson (Online) WW. *Automatic ventilation of the lungs.* Oxford: Blackwell Scientific; 1980.

[13] Woollam CH. *The development of apparatus for intermittent negative pressure respiration.* Anaesthesia 1976;31:537–547

[14] Baker AB. *Artificial respiration, the history of an idea.* Med Hist 1971;15:336–351.

[15] Price JL. *The evolution of breathing machines.* Med Hist 1962;6:67–72.