



Design and Development of 7-switched multilevel inverter 15 Level Using Fuzzy logic Algorithm

K. Dhineshkumar¹, Mamula Jeshwini²

¹Associate Professor, Dept of EEE, Narsimhareddy engineering college, Hyderabad, TS, India

²PG Scholar, Dept of EEE, Narsimhareddy engineering college, Hyderabad, TS, India

ABSTRACT:-

The presence of Harmonics in sun oriented Photo Voltaic (PV) energy change structure brings about crumbling of force quality. To address such issue, this paper expects to explore the end of Harmonics in a sunlight based with fell fifteen level inverter with help of Fuzzy Logic (FL) based regulators. Multilevel inverters have acquired expanded revenue as of late because of their capacity to create top notch output waveforms with a low exchanging recurrence. This makes them alluring for high-power applications. The nature of the output waveform can be expanded by killing the some lower request prevailing Harmonics. Another Multilevel inverter with decreased number of force switches is proposed. This new multilevel inverter dependent on fell H-connect geography. This paper lessens all out consonant contortion (THD). This paper proposes another idea of exchanging recurrence with diminished number of switches. This idea assists with lessening the intricacy of exchanging contrasted with other multilevel inverters. Proposed Multilevel inverter having fifteen level output is approved with a straightforward direct burden. The proposed thought has been approved through simulation.

Index words: Harmonics, multilevel inverter, photo voltaic, Fuzzy Logic Controller

I. INTRODUCTION

This current day's multilevel inverters have gotten basic because of their Voltage activity and capacity ability using many autonomous wellsprings of dc power, the multilevel inverter generates the required output. Using an exchanging recurrence, with a rising number of dc sources, the inverter voltage output waveform is acquired in a nearly sinusoidal waveform [1]. It exhibits low voltage stress and low exchanging difficulties due to a few dc sources. MLI have acquired critical consideration in late past because of their various benefits. The critical idea of MLI is to accomplish the force change in little voltage steps. The little voltage steps advantage to get less exchanging misfortunes and low symphonious contortion, and gadgets having low voltage appraisals and higher productivity. Additionally, it plays out the decrease of Voltage weights on the heap and gives the likelihood of working with low speed power semiconductor gadgets. Such MLI geography improves the proficiency and permits a critical decrease in the size of the output channel. The essential idea of the Multilevel inverter is to combination the ideal AC output voltage

from little dc input voltage source. Multilevel inverter are fundamentally arranged in three sorts, Diode clasped converter [2], flying capacitor MLI [3] and course H-connect MLI [4]. In flying capacitor kind of inverter, number of capacitors required wills increments as we go for more significant levels henceforth adjusting the voltage across the capacitor turns into a significant issue. In diode clasped type, as we go for more significant levels the quantity of cinching diodes required is more which makes the structure complex. Henceforth, to conquer the previously mentioned disadvantages fell H-connect Multilevel inverters can be utilized [5] [6]. These sorts of converter are broadly utilize account of their flexibility and straightforwardness. The fell H-connect multilevel inverters are arranged into two kind's even and uneven converters. In even sort, dc wellsprings of equivalent voltage esteems are utilized for all the H-connect, while in topsy-turvy geography the upsides of voltages sources utilized are not equivalent. In this paper another deviated MLI geography as demonstrated in the underneath figure1.1 has been proposed which can increase the output waveform's number of levels while lowering the number of levels in the input

waveform force gadgets [7]. Thus the exchanging misfortunes are diminished accordingly the proficiency of the inverter increments. Numerous PWM strategies have been proposed for acquiring wanted flight of stairs output waveform from the different DC input voltage sources and they are sinusoidal pulse.

LITERATURE SURVEY

Various mechanical applications have begun to require high power in recent years. A few machines in businesses, on the other hand, require medium or low force to operate. Using a powerful hotspot for all mechanical burdens may benefit certain engines that require a lot of force, but it could hurt other burdens. Medium voltage is required for several medium voltage engine drives and utility applications. Since 1975, the multilevel inverter has been offered as an alternative in high-force and medium-voltage applications. The Multilevel inverter looks like an inverter and is used for mechanical applications in high force and medium voltage situations as an alternative.

Multilevel inverters are three types.

- Diode clamped multilevel inverter
- Flying capacitors multilevel inverter
- Multilevel inverter with cascaded H-bridges

The hapless H-lady the capacitors and switches of a multilevel inverter are used to reduce the amount of parts required in each level. This geography is made up of a series of force transformation cells that can be easily scaled. A H-scaffold is a combination of capacitors and switches that provides separate DC voltage information for each H-connect. It consists of H-connect cells that may create three different voltages: zero, positive DC, and negative DC.

Multilevel inverters have been drawing in for the scholarly community just as a new decade's business for high-force and medium-voltage energy control Furthermore, compared to a proportionately evaluated two-level converter; they can blend traded waveforms with reduced levels of consonant twisting. The Multilevel System idea is utilized to diminish the symphonious mutilation without lowering the inverter's power output in the output waveform The primary geographies covered in this study are diode-clasped inverter (unbiased - point clipped), capacitor-cinched (flying capacitor), and fell. With independent dc sources, this is a multilevel system. This paper additionally presents the most applicable regulation strategies created for this group of converters: Multilevel sinusoidal pulse width tweak, multilevel specific symphonious disposal, and space - vector adjustment. Writers emphatically think that this overview article will be particularly useful to analysts in locating important references in the field of geographies and regulation systems of multilevel inverter.

II. SOLARENERGY

Sustainable power can be named as exuberance from limitless regular assets. There are numerous wellsprings of common sustainable power asset like daylight; Water, air, biomass, and geothermal heat all provide heat.. Over a predetermined topographical territory, the degree and openings for environmentally friendly power assets are tremendous as opposed to different types of energy like petroleum products that are restricted and thought to explicit territories. With the quick

organization of sustainable power, proficiency, monetary advantages are enormous and would bring about huge energy security, while decreasing the natural impacts. This remembers positive advancements for improved medical services and decrease in newborn child death rates because of diminished contamination impact and nations would save millions on medical care [8]–[9]. Sustainable power regularly uproots show energy necessities in age of power, water warming, transportation, and energy administrations at provincial zones (off lattice).

Thusly, it can safely be anticipated that environmentally friendly power resources go probably as a stimulus to increase and improve energy access in provincial regions [10]. Sunlight based energy is saddled from the sun utilizing PV advancements, sun based warming, concentrated sun oriented force, thought photovoltaic's and are by and large portrayed dependent on the manner in which the energy is caught, changed over and disseminated. They are either delegated dynamic or latent. A PV structure changes over Using the photoelectric effect, light is converted into electrical energy. A variety of silicon semiconductors are used in the PV structure to collect photons and convert them to electrons. The generated DC is subsequently converted to AC using converters. As a result, using an explicit MPPT framework to magnify the energy captured from the sun is critical. The majority of this is accomplished by using sun-following PVs. The sun-following PVs achieve this goal by adapting to the global sun's insulation and intensifying the captured daylight radiation to create the most force at a constant voltage. The ability to convert light into energy is used to measure productivity in a solar-powered cluster, and it's an extremely important component in selecting the right board for the PV structure. Sunlight-based PVs can be efficiently integrated into the regular force supply as a reliable RE source. Nonetheless, there are various challenges in the sunlight-based energy system, such as the conflict between the PV-produced power and the interest.

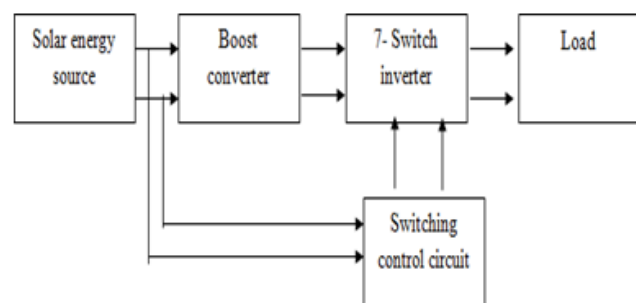

Figure 1: Proposed Block diagram

This is basically because of the stochastic age in PV. It prompts various different difficulties, and one such issue is voltage guideline. Contrasted and In comparison to other multilevel inverters, CMLI requires the most segments to get the same amount of voltage levels. The CMLI's only flaw is that it necessitates separate DC hotspots for genuine force changes. In any case, this disadvantage can be compensated by utilizing solar PV as a source of energy. Against this backdrop, the study explains how to reduce the complexity of the voltage controller control and increase power quality in a sunlight-based force circuit. The second section looks at various voltage control techniques. The recommended tactics for the proposed

structure are discussed in segment three, while the outcomes are examined in segment four, and the examination is concluded in segment five.

III CASCADED MULTILEVEL INVERTER FOR 15-LEVEL

Three PV sources are used in this multilevel inverter. For each switch, each source provides the needed voltage. The driving circuit requires 12 volts of power, whereas the inverter circuit requires 48 volts. The circuit of the inverter changes the current from DC over to AC. The PWM exchanging recurrence must be a lot higher than what might influence the heap (the gadget that uses the force), or, in other words that the subsequent waveform affirmed by the heap should be pretty much as even as could really be expected. The frequency (or repetition) with which the force supply should alter is adjustable contrast extraordinarily relying upon burden and application.

IV CONTROLLERMODELLING

The inverter tasks are indistinguishable and undifferentiated from a generator or a simultaneous machine to a network and most environmentally friendly power assets like sun based PV are associated with a Nintendo DS (Distribution System). Because the force produced in a PV varies due to light assimilation on the board, the assessed voltage can vary by 20% to 20% throughout the time of day Using force electronic circuits, it is feasible to maintain a constant DC voltage in the PV. The balanced out DC voltage is rearranged to AC because network voltage is conveyed in AC. In order to achieve precision for a 48V, 7A sun-powered board with a 20% variance, the suggested test uses an appropriate inverter with a maximum variation of 20%.

A. FUZZY LOGIC CONTROLLER

Lofti A. Zadeh outlined the fluffy logic, which is as follows: absolutely not quite the same as Boolean polynomial math. The innate qualities of fluffy rationale are the qualities state must be either 1 (ON) or 0 (OFF). The fluffy rationale shifts from the Boolean rationale because of its capacity to acknowledge at least two qualities between the valid and bogus. Not at all like the Boolean rationale has it acknowledged just evident or bogus. Fluffy rationale aids in the acquisition of fixed ends from ambiguous, unclear, and loose data.

Figure 2 shows the architecture of the Fuzzy Logic In a sun-based PV inverter with a falling H connect Multilevel inverter, a controller (FLC) was employed for VR. The output voltage (V_o) of a fifteen-level inverter is then compared to the reference voltage (V_{ref}), which is the voltage that the inverter should attain in order to meet the structure's specifications. For the subsequent blunder, the FLC receives information credits, $e = V_{ref} - V_o$, and the rate of mistake change changes de/dt . The FLC is made up of five important squares. Fuzzifier, defuzzifier, derivation structure, rule basis, and information base are the terms used to describe them. Enrollment capacity fuzziness affects the conversion of input data into participation levels. C_s , the FLC's ordering indication (or control signal), is then discriminated.

The ordering signal (or control signal) C_s of the FLC is then subtracted from V_{ref} to generate the regulating signal M_s

required for PWM generation, hence managing the cost of the proper gating signals to the semiconductor switches in the inverter power circuit. The problem is defined by a misstep and its subordinate MF (enrollment work). The MF for the blunder signal is shown in Figure 3. In this figure, N stands for Negative, P for Positive, and Z for Zero. Similarly, B stands for Big, M for Medium, S for Small, and E for Error.

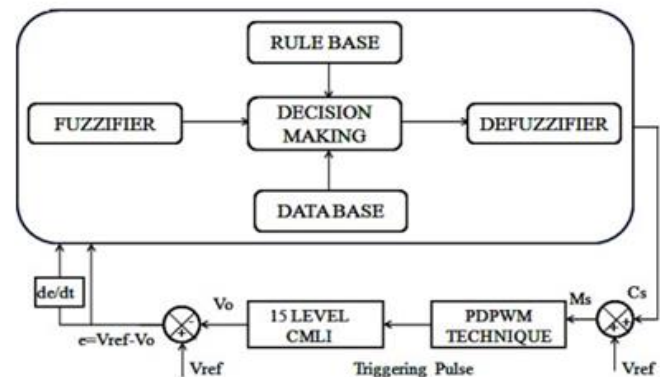

Figure 2: Fuzzy logic control structure.

Figure 4 shows the component of the mistake signal for the fluffy reasoning regulator information and its MF.

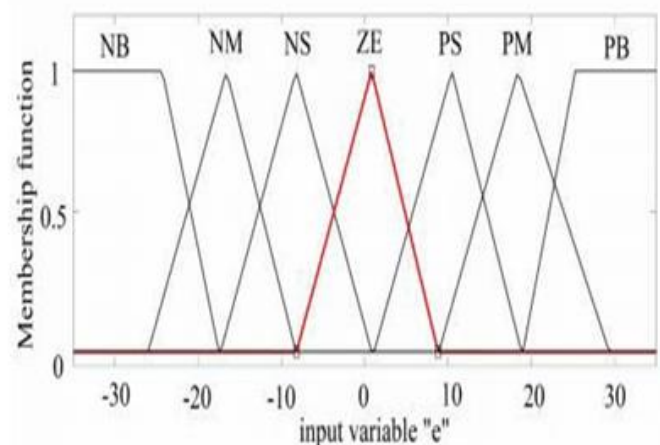

Figure 3: Membership function

The fluffy rationale as shown in Figure 4, the output is a reference signal shaped from a participation work.

TABLE 1
FLC rule matrix

e		NB	NS	NM	ZE	PB	PS	PM
C_e	NB	PB	PB	PB	PB	ZE	PM	PS
	NS	PB	PM	PB	PS	NM	ZE	NS
	NM	PB	PB	PB	PM	NS	PS	ZE
	ZE	PB	PS	PM	ZE	NB	NS	NM
	PB	ZE	NM	NS	NB	NB	NB	NB
	PS	PM	ZE	PS	NS	NB	NM	NB
	PM	PS	NS	ZE	NM	NB	NB	NB

There are two data sources (blunder and its subordinate sign) and one output (reference signal) in the typical table outlined generally speaking lattice appeared in Table 1. The fluffy worth is then changed over to fresh esteem utilizing a defuzzification system. The technique embraced for the transformation is Center of Gravity (COG).

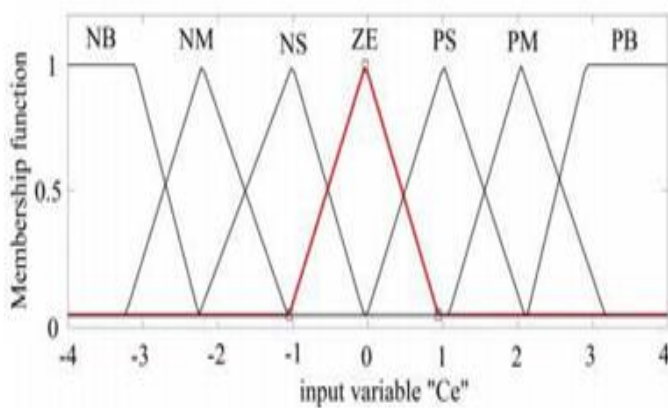

Figure 4: For a change in an error signal, use MF

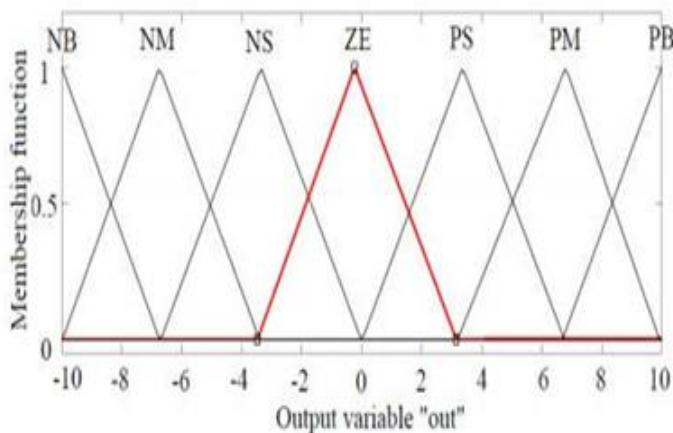

Figure 5: MF for the reference output

HARMONIC ELIMINATION FOR CASCADED MULTILEVEL INVERTER

To expand the nature of the output power it is important to lessen the music present in the output waveform. For decreasing the music numerous techniques have been proposed like Sinusoidal PWM, Space Vector PWM, space vector adjustment and particular symphonious disposal. Among those the best in disposing of the music is specific consonant end (SHE) technique. SPWM and space vector PWM are high recurrence exchanging strategies henceforth these sorts of procedures causes high exchanging misfortunes and furthermore requires huge channels, though the SHE is low recurrence exchanging technique so the exchanging misfortunes will be less. This sort of the adjustment control method will restrict the consonant substance in the output voltage signal

SIMULATION ANDANALYSIS

Multilevel converters have a few DC connects to allow for autonomous MPP following and control of possible voltage at each string. An open-circle construction driven by the sun takes care of a 15-level inverter without VR. Boards with varying levels of irradiance are planned and associated with each of the CMLI phases. Seven fallen H-spans are related in arrangement with the fifteen levels. A reference and transporter signal is evaluated for the beat age. For the creation of a heartbeat signal, the reference sinusoidal and the three-sided transporter are considered. For pulse generation, the bipolar PDPWM method is used.

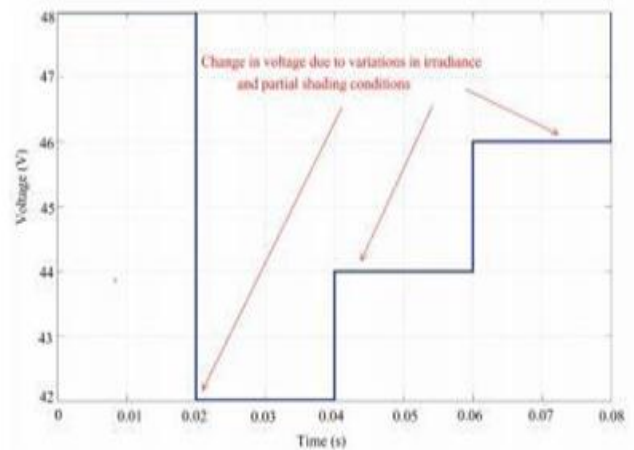

Figure 6: Changes in output voltage as a function of irradiance

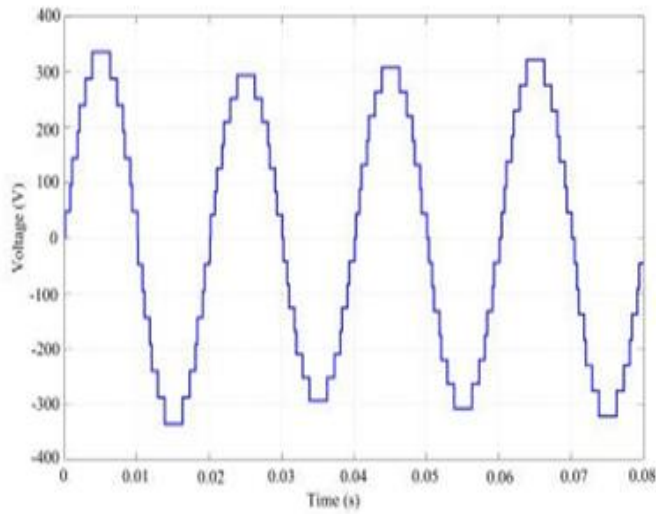

Figure 7: Variable irradiance output voltage with fifteen levels

Three-sided wave and positive sinusoidal sign are examined in one leg, while three-sided wave and negative sinusoidal sign are examined in the other leg for beat arrangement. Figure 5 depicts the modification in an inverter output voltage by exhibiting a PV board with various irradiance levels. Figure 6 depicts the output voltage waveform obtained as a result of irradiance variations and half-hidden states of sun-oriented PV modules. This results in an unbalanced appropriation of output voltage, resulting in voltage irregularities. These unequal developments can be redressed by embracing VR techniques.

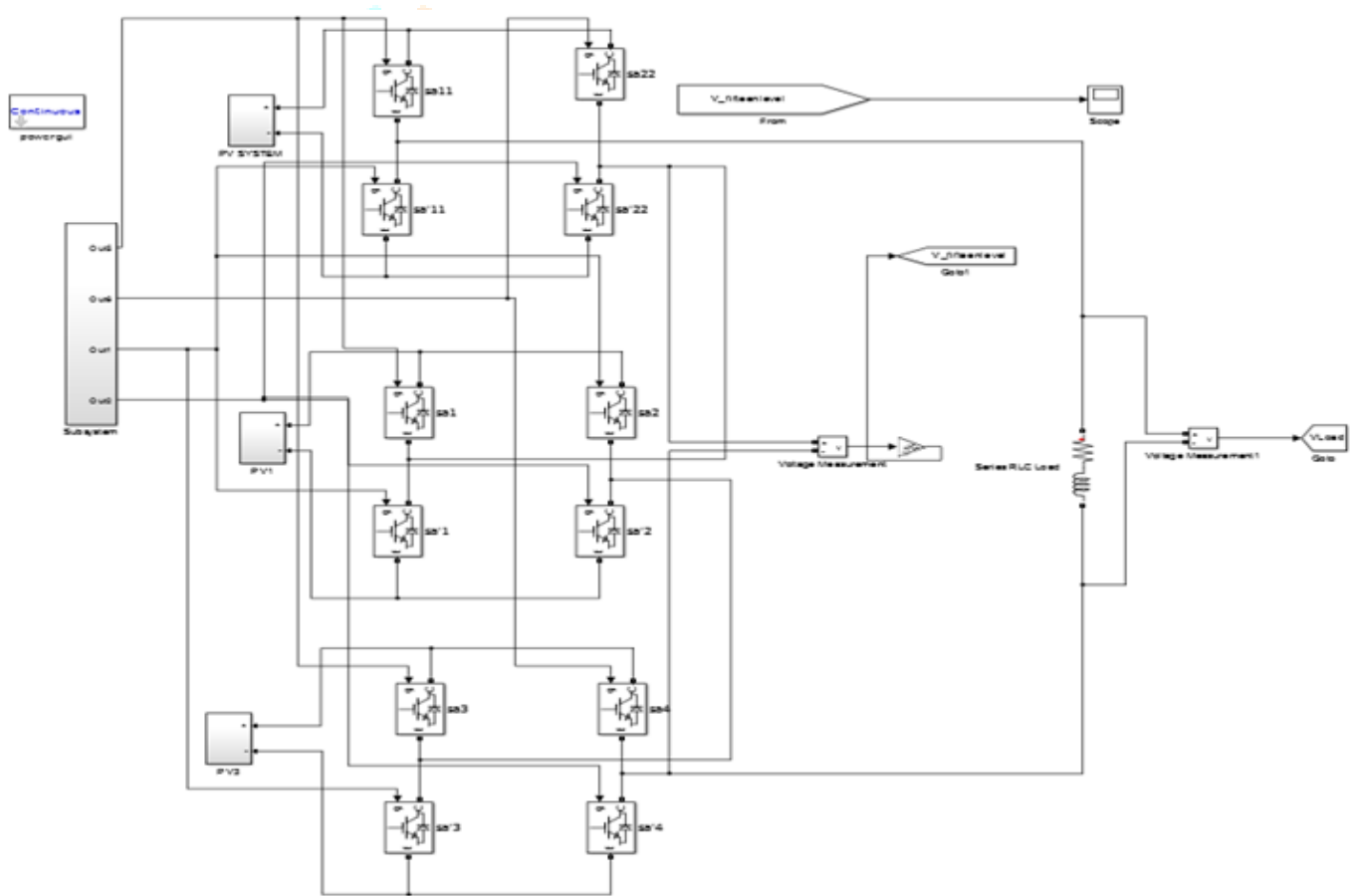

Figure 8: Simulated circuit of proposed 15 level inverter topology

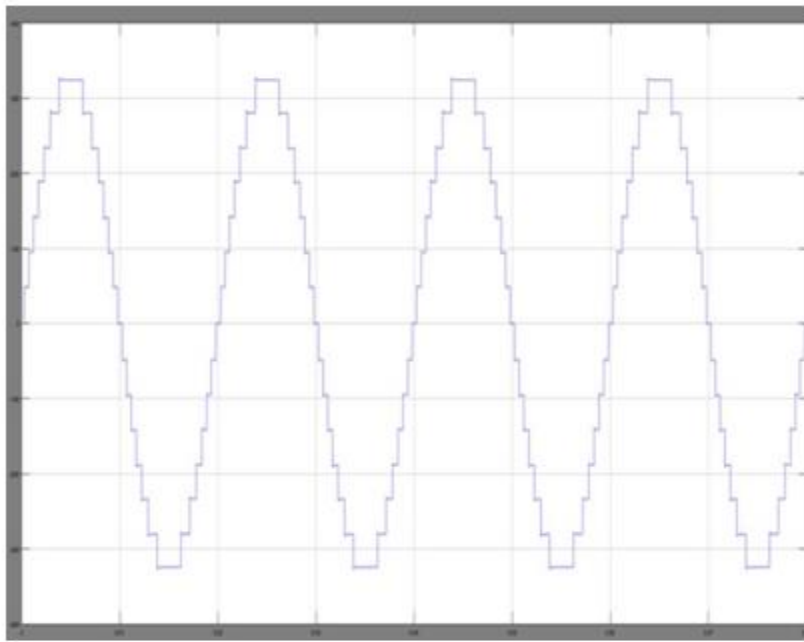

Figure 9: With FLC, you can have regulated Fifteen Level Output Voltages

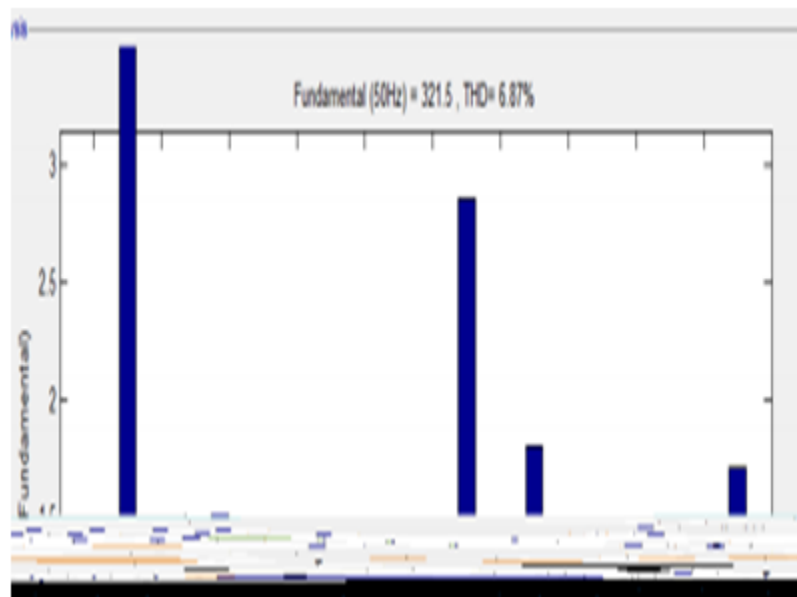
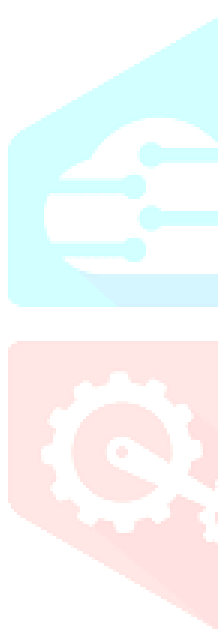

Figure 10: FFT analysis for voltage regulation based on FLC

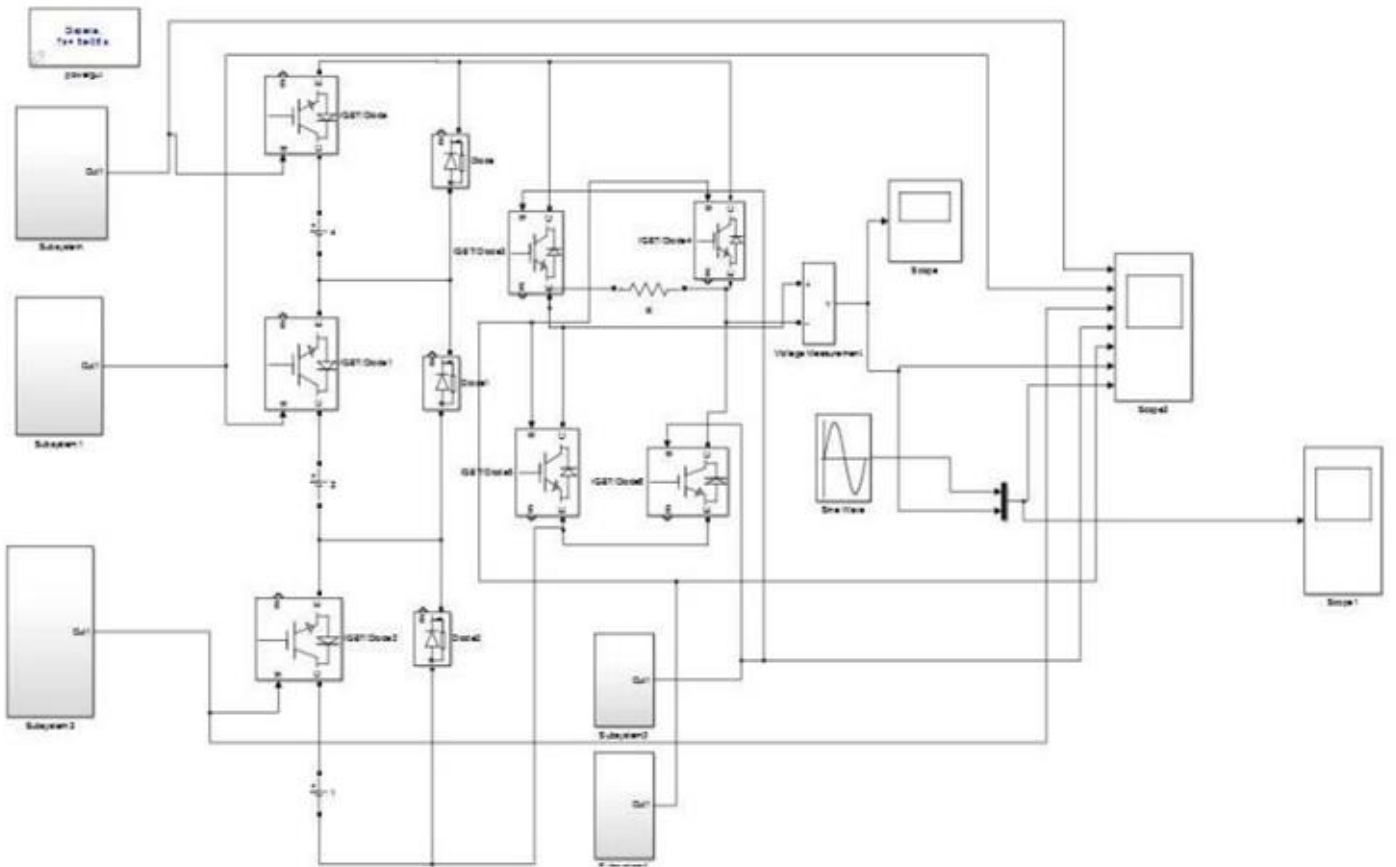
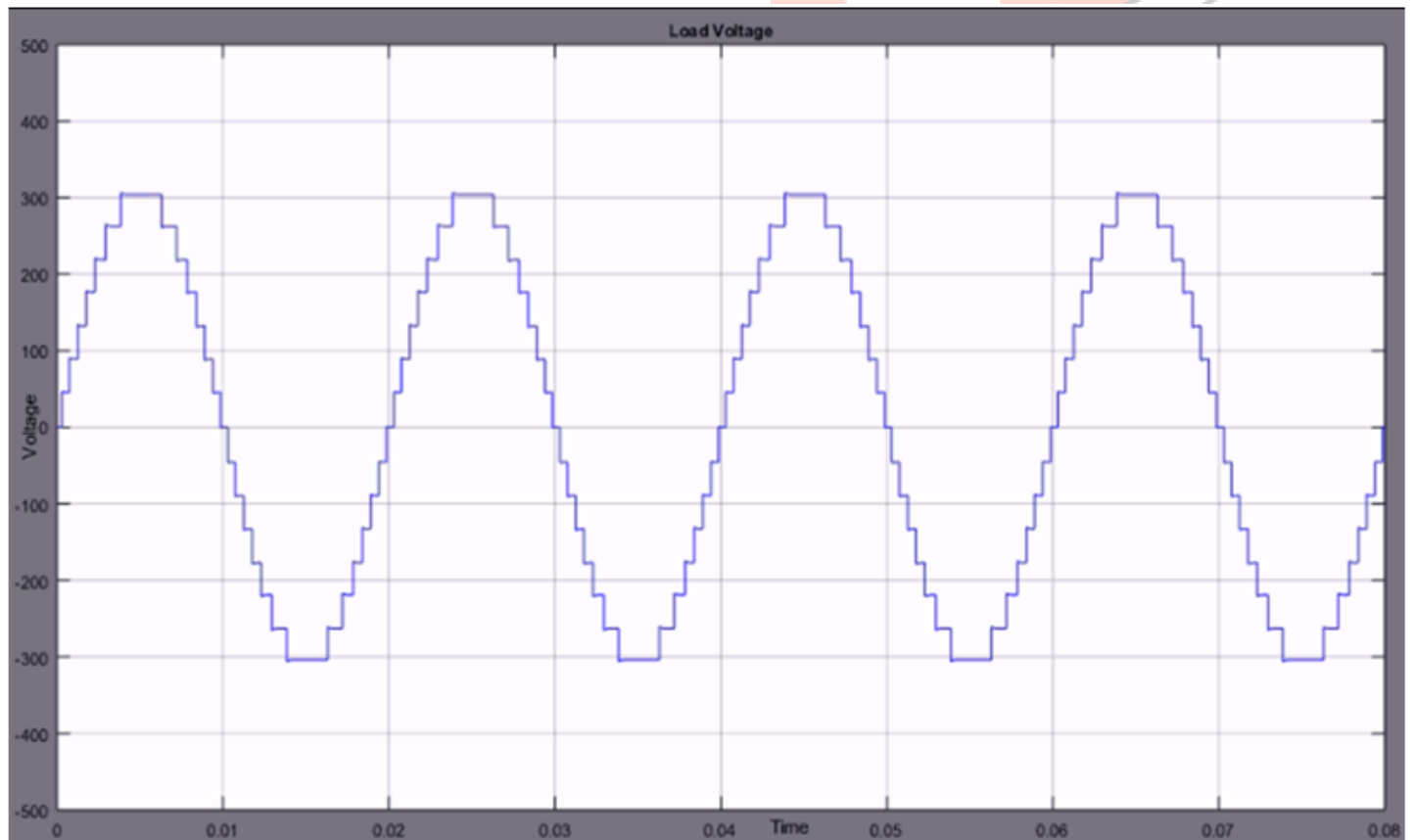
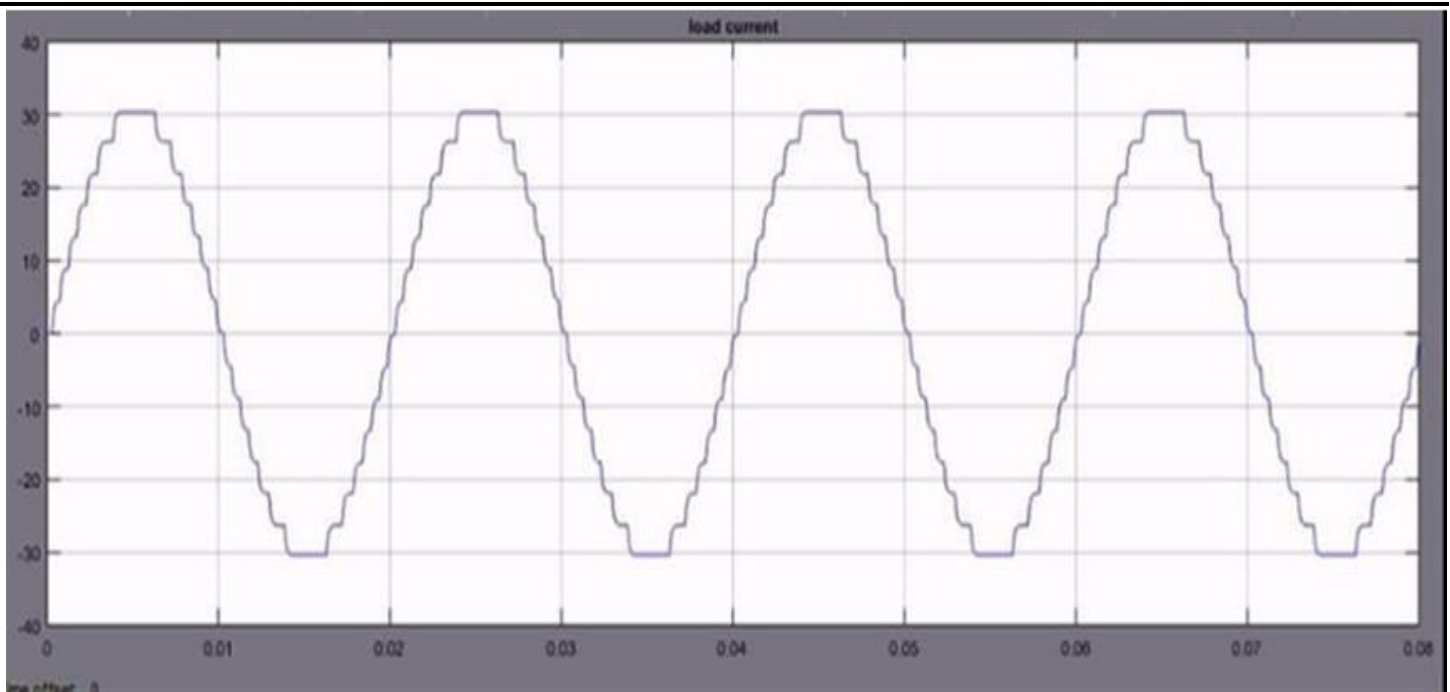

Fig 11 Simulated circuit of proposed 15 level inverter topology



(a) Load voltage



(b) Load current

Figure 12 simulation results of 7- switches

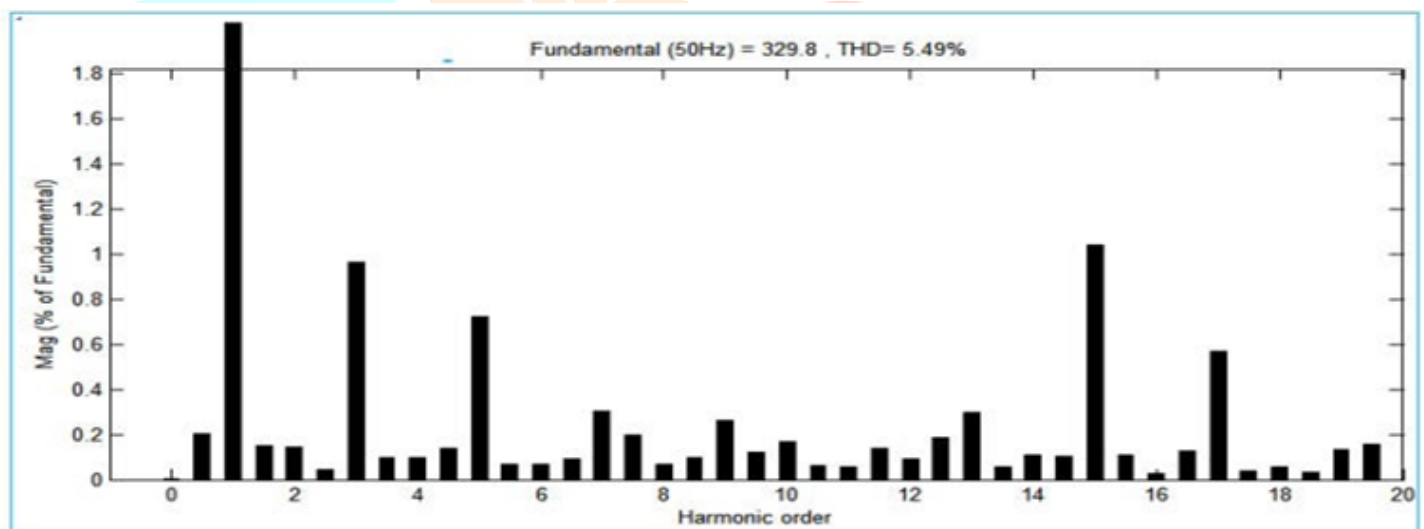

Figure 13: FFT study of voltage regulation based on 7 switches

Fuzzy derivation is used to make the option and create the example. The two sources of information flags are the blunder and derivate mistake signal, both of which are presented as participation labour. The regulator employs three-sided involvement work. The PWM generator receives an adjusting output signal from the participation work. Both the blunder and the secondary blunder have seven participation capacities each. For a better voltage guidance, about 49 concepts are outlined and used. Figure 12(a) shows the controlled output voltage, while Figure 13 shows the related FFT analysis. The similar investigation of the reenactment results acquired from the various techniques for 7-Switch Multilevel inverter is gotten.

CONCLUSION

The issue of FLC in Multilevel inverters has been explored in this paper. Diverse significant tackling approaches which are: PI and FLC have been thought of and are applied on a h-connect 15 level cross breed Multilevel inverter. While thinking about the outcomes, it was discovered that FLC produces better VR results while considering the various information sun-powered PV systems. The wide range of various techniques is executed for MLI geography with a low force and a lower degree of MLI is used in the business world because it provides a constant output voltage is examined; results demonstrate the adequacy of the proposed structure. The technique is pertinent for the clients require network collaboration alongside the force quality improvement. This geography gives an absolute consonant mutilation of 5.5% which is close to the IEEE norms and the air conditioner output voltage waveform nearly takes after a sine wave.

ACKNOWLEDGMENT

Narsimhareddy College of Engineering Research Centre, Jawaharlal Nehru Technological University, Hyderabad, funded this research.

REFERENCES

- [1] Nabae, I. Takahashi; H. Akagi. —A new neutral point-clamped PWM inverter, IEEE Trans. on Industry Applications, vol. 17, no.5, pp. 518- 523, 1981.
- [2] José Rodríguez “Multilevel Inverters: A Survey of Topologies, Controls, and Applications” Ieee Transactions On Industrial Electronics, Vol. 49, No. 4, August 2002.
- [3] Eswaramoorthy, K., and V. K. Shunmughanaathan. "A Simple And Geometry Based Fast Space-Vector Pwm Technique For 15 Level Cascaded Multilevel Inverter With Reduction Of Switches." Asian Journal of Research in Social Sciences and Humanities 6, no. 10 (2016): 2305-2320.
- [4] Eswaramoorthy, K., And Vk Shunmughanaathan. "Control Of Three Phase Four Wire Asymmetrical Fifteen Level Inverter Using Hybrid Bi-Tri Dimensional Space Vector Pulse Width Modulation." Journal Of Electrical Engineering 18, No. 4 (2018): 7-7.
- [5] Dhananjaya. Mudadla, Sandeep. N and G Rama rao “Novel Asymmetrical Multilevel Inverter Topology with Reduced Number of Switches for Photovoltaic Applications” 2015 International Conference On Computation Of Power, Energy, Information And Communication, 2015
- [6] Madhusudhana J, Sunilkumar and P S Puttaswamy “Genetic Algorithm Based 15-Level Modified Multilevel inverter For Stand Alone Photovoltaic systems” International Journal of Morden Trends In Engineering and Research (IJMTER) Vol. 03, Issue8, August 2016 ISSN(Online): 2349-9745, ISSN(Print): 2393- 8161.
- [7] Chatterjee, sayanti, k. Eswaramoorthy, b. Sindhu, and g. Chairenjevi. "an improved methodology for linear design of lateral autopilot incomplete state feedback controller using pole placement method." Control Engineering 7, no. 8: 9.
- [8] D. Carrington, Date Set for Desert Earth. London, U.K.: BBC News, 2000.
- [9] K. P. Schröder and R. C. Smith. (2018). Distant future of the Sun and Earth. <http://dx.doi.org/10.1111/j.1365-2966.2008.13022.x>
- [10] J. Palmer, “Hope dims that Earth will survive Sun’s death,” New Sci., Mar. 2008. [Online]. Available: <https://www.newscientist.com/article/dn13369-hope-dims-that-earth-will-survive-suns-death/>
- [11] R. Dash and S. C. Swain, “Effective power quality improvement using dynamic activate compensation system with renewable grid interfaced sources,” Ain Shams Eng. J., vol. 9, no. 4, pp. 2897–2905, Dec. 2018.
- [12] E. Hossain, M. R. Tur, S. Padmanaban, S. Ay, and I. Khan, “Analysis and mitigation of power quality issues in distributed generation systems using custom power devices,” IEEE Access, vol. 6, pp. 16816–16833, 2018.
- [13] M. Guerrero, and A. Al-Durra, “Cooperative control of Multi- Master-Slave islanded microgrid with power quality enhancement based on conservative power theory,” IEEE Trans. Smart Grid, vol. 9, no. 4, pp. 2964–2975, Jul.2018.
- [14] O. Lopez-Santos, C. A. Jacanamejoy-Jamioy, D. F. Salazar-D’Antonio, J. R. Corredor-Ramirez, G. Garcia, and L. Martinez-Salamero, “A single-phase transformer-based cascaded asymmetric multilevel inverter with balanced power distribution,” IEEE Access, vol. 7, pp. 98182–98196, 2019, doi: 10.1109/ACCESS.2019.2930230.
- [15] X. Guo, Y. Bai, and B. Wang, “A programmable single-phase multilevel current source inverter,” IEEE Access, vol. 7, pp.102417–102426, 2019, doi: 10.1109/ACCESS.2019.2931741.
- [16] M. D. Siddique, S. Mekhilef, N. M. Shah, and M. A. Memon, “Optimal design of a new cascaded multilevel inverter topology with reduced switch count,” IEEE Access, vol. 7, pp. 24498–24510, 2019, doi: 10.1109/ACCESS.2019.2890872.
- [17] Eswaramoorthy, K. "Study and performance analysis of hybrid bi tri dimensional space vector pulse width modulation for asymmetrical fifteen level inverter."
- [18] M. H. Mondol, M. R. Tur, S. P. Biswas, M. K. Hosain, S. Shuvo, and E. Hossain, “Compact three phase multilevel inverter for low and medium power photovoltaic systems,” IEEE Access, vol. 8, pp. 60824–60837, 2020, doi: 10.1109/ACCESS.2020.2983131.
- [19] M. D. Siddique, S. Mekhilef, N. M. Shah, J. S. M. Ali, M. Meraj, A. Iqbal, and M. A. Al-Hitmi, “A new single phase single switched-capacitor based nine-level boost inverter topology with reduced switch count and voltage stress,” IEEE Access, vol. 7, pp. 174178–174188, 2019, doi: 10.1109/ACCESS.2019.2957180.
- [20] M. M. Zaidand J.-S. Ro, “Switch ladder modified H-Bridge multilevel inverter with novel pulse width modulation technique,” IEEE Access, vol. 7, pp. 102073–102086, 2019, doi:10.1109/ACCESS.2019.2930720.
- [21] P. R. Bana, K. P. Panda, R. T. Naayagi, P. Siano, and G. Panda, “Recently developed reduced switch multilevel inverter for renewable energy integration and drives application: Topologies, comprehensive analysis and comparative evaluation,” IEEE Access, vol. 7, pp. 54888–54909, 2019, doi:

10.1109/ACCESS.2019.2913447.

- [22] P. Omer, J. Kumar, and B. S. Surjan, "A review on reduced switch count multilevel inverter topologies," *IEEE Access*, vol. 8, pp. 22281–22302, 2020, doi: 10.1109/ACCESS.2020.2969551.
- [23] C. Verdugo, J. I. Candela, and P. Rodriguez, "Energy balancing with wide range of operation in the isolated multi- modular converter," *IEEE Access*, vol. 8, pp. 84479–84489, 2020, doi:10.1109/ACCESS.2020.2992227.
- [24] D. Lyu, Y. Sun, C. A. Teixeira, Z. Ji, J. Zhao, and Q. Wang, "A modular multilevel dual buck inverter with adjustable discontinuous modulation," *IEEE Access*, vol. 8, pp. 31693–31709, 2020, doi:10.1109/ACCESS.2020.2972906.
- [25] E.-J. Lee, S.-M. Kim, and K.-B. Lee, "Modified phase-shifted PWM scheme for reliability improvement in cascaded H-Bridge multilevel inverters," *IEEE Access*, vol. 8, pp. 78130–78139, 2020, doi: 10.1109/ACCESS.2020.2989694.
- [26] A. Sabry, Z. M. Mohammed, F. H. Nordin, N. H. Nik Ali, and A. S. Al-Ogaili, "Single-phase grid-tied transformerless inverter of zero leakage current for PV system," *IEEE Access*, vol.8, pp. 4361–4371, 2020, doi: 10.1109/ACCESS.2019.2963284.
- [27] J. Selvaraj and N. A. Rahim, "Multilevel inverter for grid connected PV system employing digital PI controller," *IEEE Trans. Ind. Electron.*, vol. 56, no. 1, pp. 149–158, May2019.
- [28] A. Ghazanfari, H. Mokhtari, and M. Firouzi, "Simple voltage balancing approach for CHB multilevel inverter considering low harmonic content based on a hybrid optimal modulation strategy," *IEEE Trans. Power Del.*, vol. 27, no. 4, pp. 2150–2158, Dec.2012.

