



FUZZY IMPULSIVE INTEGRO DIFFERENTIAL EQUATIONS AND RULE BASED SYSTEM WITH MAMDANI'S MODEL

Author¹ Shaik Subhan- Scholar of Department of Mathematics at Sri Satya Sai University of Technology & Medical Science-Sehore-MP.

Author² Dr. Shahnawaz Ali- Associate Professor of Department of Mathematics at Sri Satya Sai University of Technology & Medical Science-Sehore-MP.

Abstract

Integral equations are a standout amongst the most helpful scientific instruments in both immaculate and connected Mathematics. They have huge applications in numerous real problems. Many starting and limit esteem problems related with ordinary differential condition (ODE) and partial differential condition (PDE) can be changed into problems of comprehending some surmised essential equations. There exists a broad hypothesis for impartial useful integro differential equations which incorporates subjective conduct of classes of such equations and applications to biological and designing procedures for subtleties. A fuzzy Inference system (FIS) maps fresh contributions to fresh yields. A FIS comprises of four segments: the fuzzifier, inference motor, rule base, and defuzzifier. We can say that Fuzzy logic ideas incorporate fuzzy sets, fuzzy logic administrators, rule-based frameworks, fuzzy maps, and derivation motor and defuzzification strategies. The utilization of fuzzy inference capacities is effectively taken care of even in state space; interestingly, all counts must be numerical and not diagnostic.

Keywords: *integro, differential, equation, mamdani's, model, fuzzy, etc.*

1. INTRODUCTION

Integral equations are a standout amongst the most helpful scientific instruments in both immaculate and connected Mathematics. They have huge applications in numerous real problems. Many starting and limit esteem problems related with ordinary differential condition (ODE) and partial differential condition (PDE) can be changed into problems of comprehending some surmised essential equations. For sure, demonstrating such problems utilizing fundamental equations with the correct parameters is simple as well as outlandish in the real problems. For this reason, one way is utilizing some vulnerability measures for dealing with such absence of data. A standout amongst

the most and late methodologies is utilizing Zadeh's fuzzy concept. In the recently portrayed (Mamdani) model, the whole information is subjective in light of the fact that we attribute a scope of truth esteems for every factor through the distinctive picked participation capacities.

1.1 Fuzzy Differential Equations

The investigation of fuzzy differential equations (FDE) structures a reasonable setting for mathematical modeling of real world problems in which vulnerabilities or dubiousness invades. Fuzzy

differential equations are a characteristic method to show dynamical frameworks under vulnerability. The idea of a fuzzy subsidiary was characterized by Chang and Zadeh. It was followed up by Dubois and Prade, who utilized the expansion guideline. The term fuzzy differential equation was presented by Kandel and Byatt. There have been numerous recommendations for the meaning of fuzzy subsidiary to ponder fuzzy differential equations.

The first and the most well-known methodology are utilizing the Hukuhara differentiability for fuzzy-esteem capacities. Under this setting, for the most part the presence and uniqueness of the arrangement of fuzzy differential equations are contemplated. This methodology has a disadvantage: the arrangement winds up fuzzier as time passes by. Consequently, the fuzzy arrangement carries on uniquely in contrast to the fresh arrangement. The idea of fuzzy subsidiary as an augmentation of the Hukuhara subordinate and fuzzy

indispensable, which was equivalent to what Dubois and Prade proposed

2. EXISTENCE AND UNIQUENESS RESULTS FOR FUZZY IMPULSIVE INTEGRO DIFFERENTIAL EQUATIONS

There exists a broad hypothesis for impartial useful integro differential equations which incorporates subjective conduct of classes of such equations and applications to biological and designing procedures for subtleties, however, the solid model is the radio cardiogram, where the two compartments relate to one side and right ventricles of the pneumatic and systematic flow. Funnels turning out from and returning into a similar compartment may speak to shunts, and the equation speaking to this model is nonlinear impartial volterra integro differential equations in. Hence, there has been an expanding enthusiasm for examining equations that can be portrayed in the structure

$$x'(t) = a(t)x(t) + \int_0^t k(t,s,x(s))ds + f(t,x(t)), \quad t \in J,$$

$$\Delta x|_{t=t_k} = I_k(x(t_k)), \quad k = 1, 2, 3, \dots, m,$$

$$x(0) = x_0,$$

Where x_t represents the history of x at t and $a: J \rightarrow E_N$ is a fuzzy co-efficient. E_N is the set of all upper semi-continuous, convex, normal fuzzy numbers with bounded α -level intervals,

3. FUZZY LOGIC BASED INFERENCE SYSTEM

A fuzzy Inference system (FIS) maps fresh contributions to fresh yields. A FIS comprises of four segments: the fuzzifier, inference motor, rule base, and defuzzifier. The fuzzifier maps information numbers into relating fuzzy enrollment esteems. The inference motor characterizes mapping from information fuzzy sets to yield fuzzy sets. It decides how much the precursor (ancestor) part is fulfilled for each

standard. In the event that the predecessor part of the standard has more than one proviso, fuzzy administrators are applied to get a number that speaks to the consequence of the forerunner part for that standard. Yields of all guidelines are then collected. The defuzzifier maps the yield fuzzy sets into a fresh number. The for the most part utilized defuzzification strategy is the centroid technique.

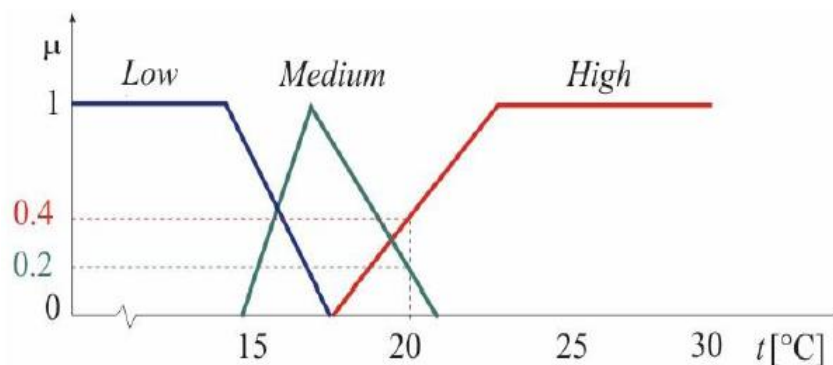

Figure 1: A Choice of Membership Functions for a Variable “Temperature”.

In designing a FIS we need fuzzy rules. Regularly, these rules are gotten from master's learning. Be that as it may, it is likewise conceivable to create fuzzy rules from test information focuses. Wang and Mendel (1991) have proposed a systematic strategy for extricating fuzzy rules from test information focuses.

The semantic rules are utilized to characterize the connection between the info and the yield, yet how precisely are the yield fuzzy qualities decided? There are a few different ways to decide the appropriate response dependent on the sources of info, predominantly the Mamdani, Larsen, Takagi-Sugeno-Kang, and Tsukamoto inference and conglomeration strategies. Right off the bat, we should depict the essential general set of rules, they will be a set of rules that have one contribution to a fuzzy set and one yield in a fuzzy set.

If x is A_i then y is B_i , $i=1,2,\dots,n$

Let us look at a system that has two input membership functions (A_1, A_2) and two output membership functions (B_1, B_2). These membership functions, shown below (Fig.1 a & b), define the fuzzy sets A and B in the above general inference rule.

If $(x_1 \text{ is } \tilde{A}_1, x_2 \text{ is } \tilde{A}_2, \dots, x_n \text{ is } \tilde{A}_n)$ Then $(y_1 \text{ is } \tilde{B}_1, y_2 \text{ is } \tilde{B}_2, \dots, y_n \text{ is } \tilde{B}_n)$.

Where linguistic variables x_i, y_j takes values of fuzzy sets A_i and B_j respectively

- Example:**

If there is heavy rain and strong winds then

A_1 and A_2 are shown on the left, with A_1 in blue and A_2 in green. On the right B_1 is blue and B_2 is green. We will be using the Mamdani inference model to combine the sets and rules. If the input value has membership in a function, then any rule using that membership function is said to 'fire' and produce a result. These results are then aggregated using the Mamdani model (or a different model).

4. FUZZY RULE BASED SYSTEM MAMDANI'S MODEL

Fuzzy linguistic descriptions are formed representations of systems made through fuzzy IF-THEN rules.

In the simple one input and one output example given in fig.2, the rules were simply that if input is low output is low and if input is high output is high.

If (a set of conditions) as satisfied THEN (a set of consequents) can be inferred

If - then rules are coded in the form. In a multi input system, the input vector has values for x_1, x_2, \dots, x_n . The membership functions are designated as A_1, A_2 etc. Then,

there must be severe flood warning.

Here, heavy, strong and severe and fuzzy sets qualifying the variables rain, wind and flood warning respectively. Using If-Then type fuzzy rules converts the fuzzy input to the fuzzy output (figure 2).

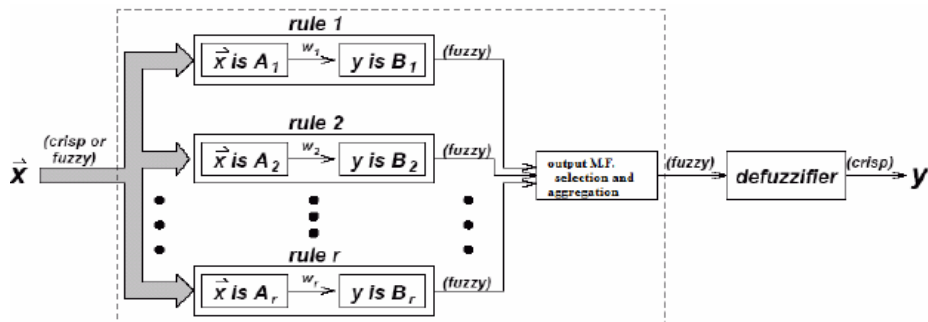

Figure 2 A Fuzzy Rule Based Inference System

5. TAKAGI-SUGENO MODIFICATION TO MAMDANI'S MODEL

In 1985 and later in 1988, Takagi, Sugeno and Kang delivered an altered fuzzy inference system for the Mamdani's model. In the recently portrayed (Mamdani) model, the whole information is subjective in light of the fact that we attribute a scope of truth esteems for every factor through the distinctive picked participation capacities. Likewise, for the yield required, we attribute a set of enrollment works over the range estimation of the yield variable. Hence, given a subjective set of information, for example, given in the table underneath, one can totally recommend a Fuzzy model of the system.



Table 1 A Fuzzy Inference System of Mamdani– Baby Nutrition Example

Height of a Baby (within one year)	Weight of Baby	Prescribed nutrition value per meal
Low (0 – 30 cm)	Light (1-2 kg)	High (150-250 mg)
Normal (20- 70 cm)	„	Normal (75-125 mg)
Tall (60- 100 cm)	„	Low (50-100 mg)
Low	Normal (1.5 -2.5 kg)	Low
Normal	„	Normal
Tall	„	High
Low	Weighty (2.0-4 kg)	Normal
Normal	„	High
Tall	„	High

Fuzzy logic has the capacity to mirror the human personality to successfully reason out from realities of perception, regardless of whether such actualities are estimated rather than precise. In spite of the fact that there are significant territories of cover between neural systems, Fuzzy logic, and probabilistic thinking, when all is said in done they are complimentary as opposed to focused. There are numerous approaches to combine neural systems and Fuzzy logic methods.

6. CONCLUSION

We can say that Fuzzy logic ideas incorporate fuzzy sets, fuzzy logic administrators, rule-based frameworks, fuzzy maps, and derivation motor and defuzzification strategies. The utilization of fuzzy inference capacities is effectively taken care of even in state space; interestingly, all counts must be numerical and not diagnostic. Fuzzy logic is currently genuinely settled in different fields and state space control is a typical method for ideal procedure control. In the recently portrayed (Mamdani) model, the whole information is subjective in light of the fact that we attribute a scope of truth esteems for every factor through the distinctive picked participation capacities. The vast majority of the pages here have recently presented these extremely same techniques.

REFERENCES

1. Nieto, JJ, Khastan, A &Ivaz, K 2009, ‘Numerical solution of fuzzy differential equations under generalized differentiability’, Nonlinear Analysis: Hybrid systems, vol. 3, pp. 700-707.
2. AkbarzadehGhanaie, Z &MohseniMoghadam, M 2011, ‘Solving fuzzy differential equations by Runge-Kutta method’, The Journal of Mathematics and Computer Science, vol. 2, no. 2, pp. 208-221.
3. Omar Abu-Arquab, Ahmad El-Ajou, ShaheerMomani& Nabil Shawagfeh2013, ‘Analytical Solutions of Fuzzy Initial Value Problems by HAM’, Applied Mathematics and Information Sciences, vol. 7, no. 5, pp. 1903-1919
4. Allahviranloo, T, Abbasbandy, S, Ahmady, N &Ahmady, E 2009, ‘Improved predictor-corrector method for solving fuzzy initial value problems’, Information Sciences, vol. 179, pp. 945-955.

5. OmidSoleymanifard&NimaGhal-Eh 2011, 'Numerical Solutions for linear system of first-order fuzzy differential equations with fuzzy constant coefficients', Information Sciences, vol. 181, pp. 4765-4779.
6. Prakash, P &Kalaiselvi, V 2012, 'Numerical Solutions of Fuzzy Differential Equations by Using Hybrid Methods', Fuzzy Information Engineering, vol. 4, pp. 445-455.
7. SoleymaniFard, O &VahidianKamyad, A 2011, 'Modified K-step method for solving Fuzzy Initial Value Problems', Iranian journal of Fuzzy Systems, vol. 8, no. 1, pp. 49-63.
8. Dahaghin, M, Sh&MohseniMoghadam, M 2010, 'Analysis of a twostep method for numerical solution of fuzzy ordinary differential equations', Italian journal of pure and applied mathematics, vol. 27, pp. 333-340.
9. BaloochShahryari, MR &Salashour, S 2012, 'Improved predictor corrector method for solving fuzzy differential equations under generalized differentiability', Journal of Fuzzy Set Valued Analysis,doi:10.5899/2012/jfsva-00121.
10. OmidSoleymanifard&NimaGhal-Eh 2011, 'Numerical Solutions for linear system of first-order fuzzy differential equations with fuzzy constant coefficients', Information Sciences, vol. 181, pp. 4765-4779.
11. Akin, O, Khaniyev, T, Oruc, O &Turksen, IB 2013, 'An algorithm for the solution of second order fuzzy initial value problems', Expert Systems with Applications, vol. 40, no. 3, pp. 953-957

