



# DESIGN OF RCC RESIDENTIAL BUILDING

**AMIR JAFRI.**

(Assistant professor)

Department of civil engineering  
Galgotias University

**REKHANKAN LAMA**

Department of civil engineering  
Galgotias University

**SURAJ KUMAR MANDAL**

Department of civil engineering  
Galgotias University

**VIVEK TOMAR**

Department of civil engineering  
Galgotias University

## ABSTRACT:

In today's world of development, people like to live in an environment of peace along with facilities whether assurance of safety and comfort is around.

Structural designing and planning for better serviceable and durable structure, this whole thing needs proper idea and concept as well as knowledge of practical feature. For this process selecting a good site for the building which includes bedroom, hall, kitchen, toilet, living room, and storeroom.

The offer dwelling building is designed and can be constructed at Goldhunga, Kathmandu, Nepal. The area of the proposed building is 607.14 sq feet. It will be a G+2 building.

The analysis of the body to evaluate the force and moment will be accomplished with ETABS software. The analysis of the structure was complete according to IS code 456:2000 of practice for plain and reinforced cement concrete.

With the limit state method of National building code & IS 456:2000 grade concrete, the structural parts like columns, beams, footing, footings, slabs, and staircase are designed.

In this project designing a water tank is also included.

Index terms – Structural elements, ETABS, AutoCAD, Building, Analysis, Design.

## INTRODUCTION

Everyone in this world wants to live in a peaceful environment with all the facilities, this feat is gained by the suitable location whether no sign of natural calamities. For that kind of resident place must include;

- >Peaceful environment
- >Safety from all-natural resources and climate conditions
- > All essentials facilities for the community of that residential area.

Consideration of the municipal rules, laws for making building, water supply, economical capacity, management of sewage, nature, supplies for future, air movement, ventilation, etc.

## RESIDENTIAL BUILDING;

The structure which gives additionally half of its floor area for residence reason. To put it another way, a dwelling building provides sleeping lodging with or without cooking or dining, or both provisions. The premises comprise rooms like bed, kitchen, hall, toilet, and bathroom.

## OBJECTIVES

- To provide all facilities for the residential building, this includes bedroom, hall, and balcony, and toilet, staircase with the passage, path and window and doors with the proper specification.
- To provide a building full of aimed facilities.
- To provide a secure and pleasant building for living.

## METHODOLOGY

During our work we were able to do the analysis;

### -Architectural Drawing

> In this part, we measure the area of the site and propose the area of the building

By considering the municipality rules. Then, we draw the architectural drawings of the residential building which include Floor plans, sections, and elevations according to the need and liking of the client with the help of Auto CAD.

### -Analysis

> This is the crucial part of building design as in this part, we analyze the forces and moments acting on the structures of the building. This analysis is done on the building with the help of ETABS software as according to IS code 456:2000 of practice for plain and reinforced cement concrete.

### -Structural Drawings

> In this step, we use resultant forces that we get from the analysis of the building to design the structural aspects of the building such as columns, beams, footings, and slabs.

## RESULTS, ANALYSIS, AND INTERPRETATION

### ARCHITECTURAL DRAWING;

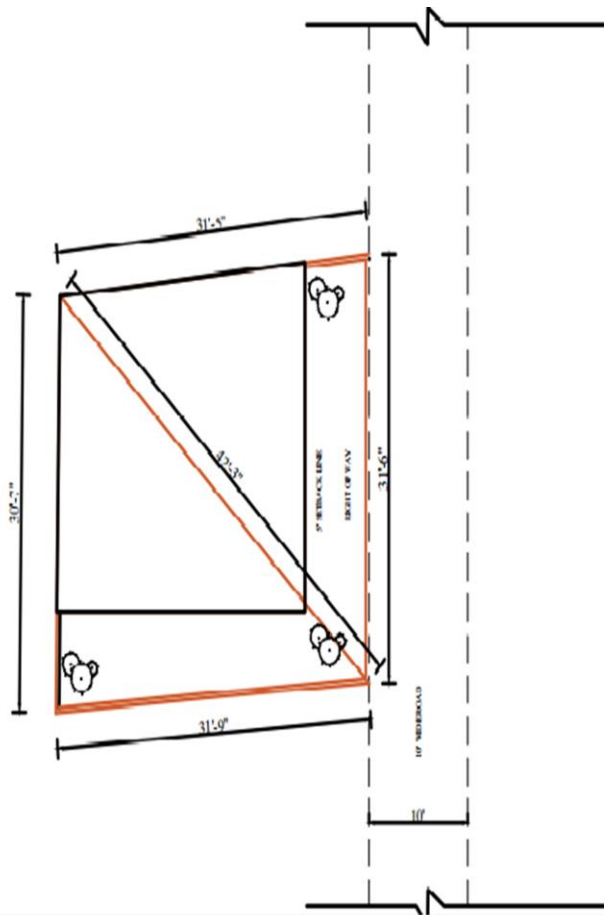

Site Plan

Area of site=976.21 sq ft

**ARCHITECTURAL DRAWING;**

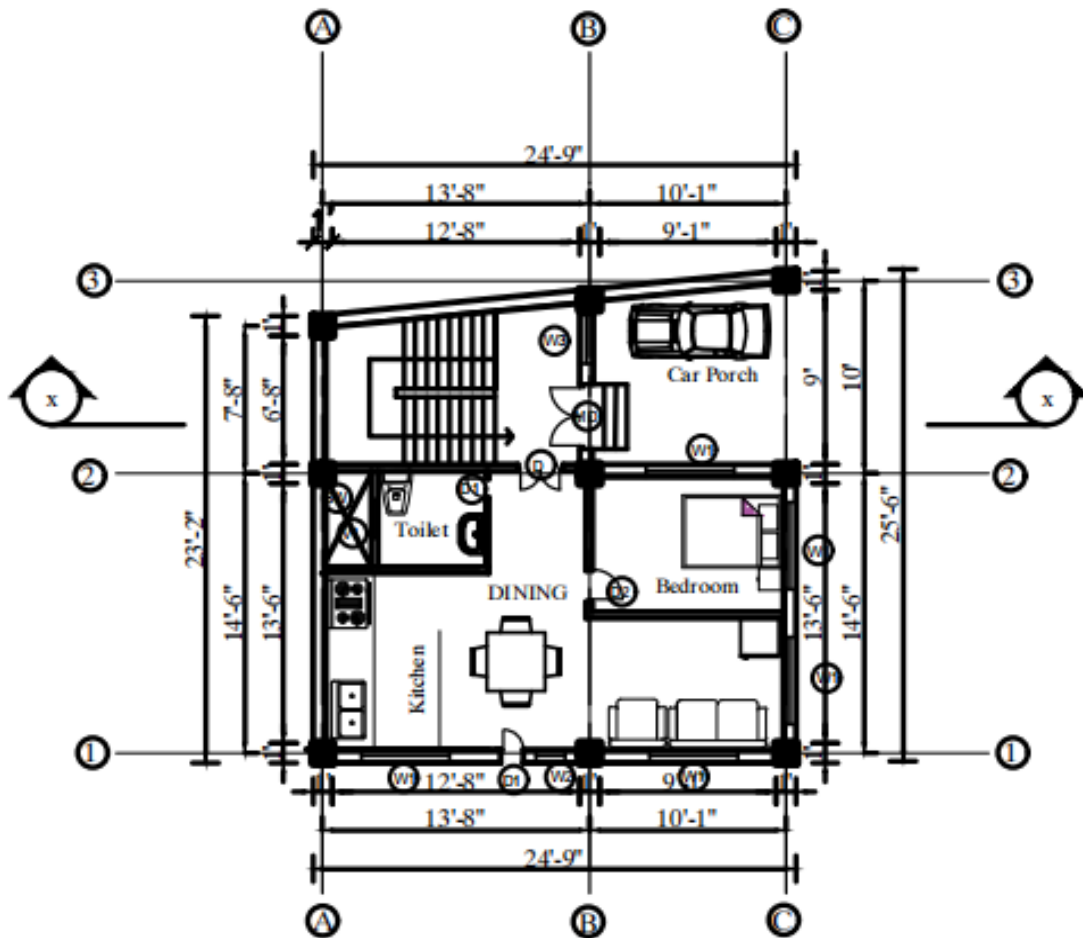

**GROUND FLOOR PLAN**

**Area of proposed building = 607.14 sq.ft**

**Area of proposed building = 62.1% of the area of site plan**

**Within municipality rule**

### ARCHITECTURAL DRAWING;

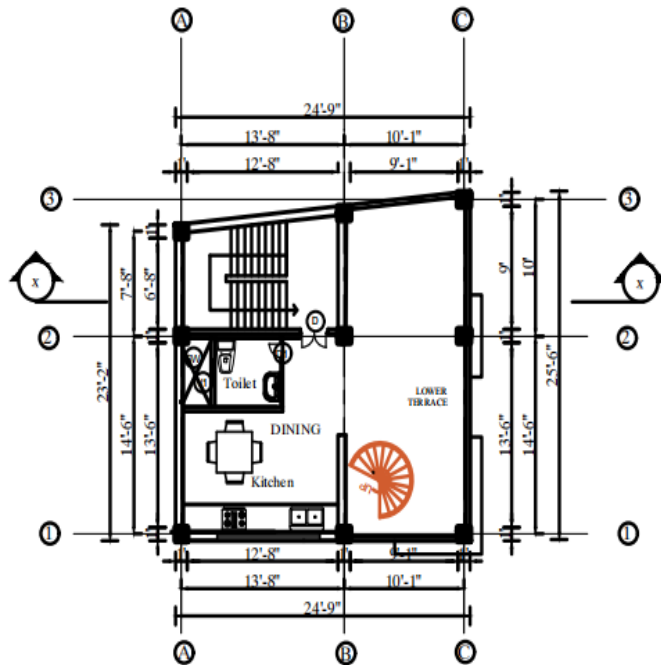

SECOND FLOOR PLAN  
AREA=607.14 square feet

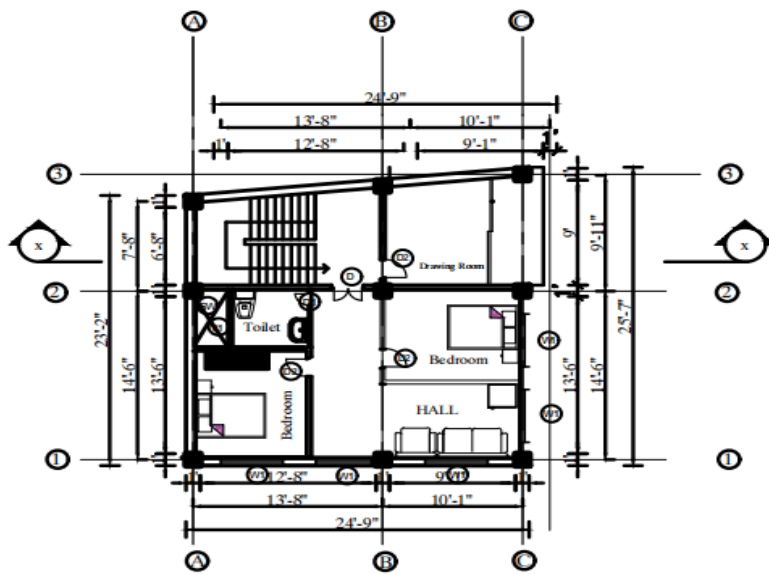

FIRST FLOOR PLAN  
AREA=607.14 square feet

### ARCHITECTURAL DRAWING;

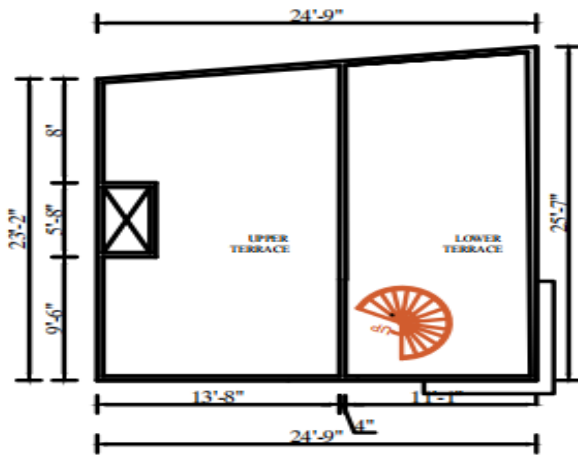

TERRACE FLOOR PLAN  
AREA=607.14 square feet

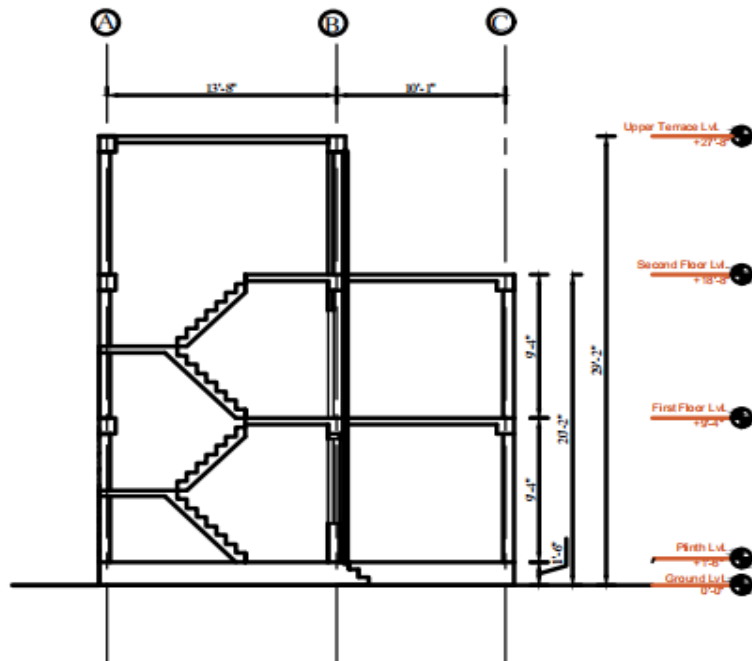

SECTION AT X-X

# ARCHITECTURAL DRAWING;

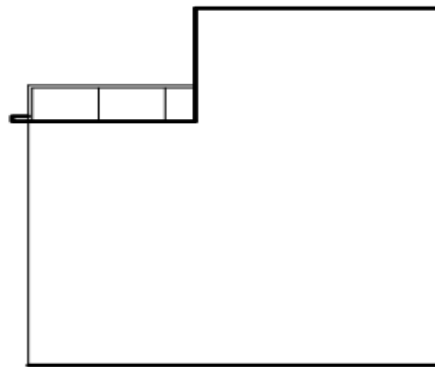

NORTH ELEVATION

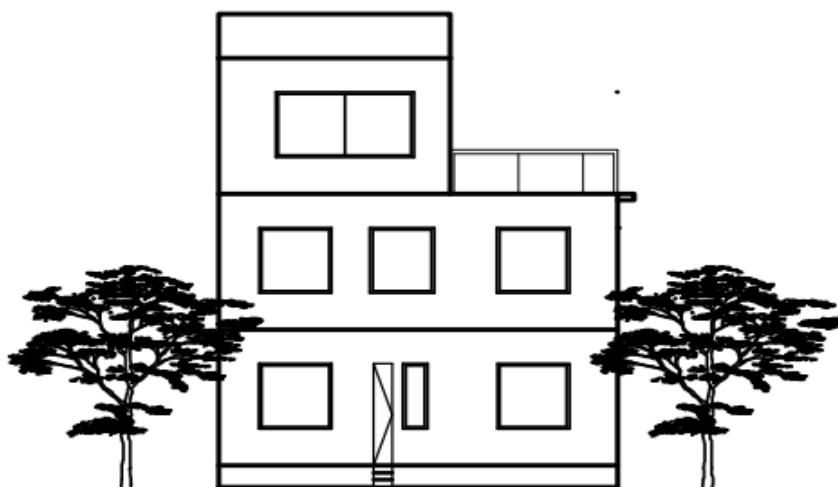

SOUTH ELEVATION

IJCRT

**ARCHITECTURAL DRAWING;**

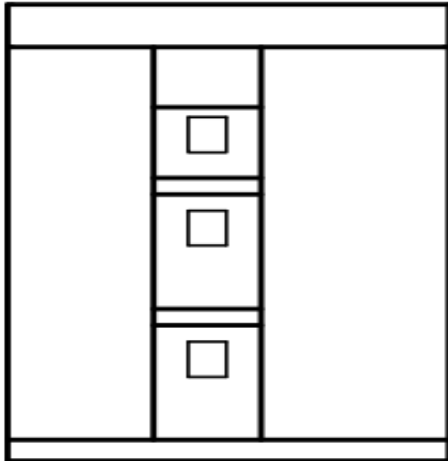

WEST ELEVATION

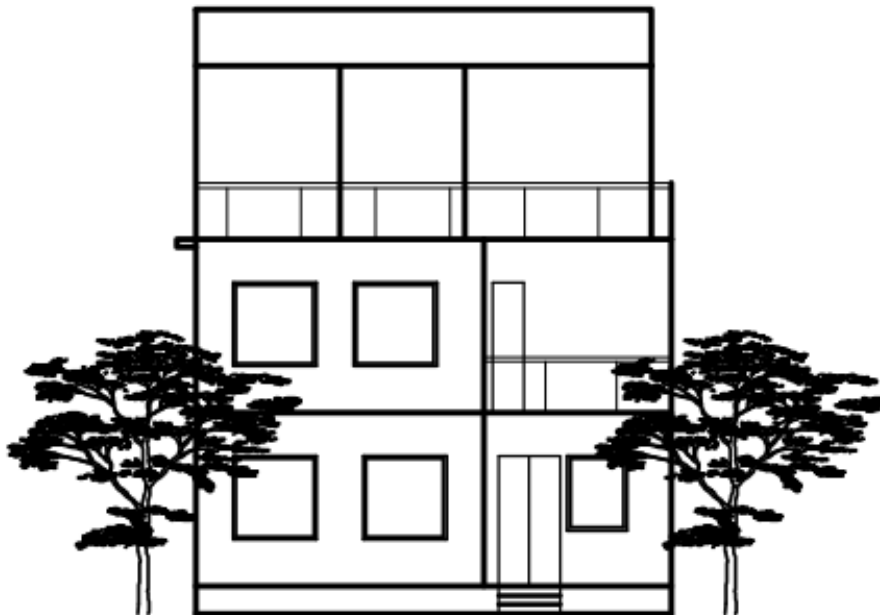

EAST ELEVATION



### STRUCTURAL ANALYSIS;

In this part, what we did was model the building in the ETABS software.

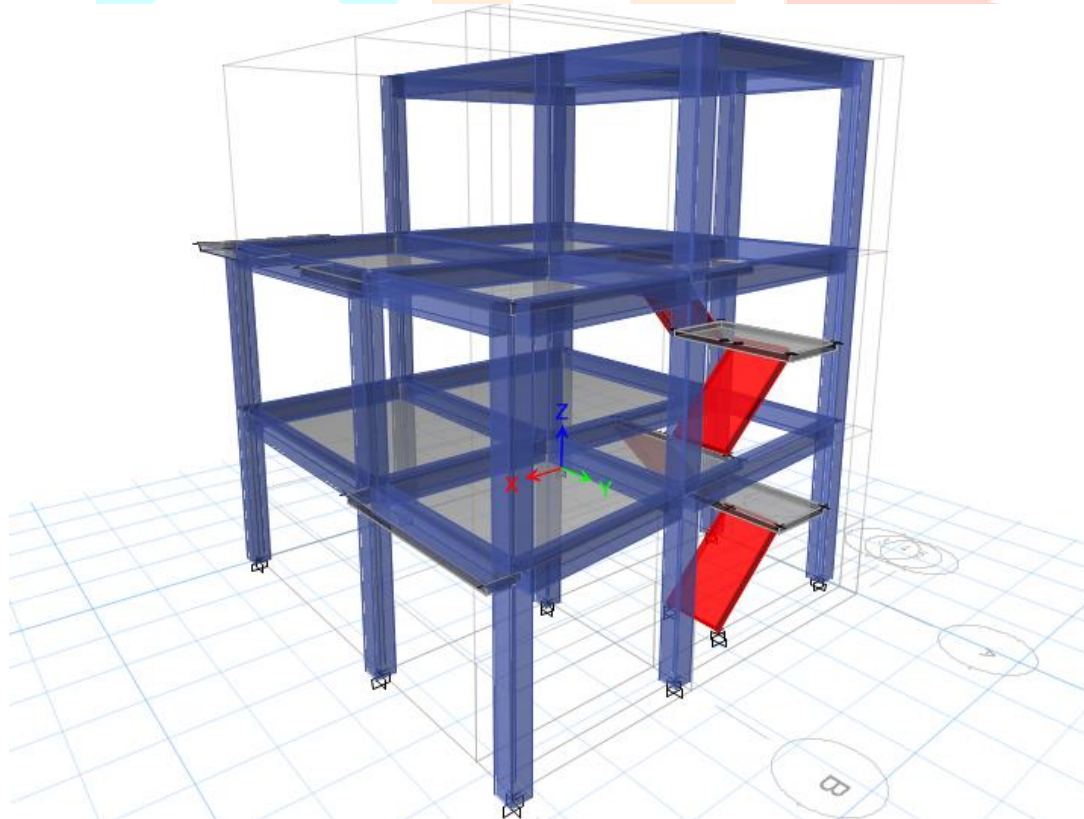
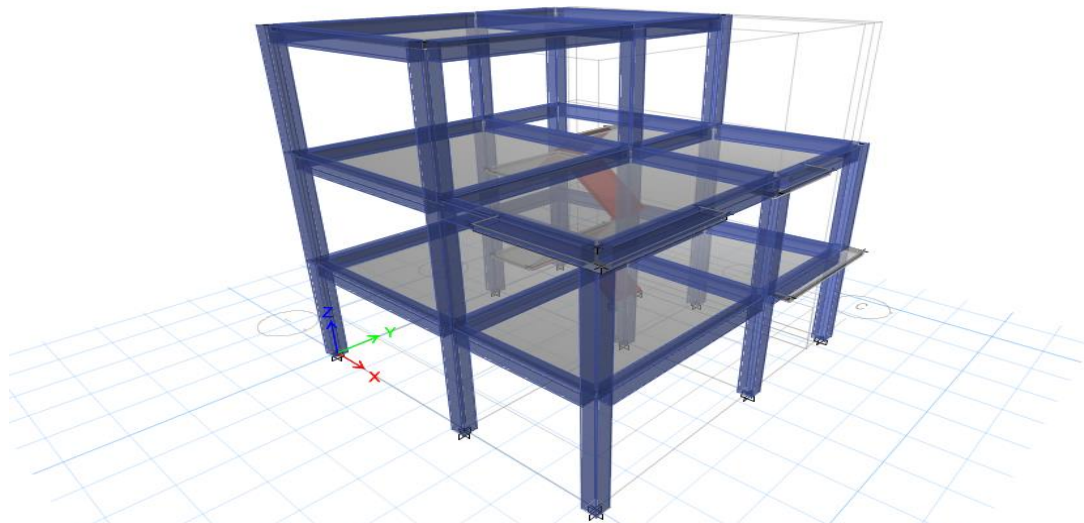

## STRUCTURAL ANALYSIS;

Then, we applied the loads to the structures of the building. Load such as:

- Live load (2.0 as per IS 456:2000 for residential building)
- Dead Load
- External wall load
- Internal wall load
- Partition wall Load
- Parapet load
- Water Tank Load
- Staircase Load
- Floor Finish
- Roof Live load
- Earthquake load at x-direction
- Earthquake load at y-direction

After, assigning the load on the structures, we analyzed the model. We considered the seismic reaction, base reaction, and modal participating mass ratios. What we found was the building was safe considering all those factors. The results are given below:

### I) Auto Seismic;

	A	B	C	D	E	F	G	H	I	J	K	L	M	N	O	P	Q	R	
1	TABLE: Auto Seismic- IS 1893:2002																		
2	Load Pattern	Type	Direction	Eccentricity	Ecc. Overridden	Period Method	Ct	Top Story	Bottom Story	Z Type	Z	Soil Type	I	R	Period Used	Coeff Used	Weight Used	Base Shear	
3				%			m								sec		kN	kN	
4	EQX	Seismic	X			Program Calculated		Story3	Base	Per Code	0.36	II		1	5	0.444	0.09	1717.2858	154.5557
5	EQX	Seismic	Y			Program Calculated		Story3	Base	Per Code	0.36	II		1	5	0.39	0.09	1717.2858	154.5557
6	EQX	Seismic	X + Ecc. Y	5	No	Program Calculated		Story3	Base	Per Code	0.36	II		1	5	0.444	0.09	1717.2858	154.5557
7	EQX	Seismic	Y + Ecc. X	5	No	Program Calculated		Story3	Base	Per Code	0.36	II		1	5	0.39	0.09	1717.2858	154.5557
8	EQX	Seismic	X - Ecc. Y	5	No	Program Calculated		Story3	Base	Per Code	0.36	II		1	5	0.444	0.09	1717.2858	154.5557
9	EQX	Seismic	Y - Ecc. X	5	No	Program Calculated		Story3	Base	Per Code	0.36	II		1	5	0.39	0.09	1717.2858	154.5557
10	EQY	Seismic	X			Program Calculated		Story3	Base	Per Code	0.36	II		1	5	0.444	0.09	1717.2858	154.5557
11	EQY	Seismic	Y			Program Calculated		Story3	Base	Per Code	0.36	II		1	5	0.39	0.09	1717.2858	154.5557
12	EQY	Seismic	X + Ecc. Y	5	No	Program Calculated		Story3	Base	Per Code	0.36	II		1	5	0.444	0.09	1717.2858	154.5557
13	EQY	Seismic	Y + Ecc. X	5	No	Program Calculated		Story3	Base	Per Code	0.36	II		1	5	0.39	0.09	1717.2858	154.5557
14	EQY	Seismic	X - Ecc. Y	5	No	Program Calculated		Story3	Base	Per Code	0.36	II		1	5	0.444	0.09	1717.2858	154.5557
15	EQY	Seismic	Y - Ecc. X	5	No	Program Calculated		Story3	Base	Per Code	0.36	II		1	5	0.39	0.09	1717.2858	154.5557
16																			

### Modal Participating Mass Ratios;

Case	Mode	Period	UX	UY	UZ	Sum UX	Sum UY	Sum UZ	RX	RY	RZ	Sum RX	Sum RY	Sum RZ
Modal	1	0.444	0.7073	0.0025	0	0.7073	0.0025	0	0.0021	0.1445	0.1627	0.0021	0.1445	0.1627
Modal	2	0.39	0.0028	0.8345	0	0.7101	0.837	0	0.1946	0.0003	0.0002	0.1967	0.1448	0.1629
Modal	3	0.35	0.1506	0.0002	0	0.8607	0.8371	0	0.0253	0.0283	0.7048	0.222	0.1731	0.8677
Modal	4	0.175	0.0864	0.0021	0	0.9471	0.8393	0	0.0112	0.5845	0.0032	0.2331	0.7576	0.8709
Modal	5	0.162	0.0034	0.0955	0	0.9505	0.9347	0	0.5224	0.0233	0.0001	0.7555	0.7809	0.871
Modal	6	0.144	0.0043	0.0081	0	0.9548	0.9429	0	0.0295	0.0282	0.0856	0.785	0.8091	0.9566
Modal	7	0.118	0.0225	0.0085	0	0.9773	0.9514	0	0.0373	0.089	0.0088	0.8223	0.8981	0.9654
Modal	8	0.108	0.0136	0.0294	0	0.9909	0.9808	0	0.1168	0.0587	0.0031	0.9391	0.9567	0.9685
Modal	9	0.093	0.0029	0.0102	0	0.9938	0.991	0	0.0282	0.0163	0.025	0.9673	0.973	0.9934
Modal	10	0.028	0.0001	0.0001	0	0.994	0.9912	0	0.0002	0.0009	0.0001	0.9675	0.9739	0.9936
Modal	11	0.026	0.0001	0.0001	0	0.9941	0.9913	0	0.0004	0.0003	0.0001	0.9679	0.9742	0.9937
Modal	12	0.024	0.0001	0.0002	0	0.9942	0.9915	0	0.0015	0.0003	0.0002	0.9694	0.9745	0.9939

## Base Reaction: Earthquake Reaction

### I) Max Displacement Check;

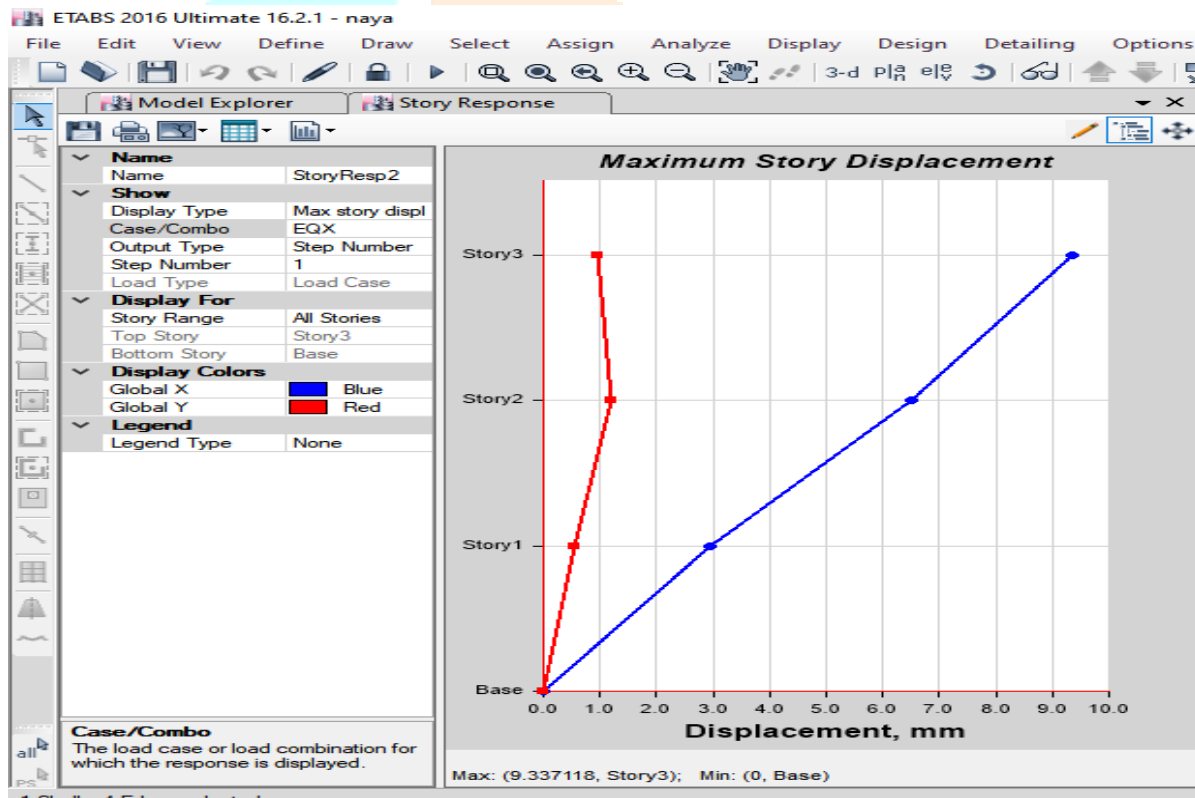

### ii) Max Drift Displacement;

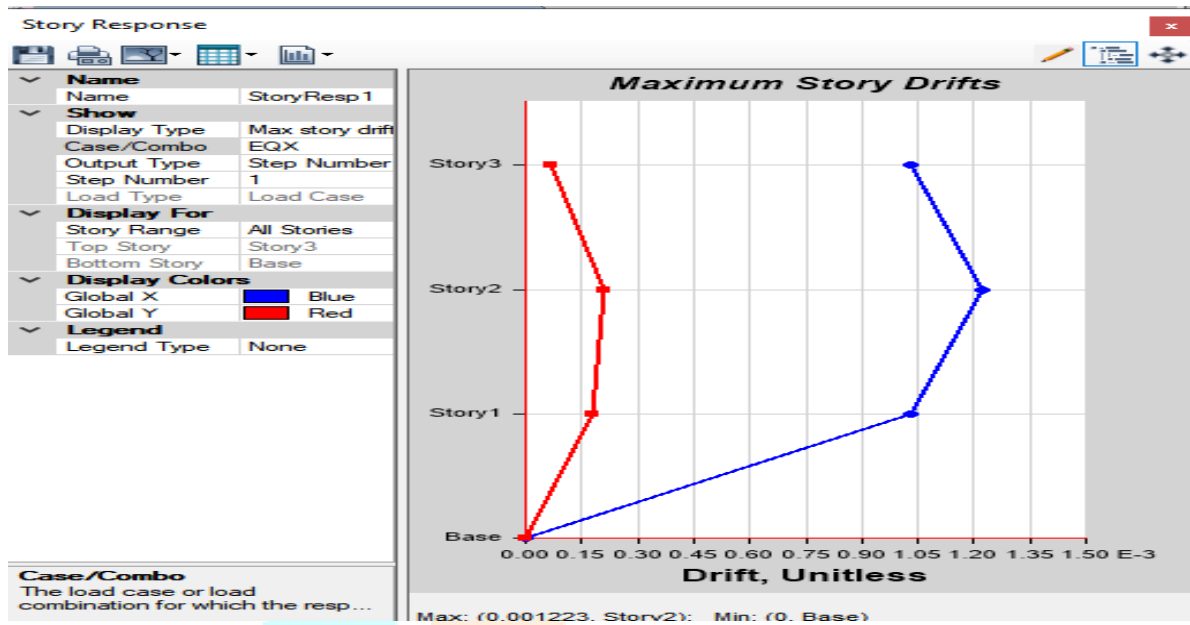

### Reinforcement Design Results;

-D View Longitudinal Reinforcing (IS 456:2000)

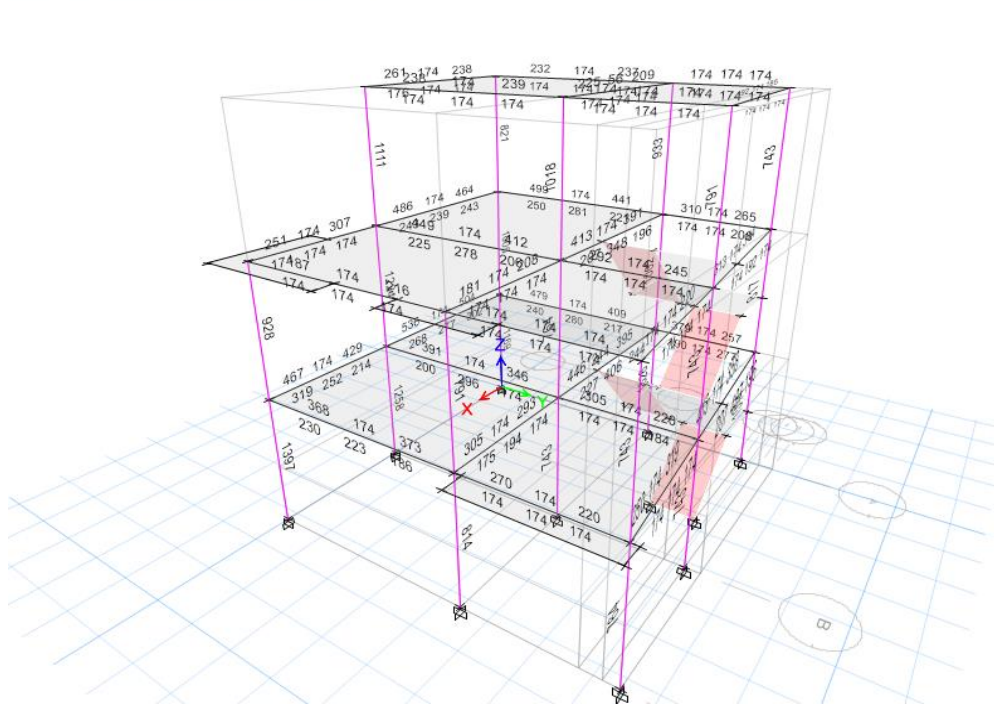



## Staircase Detailing;

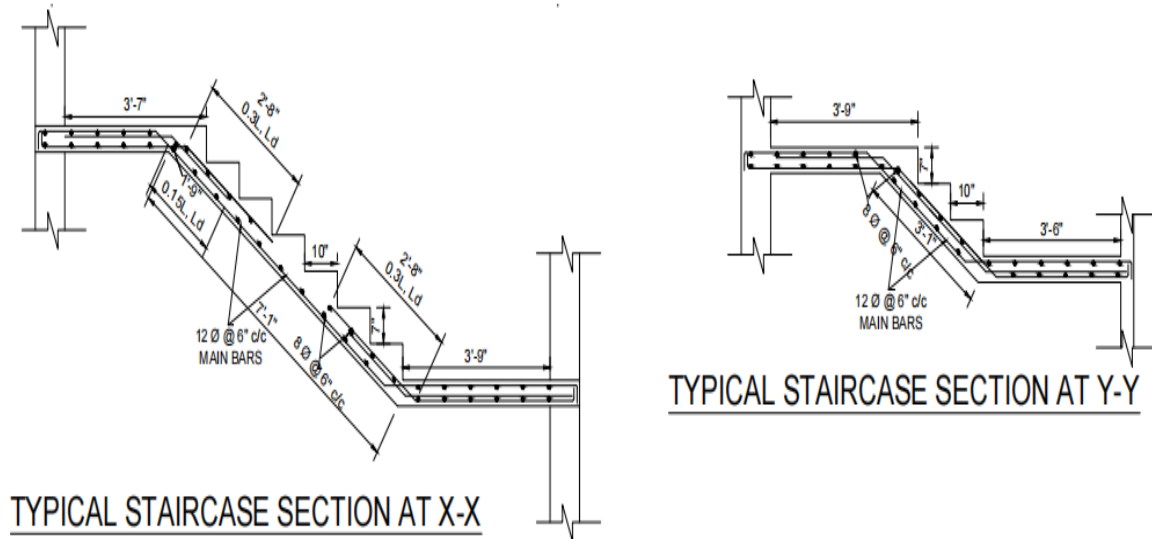

## CONCLUSION

The goal of this was to analyze and design framed structure of the residential building and hence we were able to complete the work with the help of various tools and software which makes our work easier and faster.

## REFERENCES

A.K.Jain, Advanced R.C.C Design.

N.Krishna Raju, Reinforced Concrete Design.

IS 456-2000

Antoniou, S. And Pinho, R. (2006), "Development and verification of a displacement-based adaptive pushover procedure", J. Earthq. Eng., 8(5), 643-661.

ATC-40 (1996), Seismic Evaluation and Retrofit of Concrete Buildings, Applied Technical Council, California Seismic Safety Commission, Report No. SSC 96-01 (two volumes), Redwood City, California, The US.

Bilgin, H. (2013), "Fragility-based assessment of public buildings in Turkey", Eng. Struct., 56, 1283-1294.

Bracci, J.M., Kunnath, S.K. and Reinhorn, A.M. (1997), "Seismic performance, and retrofit evaluation of reinforced concrete structures", ASCE J. Struct. Eng., 123(1), 3-10.

BDCP (1994), Building Code Development Project: Seismic Hazard Mapping and Risk Assessment for Nepal, UNDP/UNCHS (Habitat) Subproject: NEP/88/054/21.03, Min. Housing Phy., Planning, Kathmandu.

Bernal, D. (1987), "Amplification factors for inelastic dynamic P-D effects in earthquake analysis", Earthq. Eng. Struct. Dyn., 15, 635-51.

CBS, Nepal (2012), National Population and Housing Census 2011, National Report, NPHC, Kathmandu.