



## Arduino based Mobile Controlled Smart Shopping Cart for Minimizing Human Efforts

<sup>1</sup>Prof. A. R. Wasnik, <sup>2</sup>Dhawal Jadhav, <sup>3</sup>Sahil Yeginwar, <sup>4</sup>Swastik Borkar, <sup>5</sup>Shrikant Jha

<sup>1</sup>Assistant Professor, <sup>2-5</sup>Student

<sup>1-5</sup>Department of Mechanical Engineering,

<sup>1-5</sup>Sinhgad Institute of Technology, Lonavala, Pune, India

**Abstract:** A shopping cart is a type of transportation or container that can be used by customers to transport their interior design, grocery stores, and grocery stores. A shopping cart is a stroller designed by grocery stores. Our cause of the project is to design an automated shopping cart, to be able to assist buyers, along with a vast ability to avoid obstacles with the help of built-in intelligence. This can be done because the system is controlled by a simple micro-controller (Node-MCU ESP8266), an ultrasonic positioning system, a transmitter, and a receiver-based approach to identifying and locating the victim, and an infrared sensor system for the measurement of the orientation of the obstacle. In the hope of adding intelligence to the values, and the shopping cart is designed in such a way that it could allow for ease of use. The idea is to reduce human efforts and the detection of objects that are virtually devoid of any point of contact, with the aid of sensors. Proximity sensors use high-frequency to detect any obstacles in the vicinity of the sensor. This paper represents the software and hardware design of the automatic transmission trolley.

**Index Terms – Smart Shopping Cart, ESP8266 NodeMCU, Micro-controller, IR Sensors, DC Motors**

### I. INTRODUCTION

Currently, many stores offer comfort one of which is in shopping cart. It is used for in stores customers to transport items at the checkout during a purchase.

Shopping Cart was founded in 1937 as a spin-off of a new way of shopping that was popular in 1920: the grocery store. This was inspired by the idea of American grocery store owner Sylvan Goldman, who came up with a way to encourage customers to buy goods in his Humpty Dumpty through a chain of retail stores. He was getting a lot of complaints from customers because it was difficult for them to carry products from the store. Goldman was trying to solve this problem, and started experimenting with cart in the store. He placed the basket on a horse-drawn carriage with small wheels to carry the groceries. To facilitate and meet with his clients, he asked me to be an engineer to create a modern shopping cart and patent an invention. Since that time, the cart is made of it. To this day, in a modern grocery store, we will find many shopping carts.

After Sylvan Goldman, there are many types of research and discoveries in improving the cart. In 2009, scientists began developing prototypes of computer-generated contextual shopping carts, extracting tablets for traditional models. The goal of the system is to help you shop at grocery stores and attract users' attention. Thus, an interactive doll that helps customers understand and find new products. Early experiments have shown that a prototype can improve and transform the shopping experience. Additional research has started integrating a shopping cart with a mobile robot-this is the concept. The prototype is to integrate a shopping cart with a portable mobile robot with human-like accompaniment.

The reason for this paper is to design an automated shopping cart that it offers good use and efficiency for customers especially the elderly and disabled customers, eliminating human performance to push heavily loaded vehicles. Our goal consists of avoiding collisions with obstacles and finding accessible routes and informing customers while the cart is blocked. To achieve these dreams, we designed the entire module based on our desire for a microcontroller, Arduino, because it has a nice working platform for customers and enough processing speed that satisfies the need for our project. Our project can run automatically under the drive of two 12V DC engines, the power input is controlled by Arduino to adjust the moving speed. The three IR sensors are embedded in the front, left and right of the cart, to determine which route is accessible and to alarm customers when obstacles are detected in their range. Our main microcontroller, Arduino, serves as a data transfer and processing center.

## II. LITERATURE REVIEW

### A. Survey

Several smart shopping carts ideas have arisen so far to bring changes into the design of carts in terms of electronics with innovative ideas for improving shopping experience and reduce human efforts.

### B. Previous Studies

A literature review was conducted for cutting-edge research that started integrating a shopping cart with a mobile robot this is the concept. Various research papers, articles, and information on this paper are studied as part of the research that has been conducted on this topic. The literature indicates that it ranges from 2017 to 2020. Some activities have been carried out by various researchers.

Sr. No	YEAR	TITLE	AUTHOR	FINDINGS
1	2019	DEVELOPMENT OF SMART CART SYSTEM BASED ON ANDROID SMARTPHONE SENSORS	Alexander A S Gunawan, Valdi Stevanus , Albertus Farley , Heri Ngarianto , Widodo Budiharto , Herman Tolle , Muhammad Attamimi	This paper describes the hardware and software design of the smart cart system. They use smart trolleys, IOIO microcontroller, and an Android smartphone from sensors and a controller. The basket is shaped like a two-wheeled mobile robot [1].
2	2020	FEASIBILITY STUDY OF TECHNOLOGY TO IMPROVE SHOPPING EXPERIENCE	Heraldo Y Purwantono, Alexander A S Gunawanb , Herman Tollec , Muhammad Attamimi, Widido Budiharto	This literature review some of the new technologies that are currently under development-a process that was recently introduced based on a feasibility study. The technologies that are being considered, including smart carts, can be, for example, shopping trips and just shopping trips and are supported by relevant research and literature [2].
3	2019	IOT APPLICATION BASED ADVANCED SHOPPING CART	Hiba Sadia, Shubhansu Jee, Krishnendu Pal, Shikhar Singh, Mebansharai Marbaniang	In this paper they suggest the use of RFID installed in a shopping cart to design a clever shopping system. All shopping carts at supermarkets are tagged with RFID tags. Reducing the time spent waiting in long queues during the outgoing process is one of the key objectives in improving customer purchasing experience [3].
4	2017	AN INTELLIGENT SENSING FOLLOWER CART (AUTOMATIC SHOPPING CART)	Sonakshi Rastogi , Vipul Agarwal , Parikshit Singh	This paper discusses the firmware of the automatic transmission design in shopping cart. The results of research on widely used sensors, including ultrasonic sensors and infrared sensors, will be presented [4].

### C. Salient Points Of Literature Survey

1. The literature discusses some of those new technologies that are currently under development process or had been introduced recently based on feasibility analysis.
2. Technologies that are considered including Smart cart, VR Shopping, and Just Walk Out Shopping also supported by related researches and literature.
3. The papers also represent the software program and hardware design of the automatic transferring cart.
4. They propose the use of RFID embedded with the shopping cart to design a smart shopping system.

## III. CONSTRUCTION

### A. Required Software

1. Android Blynk app (Play store)/(IOS)
2. Arduino IDE
3. Blynk library for Arduino IDE

## B. Required Hardware

1. Microcontroller: Microchip ATmega328P
2. Infrared Sensor
3. NODEMCU (WIFI Module)
4. Motor Driver
5. Motor
6. Battery
7. Wires
8. Cart

## C. Configuration Of Blynk App

1. To Start with, Blynk. Please click on the New Project with the name of your project "add to Cart" and choose your device as the "ESP8266" and select "Wi-Fi".
  2. Once you click Create, Blynk will send an e-mail with the project, the authentication token is the code to use.
  3. After you create the project, add a few more buttons, and then click on the "+".
  4. Once you have added the buttons, as shown in the pictures below.
  5. Select a debit card, Virtual>V0 to be the first of a button, and give it the name of "moving Forward".
  6. The second "Back" button, and then select pin to a Virtual>4. Q. You can repeat these steps if you want to add from the left and right controls, but for now, we are testing to move forward and backward.
  7. Get the source code.
  8. We will use the ESP8266 development board is to have the source code to be downloaded.
  9. How to install the ESP8266 bone.
  10. After you have downloaded the source code, the message is to be done.
  11. Install the ESP8266 and the motor driver module with a battery-free and IR-sensors.
  12. We will also make use of a dual-motor, so the bot will not be able to move forward and backward.
  13. Note: Before you start, you will need the SSID and password and the verification code in the program that corresponds to the source code. After the change of the source code, click at Download is.
  14. After installation, open the Blynk app.
  15. Please select the Blynk project, and then click on "Play".
  16. The project is going to start.
- As Blynk is an IoT platform, and the wheelchair can be controlled over the Internet with the help of a mobile app, from anywhere in the world.

## D. Construction (Block Diagram)

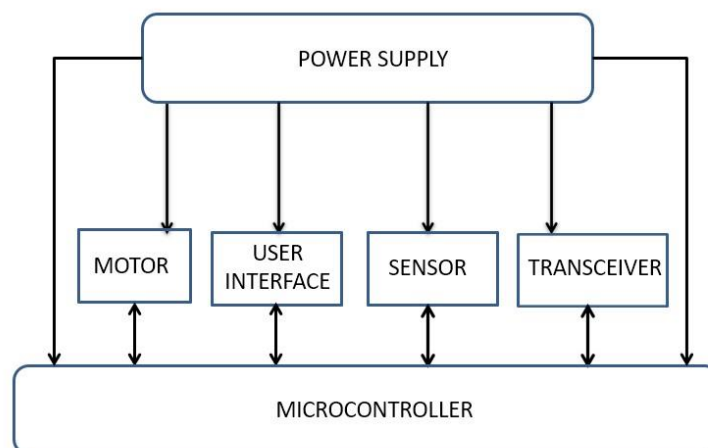

**Fig 1 :** Block Diagram Of Mobile Operated Shopping Cart

## E. Working

At the first stage, when electrical power is applied to the ultrasonic transmitter, it will start transmitting a signal, and the ultrasonic transmitter (receiver) from your cart will start detecting the signal transmitted from the user-tags: ultrasonic transmitter). If the target is within its detection range, the sensor sends a signal to the microcontroller and microcontrollers that will allow it to move as ordered, otherwise the basket will remain active, the basket remains in place. In this way movement of cart will be done.

An infrared (IR) sensor that will identify objects at a distance from the shopping cart, if there is an object that is close to the shopping cart, the sensor will communicate with the microcontroller, the microcontroller will collect and other things with the IR sensor, alarm, - flexible, - and avoid the object.

For example, if:

1. There is an obstacle close to the left side of the shopping cart, the shopping cart will make a right turn to avoid/ keep a distance from the obstacle.

- There is an obstacle close to the right side of the shopping cart, the shopping cart will make a left turn to keep a distance from the obstacle.

#### IV. DESIGN AND APP INTERFACE



Sr. No.	Components
1	Motors and Electronic components
2	IR sensor for accident prevention
3	IR sensor for counting no. of items



Fig 2: 3D Design of Cart and Electronic Components

Fig 3: Customized Blynk App Interface for Controlling Cart

#### V. RESULT

- Cart can easily use to load items in the supermarkets or as per one’s requirement (The DC motors are used to provide automatic motion to the cart. As per requirement DC motors of different specification can be used).
- Cart can be operated with the help of smartphone by connecting with Wi-Fi on mobile and cart.
- Collison prevention is successfully implemented to reduce collisions which occurs due to carelessness of humans. (IR sensors are used to sense the obstacles in the way of the cart).
- User can now enjoy shopping without pushing the shopping carts themselves.

## VI. CONCLUSION

The major goal of this article is to design a shopping cart which is operated with the help of smartphone. The objective of our design is fulfilled as it reduces human efforts which will be more beneficial to the customers who are handicapped or old age peoples. Also, cart will reduce the collisions that occurs due to carelessness of customers during shopping in supermarkets.

## VII. REFERENCES

- [1] Alexander, A. S. G., Valdi, S., Albertus, F., Heri, N., Widodo, B., Herman, T., Muhammad, A. (2019) "Development of Smart cart System Based on Android Smartphone Sensors" Jakarta: 4th International Conference on Computer Science and Computational Intelligence 2019
- [2] "A literature review: Feasibility Study of technology to improve shopping experience" Heraldo YPurwantono<sup>a</sup>Alexander A SGunawan<sup>b</sup>HermanTolle<sup>c</sup>MuhammadAttamimi<sup>d</sup>WidodoBudiharto<sup>e</sup>
- [3] Hiba Sadia, Shubhansu Jee, Krishnendu Pal, Shikhar Singh, Mebansharai Marbaniang "Iot Application Based Advanced Shopping cart" International Journal of Engineering and Advanced Technology (IJEAT) ISSN: 2249 – 8958, Volume-8 Issue-4, April 2019
- [4] Rastogi S., Singh P.K., Agarwal V. "An Intelligent Sensing Follower Cart (AUTOMATIC SHOPPING cart)" Journal of Controller and Converters (2017), pp. 21-25
- [5] Titarmare, S. T. (2017, Februari) "RFID Based Smart Shopping cart with IR Sensor". National Conference on Advances in Engineering and Applied Science. Nagpur, Maharashtra, India (TechnoScience Academy) 139-143
- [6] YL Ng, CS Lim, KA Danapalasingam, MLP Tan, CW Tan Automatic Human Guided Shopping cart with Smart Shopping System Jurnal teknologi., 73 (3) (2015)
- [7] Omar, R., Makadessi, M., Mohamad, Y., Damaj, I. (2018) "SysMART Indoor Services: A System of Smart and Connected Supermarkets" IEEE in 31st Canadian Conference on Electrical and Computer Engineering.
- [8] Farley, A., Stevanus, V. (2018) "Swarm Android Mobile Robot: Smart cart Application" School of Computer Science Universitas Bina Nusantara
- [9] Sainath, S., Surender, K., Arvind, V. V., & Thangakumar, J. (2014). Automated shopping cart for super market billing system. International Journal of Computer Applications, 3, 7-8
- [10] Altarteer, S., Vassilis, C., Harrison, D., and Chan, W. (2016) "Product Customisation: Virtual Reality and New Opportunities for Luxury Brands Online Trading" 21st International Conference on Web3D Technology, Anaheim, California: ACM: 173-174.
- [11] Aishwarya, S. S. (2018, April) "Smart Supermarket Trolley System Using RFID" International Journal of Trend in Research and Development, 529-531.