



DESIGN AND FABRICATION OF RICE TRANSPLANTATION MACHINE

Prof. GOVIND JAGTAP, TEJAS BHADE, PRADEEP GADE, WILFRED GONSALVES, GUFRAN KHAN

Bharati Vidyapeeth's College of Engineering, Navi Mumbai, Maharashtra, India

Abstract --A rice transplanter is a specialized machine used to transplant rice seedlings in the field. A common rice transplanter comprises: •seedling tray like a shed roof on which mat type rice nursery is set. •A seedling tray shifter that shifts the seedling tray like the carriage of typewriters, • Plural pickup forks that pick seedlings up from mat type nursery on the seedling. Tray and put the seedlings into the earth, as if the seedling were taken between. Human fingers. Machine transplanting using rice transplanter requires considerably less time and labour than manual transplanting. Hence need of rice transplanter machine is growing nowadays because it unique features seeding in well sequence and in well manner Seeding by rice transplanter saves too much efforts of human being. Class of people who uses this kind of machines is farmers and they are having poor economic background. Rice planting is very old method from many years ago & having long history since many years & their methods of rice planting are changed in this decade. Use of rice Transplanter machines is new trend but current machines having high cost of purchase. So, the focus of this project is to minimise the cost of that machine and therefore to design a machine using simple arm mechanism, four bar mechanism with simple gear transmission which helps in reduction in maintenance cost.

I. INTRODUCTION

India is a country of villages, having large population around two third of its population are dependent on agriculture. The sole culprit for slogging in pace of accretion in ago industry is dependency on traditional approaches and equipment for enhancing the per capital agricultural production, various innovative efforts are made at national level under the name Agricultural Revolution. Revolution is confined to economic growth which may result from various economic factor, but technological progress has been and will continue to be the primary source of development. Technology refers to the application of scientific approach for practical purpose as well as industrial purpose for enacting and enriching goods

and services. For the production of rice, which is gradually a major production crop in Konkan the rice should be dropped at a regular interval. But the existing equipment does not fulfil these criteria in India. In existing system, plant is dropped manually at the cross point of longitudinal and lateral cultivation which increase the cultivation time as well as labor cost. But by this device both the operation i.e., cultivation and rice planting can be done simultaneously. In this system there is no need to drops the rice plant more than one times and no wastage of costly rice plants. And we save the production cost as well as cultivation time and labor cost And, get more yields. In existing system there was a possibility to germination of more than one plant at a single position, and transplantation of that extra plant was. Necessary. But in this system of drilling, this type of problem considered as negligible. In future, this device will help the rice planter farmers to change their lifestyle. The rice transplanter consists of prime mover, transmission mechanism. lugged wheels, rice ling tray, rice ling tray shifter, pickup fork pickup fork cleaner. It transplants the rice ling uniformly without damaging them.

II. LITERATURE REVIEW

Baldev Raj, Kamboj Dharam [1] studied production of rice and onion and design a machine which consists of prime mover, transmission, engine, float, lugged wheels, rice ling tray, rice ling tray shifter, pickup fork and pickup fork cleaner. It is a walk behind type rice transplanted using mat type nursery.

Mahesh Kumar [2] had done total CAD design with overall dimensions in which transplanting of paddy seedlings can be categorized into three groups as follows: By band manual, manually operated machines i.e. work by man power and third is mechanically operated machines work by engine power.

Robert fisher [3] told about basic types of rice planter machine i.e., riding type and walking type. Riding type is power driven and can usually transplant six lines in one pass. On the other hand, walking type is manually driven and can usually transplant four lines in one pass.

Overall, Transplanting of Paddy Seedlings can be categorised into 3 major groups:

1. By Hand (manual), which does not require costly machines and is most suited for labor-surplus areas and for small rice fields.
2. Manually operated machines (work by manpower), which are powered by manpower Operator has move with the transplanter and power the machine by hand. These machines are small enough to operate manually.
3. Mechanically operated machines (work by engine power), which are powered by engine, Operator has to move with the transplanter or in some; the operator can sit on it. There are two type of engine operated transplanter-
 - A. Walking behind rice transplanter ,
 - B. Self-propelled rice transplanter (Riding type)

Conclusion drawn from literature survey:

From above literature survey we have found that the existing Manually Operated Plantation machines are capable of planting four or six lines in one pass and hence these machines are suitable for large lands. But these machines are not that much suitable for small lands and also not affordable for farmers who are having small lands.

III. OBJECTIVE

1. To design rice transplanter is to develop the simple system.
2. Easy in handling and lower in cost.
3. The engine based Rice transplanter machine can also be used,

But to make easy working and lower cost we have designed the manual rice transplanter. Mechanical transplanting of rice is the process of transplanting young rice seedlings, which have been grown in a mat nursery, using a self-propelled rice transplanter. In conventional manual transplanting practice, 8-12 labors are required to transplant one acre. However, if a self-propelled rice transplanter is used, three people can transplant up to four acres in a day. Proposed CAD model of rice transplanter shown in fig.1.

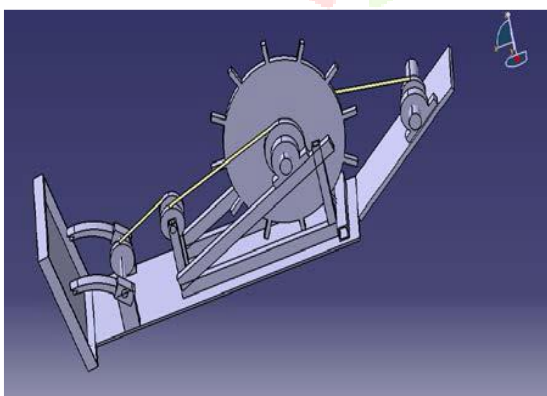

Fig.1 Proposed CAD model of rice transplanter

IV. LIMITATIONS OF OLD METHOD

Transplanting is tedious and time-consuming (up to 30 man days/ha)

1. Planting labour can suffer from back problems (health risk).
2. Difficult to get enough labour at peak periods to plant on time.
3. Difficult to maintain optimum spacing and uniform plant density, especially with random transplanting and contract labour.
4. Low plant density with contract transplanting on area basis lowers yields.
5. Possible Risk that in rain fed areas seedlings (especially of modern varieties) may get too old before rain falls and the field is ready to be planted.
6. Due to the expensive costs of manually operated transplanter available in the market, Small scale farmers are not able to afford it.
7. Total Manufacturing cost is around 4000₹, which is comparatively cheaper to the machines available in the market.

V. ADVANTAGES OF RICE TRANSPLANTER

Efficient use of resources by saving on labour, cost saving, water saving.

1. Timely transplanting of seedlings of optimal age.
2. Ensures uniform spacing and optimum plant density with 2-3 seedlings/hills).
3. Higher productivity compared to traditional methods.
4. Less transplanting shock, early vigour of seedling, uniform maturity of crop that facilitates timely harvest and reduces harvest losses
5. Generates employment and alternate sources of income for rural youth through custom services on nursery raising and mechanical transplanting.
6. Better employment opportunities for rural youth through the development of custom service business.
7. Addresses the problem of labour scarcity.
8. Increases farmers' net income.

VI. CONCLUSION

Newly developed system is also effective as compared Systems available in the market. New trans-planter having simple construction and a smaller number of parts which minimizes the cost of development for it. Two bar mechanism is used to carry out the motion of the arms. Total cost required to develop the system is also less. New rice trans-planter machine is more flexible than machines available in the market at starting cost. In future we are also planning to increase the transplanting rows from 2 to 4 or 6 rows. Motor or diesel engine can be used for automation of machine. And as the working of electrical machine in Automation field will try to make a prototype as well.

VII. REFERENCES

- 1) Baldev Raj Kamboj Dharam Bir Yadav, Mechanized Transplanting of Rice in Nonpadded and No-Till Conditions, American Journal of Plant Sciences, 2013, 4, pp. 24092413
- 2) Mahesh Kumar, Design Process Rice Transplanting Machine, Manufacturing process journal, IIT Kanpur, pp. 1-22
- 3) Robert Fisher, Basic types of Rice Planter Machine
- 4) Bir Yadav, Mechanized Transplanting of Rice (Oryza Sativa L.) in Nonpadded and
- 5) No-Till Conditions in the Rice-Wheat Cropping System in Haryana, India, American
- 6) Journal of Plant Sciences, Vol 4 No 12, 2013, pp. 24092413
- 7) Reference book of Design of Machine Elements -V.B. BHANDARI
- 8) Reference book of Design of machine -R.S. KHURMI
- 9) <http://www.livescience.com>
- 10) <http://www.howstuffworks.com/>
- 11) <https://www.Voutube.com/2gl=-IN&tab wl>
- 12) <http://en.wikipedia.org>
- 13) <http://www.sciencemag.org/>

