



# PID- FUZZY LOGIC CONTROL OF FORWARD BUCK CONVERTER FOR MODERN AIRCRAFT APPLICATION

<sup>1</sup>L Sakthivel, <sup>2</sup>Dr.S. SenthilKumar,

<sup>1</sup>PG Scholar, <sup>2</sup>Professor,

<sup>1</sup>Department of Electrical and Electronics Engineering,

<sup>1</sup>Government College of Engineering, Salem, Tamil Nadu, India

**Abstract:** This paper with the design model and analysis of modern aircraft electrical power system (AEPS) using fuzzy logic control (FLC) technique with implemented proportional integral derivative (PID) control. In order to meet the standards of the of the aircraft, the behaviours of the aircraft electrical power system (AEPS) during load switching is controlled using PID -FLC technique. This technique is mainly suitable for the control of generator control unit, Ac-Dc controlled rectifier. In this proposed paper, the simulation of power MOSFET based Dc-Dc converter forward buck converter has been done in the MATLAB/SIMULINK and their corresponding voltage and current waveform are plotted obtained. To achieve high power factor and to have high efficiency, the advantage of forward buck converter is contained to form a novel forward buck converter. It is capable of operating in forward buck converter. Hence the lesser are highly reduced and the current near the zero crossing of input side is reduced using the balancing capacitor. The variable reactive load is employed to demonstrate the value of harmonic reduced at various value of voltage and current in the system.

**Index Terms - Fuzzy Logic control, Proportional integral derivative control, rectifier.**

## I. INTRODUCTION

A combination of hydraulic, electrical, pneumatic and mechanical power transfer systems is highly utilized by the conventional aircraft power systems [1]. For advanced aircraft power systems, the increased use of electrical power has paved the way to rapidly evolving technology advancements in power electronics, fault-tolerant electrical power distribution systems and electrical driven primary flight control actuator systems. In the More Electrical Aircraft (MEA), the electric power is used to drive the aircraft subsystems, whereas in conventional aircraft it is driven by a combination of mechanical, hydraulic and pneumatic systems [2]. The MEA completely or partially replaces the nonelectrical system of aircraft into the electrical system. Initially it was applied to meet the military grade for reducing the overall weight of the aircraft, maintenance costs and to improve the higher reliability for better performance with increased capacity and standards of the civil aircraft. In recent years, power quality and the need for required powers have been the most important research topics because of the use of non-linear electronic components such as, switched mode power supply, incandescent bulb lighting and motor drive applications etc [3]. The non-linear loads are capable of creating harmonic current and reactive power problems. These harmonics will induce non linearity and distortions in sensitive equipment like overvoltage by resonance, increased heating in the conductors, harmonic voltage drop across the network impedance and affect the various loads at the common point of coupling. Conventionally passive LC filters are utilized to compensate the harmonic distortion and the reactive power; but the passive filters have the following drawbacks. It includes large size, aging and tuning problems, resonate with the supply impedance and fixed harmonic compensation [4]. The MEA concept is seen as the future of aircraft power system technology. The multi-voltage level hybrid DC and AC systems are employed by the aircraft power system. Thus, MEA electrical power system offers multi-converter for the power conversion. The modern electrical aircraft uses an input voltage of 400V AC and is connected between the forward converter whose output voltage is 28V DC and the input voltage is 270V DC [5]. The MEA is intended to have limitless advantages. It includes optimizing the aircraft performance and decreasing the operation and maintenance costs. Moreover, MEA has reduced emissions of air pollutants from aircraft which mitigates the global warming and its associated climatic changes. The MEA challenges the conventional aircraft electrical system in terms of the custom power, the processing and utilization of this power. In this paper, modeling, performance analysis and control of an MEA electrical power distribution system is investigated. The MEA aircraft has multiple DC and AC buses at variable frequencies to power the variable load types within the aircraft [6]. Fuzzy logic-based control of forward buck converter is discussed. Fuzzy logic control (FLC) gives outstanding advantages over the conventional controllers (PID) such as ease [7] in the development, provides a wider range of operating conditions, and more readily customizable language terms. The obtained results shows that the FLC is superior compared to the conventional control for the desired modern aircraft electrical power system.

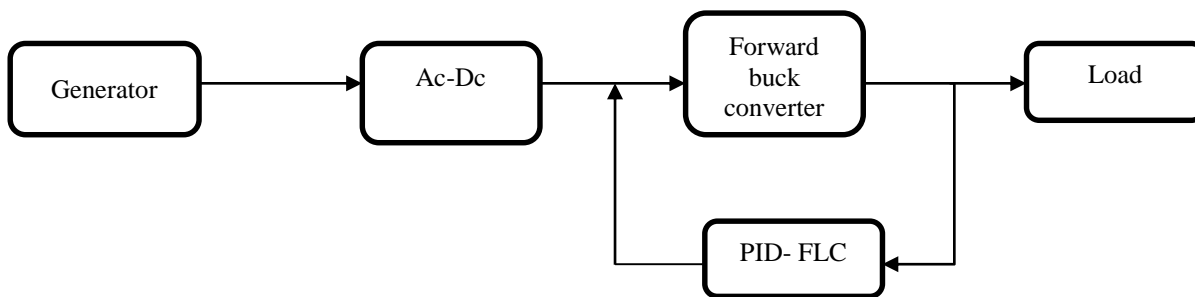

Fig.1. Block diagram of modern aircraft electrical power system

## II. MODERN AIRCRAFT ELECTRICAL POWER

The modern aircraft's electrical generation and conversion efficiencies are slightly more than that of the existing aircraft electrical system. The pilot's cabin communication and electronic devices are fed by 28V DC bus system and they are connected with batteries to operate under emergency conditions. In order to get 28V DC from 400V AC a three-phase bridge rectifier with forward buck converter is provided. The PID-FLC based control is used for controlling the forward buck converter. The voltage at 28V DC are simulated and the results are obtained.

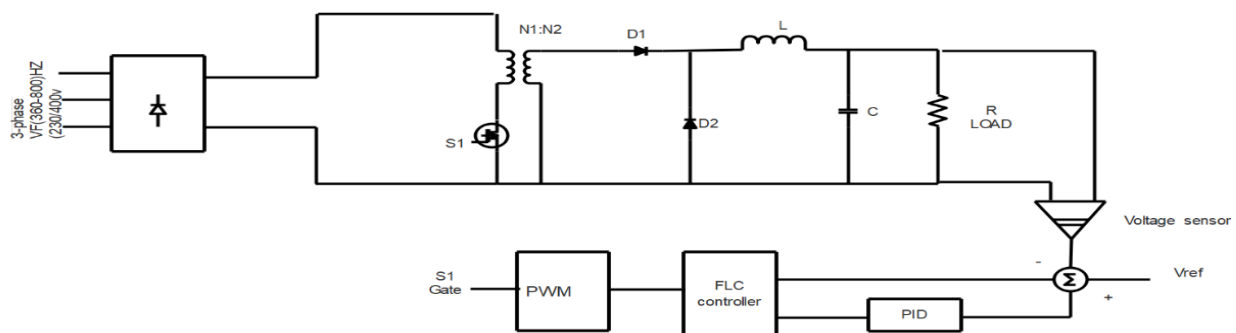

Fig.2. The proposed forward buck converter Topology with PID-FLC

### 2.1 MAE Generator Operation

The modern aircraft is provided with two three-phase synchronous generators, placed on each side of the aircraft. Every synchronous generator provides a total output power of 250 KVA with a Line - Line output voltage of 400 V<sub>LL</sub> and the range of frequency is from 360 Hz to 800 Hz. Apart from generators, there exists two auxiliary power units (APUs), with their ratings similar to the main generators except that their output power from each unit is 225 VA. These APUs will operate only under emergency conditions such as during the failure of the main generators. The PID based Fuzzy logic control is given to provide suitable excitation voltage for the GCU to maintain the output voltage of the generator within the aircraft standards whenever the engine speed or electrical load changes.

### 2.2 AC to DC Converter

The AC to DC converter is capable of converting the value of AC Voltage from one magnitude to the value of DC voltage at the required magnitude. These AC to DC conversion is required to operate the various appliances according to our needs and at various magnitudes. The uncontrolled diode rectifiers are used for providing the AC to DC conversion. It consists of a diode bridge which is capable of providing the required DC voltage at the output through the AC to DC conversion.

### 2.3 Forward Buck Converter

The Forward converter is one of the most important and popular switched mode power supply (SMPS) circuit capable of developing isolated and controlled dc voltage from an unregulated dc input. As in fly-back converter, the dc voltage at the input is derived after rectification with little filtering of the utility ac grid voltage. When compared to the fly-back circuit, the forward converter has more efficiency in terms of energy and is used for applications requiring high power output. However, in terms of the circuit topology, especially the filter at the output is not as simple as in the case of fly-back converter. This forward converter has a fast-switching device 'S' with its own control circuit, a transformer with its primary side connected in series with switch 'S' to the input side and a rectification and filtering circuit is connected to the secondary winding of the transformer. Across the rectified output of the transformer-secondary winding the load is connected. An ideal transformer with no leakage fluxes, zero magnetizing current and no losses has been used as a transformer at the forward converter. The operation of the circuit is explained by assuming an ideal circuit element and the non-ideal characteristics of the devices are brought into consideration by doing a modification in the circuit design. Since there is a presence of finite magnetizing current in a practical transformer, a tertiary winding needs to be introduced in the transformer and the circuit topology is changed slightly. For better reasoning of the steady-state behavior of the converter, the operation of the circuit is divided into two different modes, mode-1 and mode-2. Mode-1 corresponds to the switch is 'on' duration of the switch and mode-2 corresponds to its switch is 'off' duration circuit, the forward converter has more efficiency in terms of energy and is used for applications requiring high power output. However, in terms of the circuit topology, especially the filter at the output is not as simple as in the case of fly-back converter. This forward converter has a fast-switching device 'S' with its own control circuit, a transformer with its primary side connected in series with switch 'S' to the input side and a rectification and filtering circuit is connected to the secondary winding of the transformer. Across the rectified output of the transformer-secondary winding the load is connected. An ideal transformer with no leakage fluxes, zero magnetizing current and no losses has been used as a transformer at the forward converter. The operation of the circuit is explained by assuming an ideal circuit element and the non-ideal characteristics of the devices are brought into consideration by doing a modification in the circuit design. Since there is a presence of finite magnetizing

current in a practical transformer, a tertiary winding needs to be introduced in the transformer and the circuit topology is changed slightly. For better reasoning of the steady-state behavior of the converter, the operation of the circuit is divided into two different modes, mode-1 and mode-2. Mode-1 corresponds to the switch is 'on' duration of the switch and mode-2 corresponds to its switch is 'off' duration.

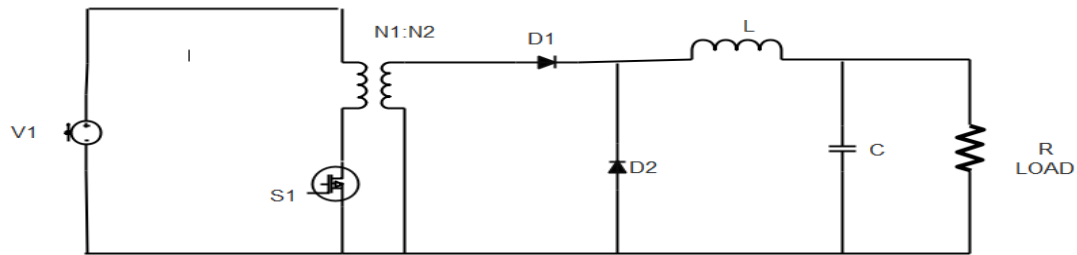

Fig:3. Equivalent circuit diagram of forward buck converter

### Mode Operation 1:

Mode-1 starts after the switch 'S' is turned ON. During this operation, the input voltage  $E_{dc}$  is connected to the primary winding. By turning on the switch, both the primary and secondary windings start conducting simultaneously. Like in an ideal transformer, the primary and secondary winding currents and voltages are related to their turns-ratio ( $N_P / N_S$ ), the current carrying path of the circuit and the functional circuit model is depicted in bold lines. When the switch 'S' closes, diode D1 at the secondary circuit is forward biased whereas the input voltage is scaled by the transformer turns ratio, which is applied to the secondary circuit. The Diode D2 will not conduct during mode-1, as it will remain in reverse biased condition. It is seen that the output circuit with L-C filter and the load gets a voltage equal to DC voltage.

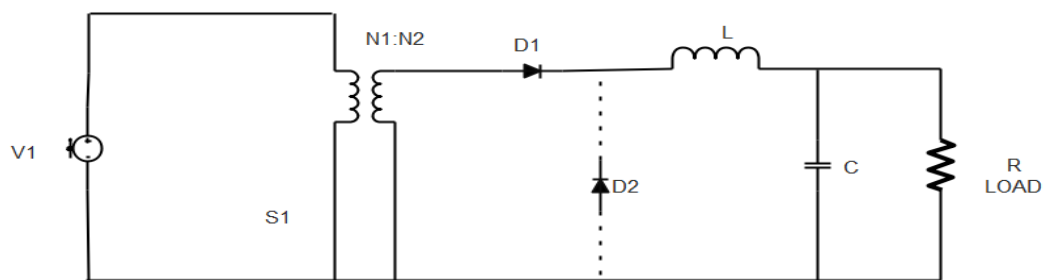

Fig:4. Equivalent circuit diagram of forward buck converter of mode 1 operation.

### Mode Operation 2:

As soon as when the switch 'S' is turned off, the primary and the secondary winding currents in the transformer falls to zero. However, the filter inductor placed at the secondary side of the transformer maintains a continuous current through the freewheeling diode 'D2'. At this stage, the Diode 'D1' remains in off state and the output circuit is isolated from the transformer and the input side. In this circuit, the current carrying section is displayed in bold line and the equivalent circuit is active during the mode-2 of operation. The Points 'P' and 'N' in the equivalent circuit are effectively shorted due to the conduction of diode 'D2'. This inductor current flows through the parallel combination of the load and the output capacitor. During this mode-2 of operation, no power flows from source to load but the load voltage is constantly maintained by the large output capacitor 'C'. The charged capacitor and the inductor tend to provide continuity in the output load voltage. Since there is no input power during the mode-2 of operation, the energy stored in the filter inductor and capacitor is slowly dissipating through the load and during this mode the magnitudes of the inductor current and the capacitor voltage starts decreasing slightly. In order to limit the magnitude of the load voltage within the required tolerance band, the converter-switch 'S' is turned on again to end the freewheeling mode for the start of next powering mode(mode-1). Under this steady state condition, in mode - 2 it is found that there is no loss in the inductor current and capacitor voltage and those values are exactly the same as in mode-1. It is hard to find that in order to limit the magnitude of the load voltage within the desired tolerance level, the value of the filter inductor and capacitor magnitudes should be significantly large. In order to maintain the cost and physical size of the filter within the lower values, the size of these elements should not be made too large. For developing more fast dynamic control over the output voltage, the size and cost of the filter elements should not be made too large.

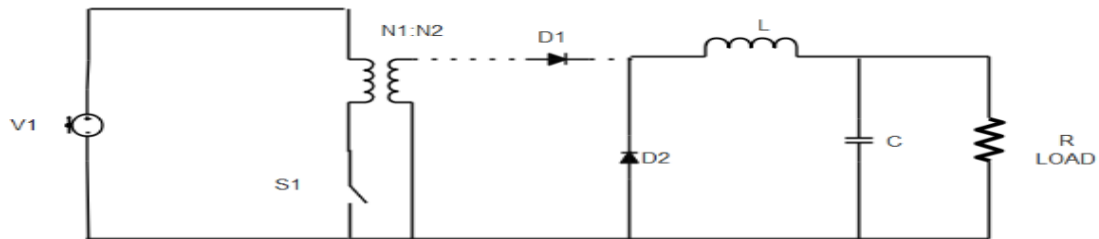

Fig:5. Equivalent circuit diagram of forward buck converter of mode 2 operation.

### III. THE DESIGN OF THE PID- FUZZY LOGIC CONTROLLER

#### 3.1 Fuzzy Logic Controller

For providing the improved system performance and to after better solution for the non-linear control process, a technique called fuzzy logic control is adapter. It is based on the human capability to recognize the behavior of the system by using qualitative control rules. In order to model inaccurate model, the FLC technique is prescribed over other conventional logic. It after a simples and more reliable and control action. this fuzzy logic controller contains three components. They are

- Fuzzification
- Rule base
- De-fuzzification

During fuzzification the input value form the real world are modified in to linguistic variable to permit the input physical signal to approach the rule base through the designed membership function

In the rule base, the fuzzy input from the controller is compared. De-fuzzification again converter the output to the crisp ones and it select different control output based on the rule base.

#### Fuzzification

Since the fuzzification use linguistic variable, in a system where effective control is require the value of error between the reference and the output signal can be denoted as Negative big (NB), Negative Medium (NM), Negative Small (NS), Zero (ZE), Positive Small (PS), Positive medium (PM), positive Big (PB). The membership function used for fuzzification is of the triangular membership function from. Thus, in fuzzification the numerical variable real number gets converter to a linguistic variable fuzzy number.

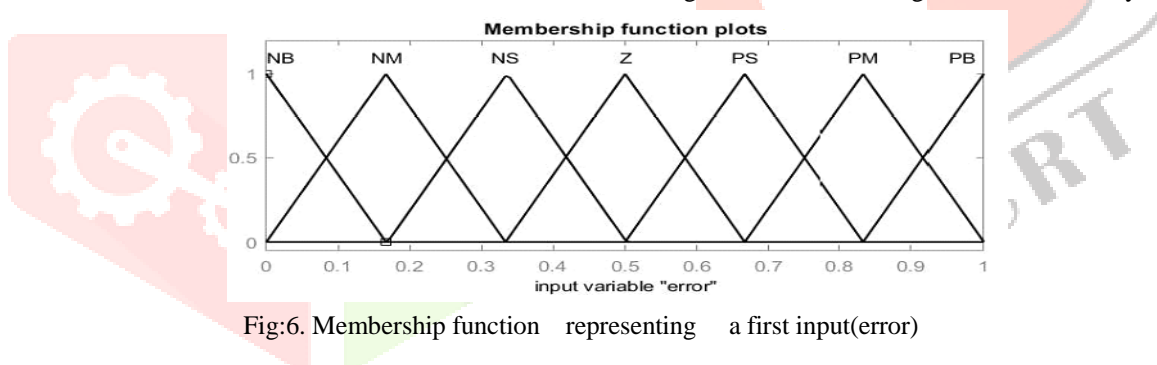

Fig:6. Membership function representing a first input(error)

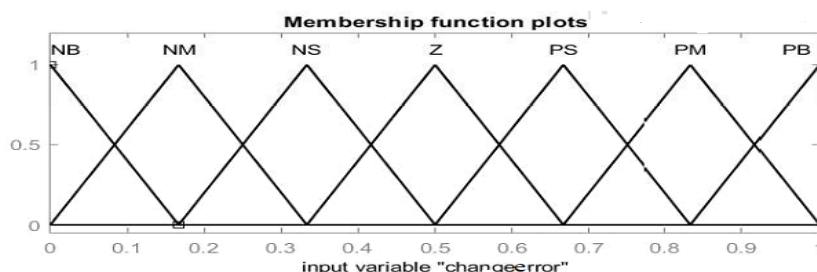

Fig:7. Membership function representing a second input (change in error)

#### Rule Evaluator

Apart from the convention converter like PI and PID whose control is mainly based the gains, which are numerical values. The degree of membership function represents the value of the linguistic variable like error (signal) change of error and output. The basic set operation uses rules like AND, OR, NOT for evaluating the fuzzy operation. The rule evaluator decision making logic require the linguistic control rules stored in the rule base. These rules are mainly based on the PID-FLC scheme and it works mainly for the generator control unit and frequency control.

The rules of fuzzy logic controller are;

1. If error is NB and  $ce$  is NB the output is 0;
2. If error is NM and  $ce$  is NB the output is 5;
3. If error is NS and  $ce$  is NB the output is 50;
4. If error is ZE and  $ce$  is NB the output is 100;
5. If error is PS and  $ce$  is NB the output is 100;
6. If error is PM and  $ce$  is NB the output is 100;
7. If error is PB and  $ce$  is NB the output is 100;
8. If error is NB and  $ce$  is NM the output is -5;
9. If error is NM and  $ce$  is NM the output is 0;
10. If error is NS and  $ce$  is NM the output is 5;
11. If error is ZE and  $ce$  is NM the output is 50;
12. If error is PS and  $ce$  is NM the output is 100;
13. If error is PM and  $ce$  is NM the output is 100;
14. If error is PB and  $ce$  is NM the output is 100;
15. If error is NB and  $ce$  is NS the output is -50;
16. If error is NM and  $ce$  is NS the output is -5;
17. If error is NS and  $ce$  is NS the output is 0;
18. If error is ZE and  $ce$  is NS the output is 5;
19. If error is PS and  $ce$  is NS the output is 50;
20. If error is PM and  $ce$  is NS the output is 100;
21. If error is PB and  $ce$  is NS the output is 100;
22. If error is NB and  $ce$  is NS the output is -100 ;
23. If error is NM and  $ce$  is NS the output is -50;
24. If error is NS and  $ce$  is NS the output is -5;
25. If error is ZE and  $ce$  is NS the output is 0;
26. If error is PS and  $ce$  is NS the output is 5;
27. If error is PM and  $ce$  is NS the output is 50;
28. If error is PB and  $ce$  is NS the output is 100;
29. If error is NB and  $ce$  is NS the output is -100;
30. If error is NM and  $ce$  is NS the output is -100;
31. If error is NS and  $ce$  is NS the output is -50;
32. If error is ZE and  $ce$  is NS the output is -5;
33. If error is PS and  $ce$  is NS the output is 0;
34. If error is PM and  $ce$  is NS the output is 5;
35. If error is PB and  $ce$  is NS the output is 50;
36. If error is NB and  $ce$  is NS the output is -100;
37. If error is NM and  $ce$  is NS the output is -100;
38. If error is NS and  $ce$  is NS the output is -100;
39. If error is ZE and  $ce$  is NS the output is -100;
40. If error is PS and  $ce$  is NS the output is -50;
41. If error is PM and  $ce$  is NS the output is -5;
42. If error is PB and  $ce$  is NS the output is 0;
43. If error is NB and  $ce$  is NS the output is 5;
44. If error is NM and  $ce$  is NS the output is -100;
45. If error is NS and  $ce$  is NS the output is -100;
46. If error is ZE and  $ce$  is NS the output is -100;
47. If error is PS and  $ce$  is NS the output is -50;
48. If error is PM and  $ce$  is NS the output is -5;
49. If error is PB and  $ce$  is NS the output is 0;

### De-Fuzzification

According to the real world dement the fuzzy logic rules generate demanded output in the form of linguistic variable. The linguistic variable is transferred to the real number called crisp output. These are numerous option available for defuzzification. In the defuzzification, three important and different steps are used, they are center of area or centroid.

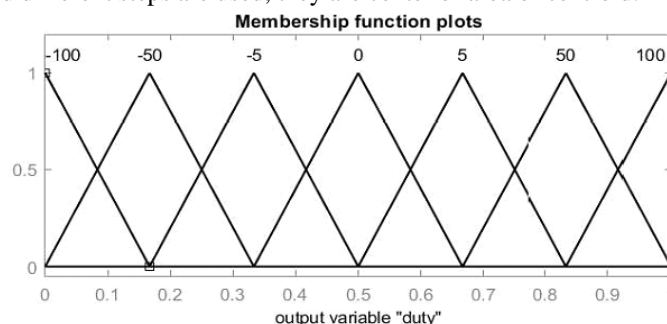

Fig:8. Membership function representing the output (duty cycle)

### 3.2 PID Controller Design

Tuning of PI controller by ziegler Nicholas method is one of the oldest methods of tuning of PID controller. Remove integral and derivative action. Set integral time it largest value sand set the derivative controller to zero. Create a small disturbance in the loop by changing the set point. Adjust the proportion. Increasing and or decreasing the gain unit. The oscillation have constant amplitude. Record the gain value (Ku) and period of oscillation (Pu).

Table: I. PID controller design

	Ke	Ti	Td
P	0.5Ku		
PI	0.45Ku	0.45Ku/Tu	
PID	0.6Ku	1.2Ku/Tu	0.6KuTu/8

$$G(s)=1/s(s + 1)(s + 3) , \quad (1)$$

$$G(s)=1/(S^3 + 4S^2 + 3S),$$

To find transfer function

$$T.F=KG(s)/(1 + KG(S)H(S) ),$$

$$T.F = Kp/(S^3 + 4S^2 + 3S + Kp), \quad (2)$$

Using Routh, find critical

$$Kp/(S^3 + (4S^2 + 3S + Kp)) = (12 - Kp)/4 > 0 \quad (3)$$

$$Kp = Kcr=12,$$

Using even equation substitute with critical using complex. Domain to find critical

$$4S^2 + Kp = 0 \quad (4)$$

$$\text{Where, } S = j\omega$$

$$\omega = 2\pi f = \sqrt{3} \quad (5)$$

$$2\pi/Tu = \sqrt{3} \quad (6)$$

$$Tu = 3.6276$$

Find Ki,Kd,Kp from the Table I

$$Tu = 3.6276 \quad (7)$$

$$Kcr = 12 \quad (8)$$

$$Kp = 0.6*12 \quad (9)$$

$$Ki = 1.2*12/3.627 \quad (10)$$

$$Kd = 0.6/8*12*3.6276 \quad (11)$$

### IV. DESIGN OF FORWARD BUCK CONVERTER

The forward buck converter design of duty cycle

$$N1/N2 = Vs/Vo D \quad (12)$$

Design of inductor value

$$L = \frac{Vo(1-D)}{\Delta Ii f} \quad (13)$$

Design of capacitor value

$$Co = \frac{VoD}{fsR\Delta v_0} \quad (14)$$

Where,

$f_s$  = switching frequency

$\Delta I_i$  = peak to peak ripple current

$\Delta v_0$  = ripple voltage

$N1/N2$  = Transformer turn ratio

Ac side input power

$$\text{Input power } P_{in} = \sqrt{P^2 + Q^2} \quad (14)$$

Where,

$P$  = Active power

$Q$  = reactive power

Dc side output power

$$\text{Output power } P_o = \frac{V_o^2}{R_L} \quad (15)$$

Where,

$V_o$  = output voltage

$R_L$  = load resistor

$$\text{To find efficiency} = (\text{output power} / \text{input power}) * 100 \quad (16)$$

## V.SIMULATION RESULTS AND DISCUSSIONS

The simulation part of the proposed converter idea involves the use of a three-phase bridge rectifier at the 400v Ac voltage at the input side to the required 270v Dc at the output side of the rectifier circuit. After reduction, this Dc voltage is fed as an input to the proposed forward buck converter which again limits or convert the voltage to 28v Dc which is used for various operations carried out within the aircraft power system. The control to the forward buck converter is done using the PID-FLC control technique, which provides required control signal for the effective buck operation waveform.

Table: I simulation of parameter

S.NO	COMPONENTS	PARAMETERS
1	Rectifier input voltage	400V AC
2	Rectifier output voltage	270V DC
3	Forward buck converter Output voltage	28 V DC
4	Switch	Mosfet
5	Resistor	5 Ohm
6	Inductor	200 $\mu$ H
7	Capacitor	400 $\mu$ H

### 5.1 Open Loop Forward Buck Converter

In this open loop forward buck converter, the duty cycle is provided manually to the switch by human intervention. The feedback loop is not provided in the open loop procedure. Here, the control of output is not possible.

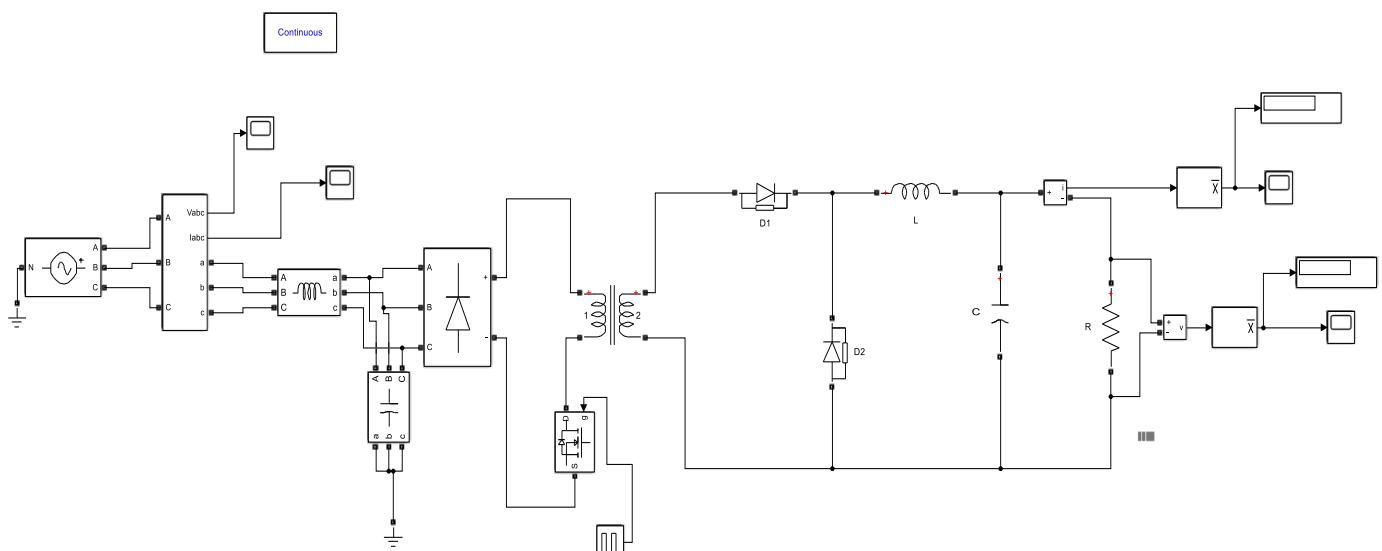

Fig.9. Simulation model of open loop forward buck converter.

### Output Current

The fig.10. describes the simulation results of the output current.

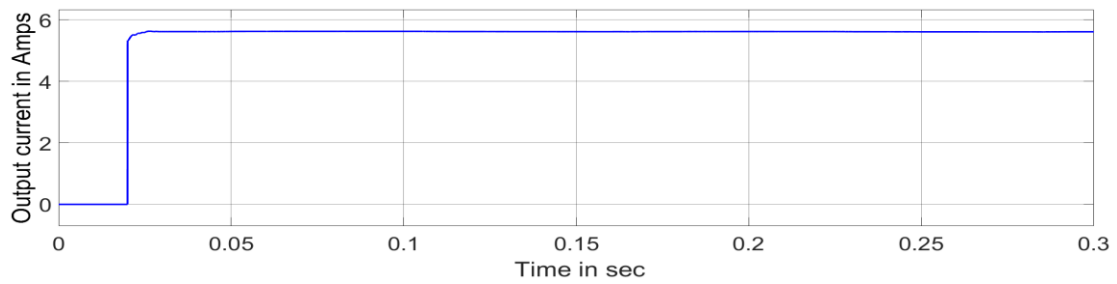

Fig:10. Simulation result of output current

### Output Voltage

The simulation result of the output voltage is shown in fig. 11.

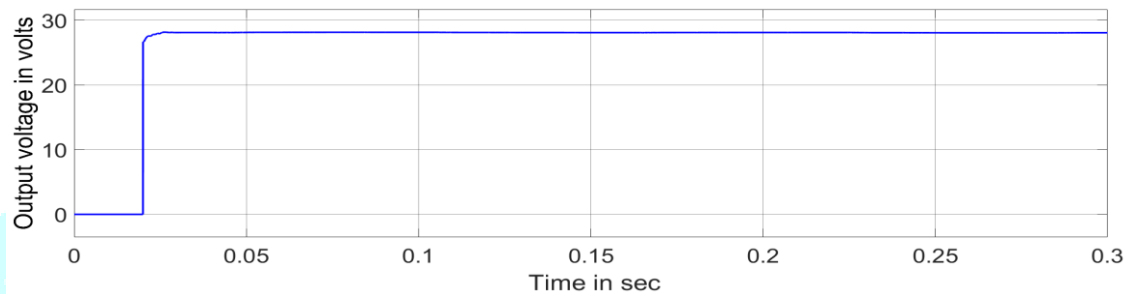

Fig:11. simulation result of output voltage

### 5.2 Closed Loop Forward Buck Converter

In order to achieve accurate output value, the feedback from the output is provided to the controller to correct the output to get the desired and accurate value of output voltage.

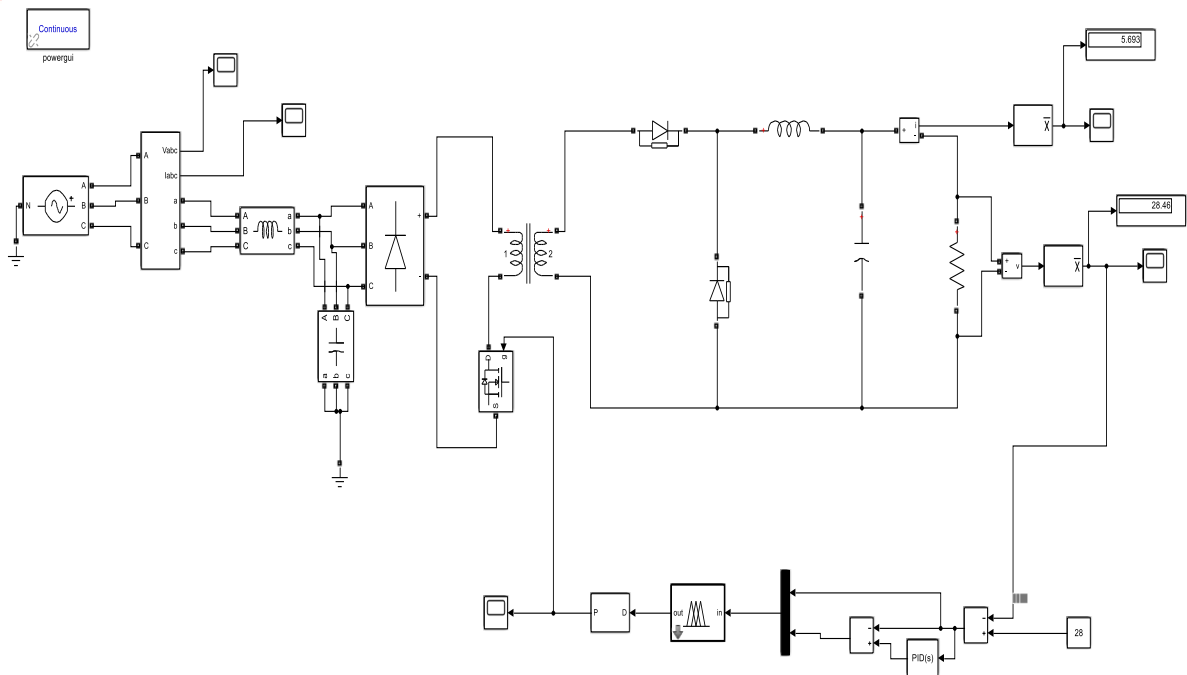

Fig:12. Simulation model of closed loop forward buck converter



### Input Voltage

The input voltage in this paper is nothing but the value of the Ac voltage obtained from the generator of the aircraft which is marked as 400v in the waveform.

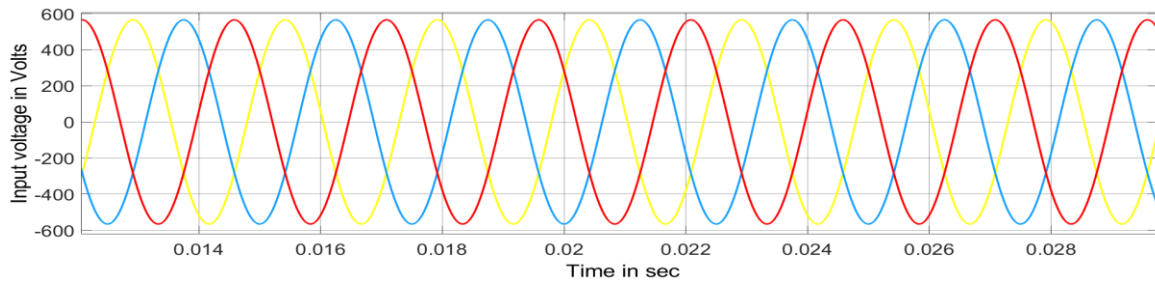

Fig:13. Simulation result of input voltage

### Input Current

The input current in this paper is nothing but the value of the Ac current obtained from the generator of the aircraft which is marked as 11A in the waveform.

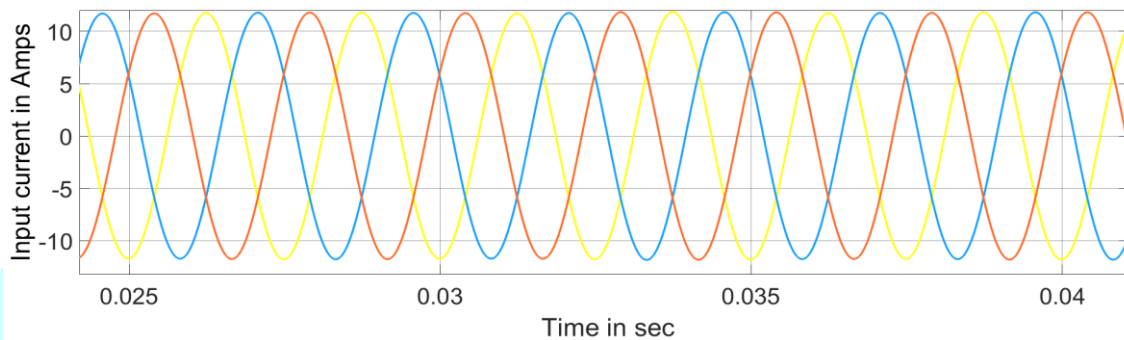

Fig:14. Simulation result of input current

### Output Voltage

The output is the voltage which is measured across the R load and it is given as 28v which is shown by their corresponding waveform.

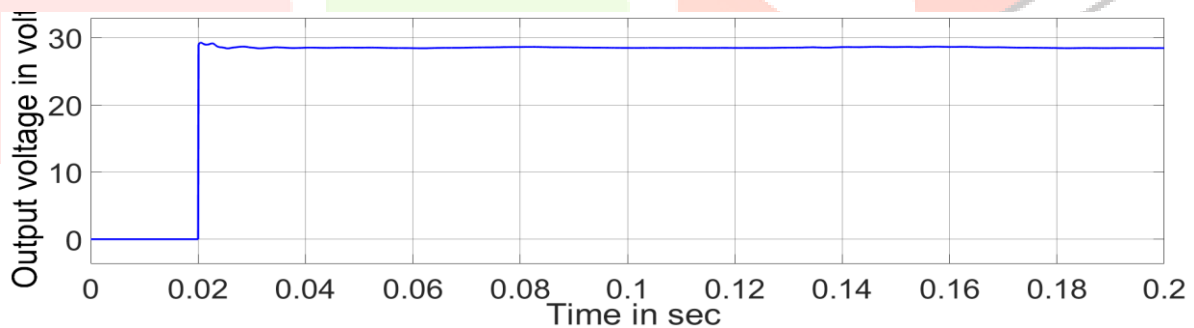

Fig:15. Simulation result of output voltage

### Output Current

The value of the current at the load side is 9A and is represented as output current with their corresponding waveform

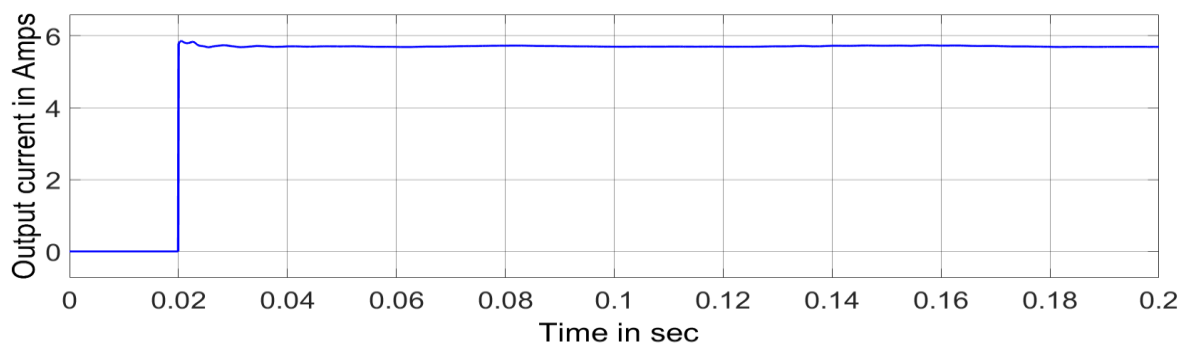

Fig:16. Simulation result of output current

### 5.3 Harmonics

As first harmonics are measured at the input side. The current harmonics at the input side is measured and is known as the line current harmonic. By varying the load, the value of voltage increases as hence the value of line current harmonics decrease. The value of voltage and load is tabulated and given below.

#### Harmonics In The Input Voltage

The following diagram depicts the number of harmonics present within the cycle of input voltage.

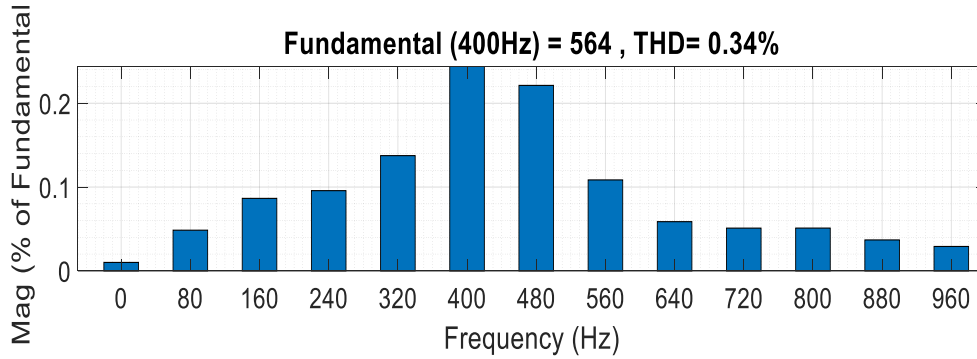

Fig: 17. Harmonics in the Input Voltage

#### Harmonics In The Output Voltage

This fig.18. represents the number of harmonics present within the cycle of input current waveform.

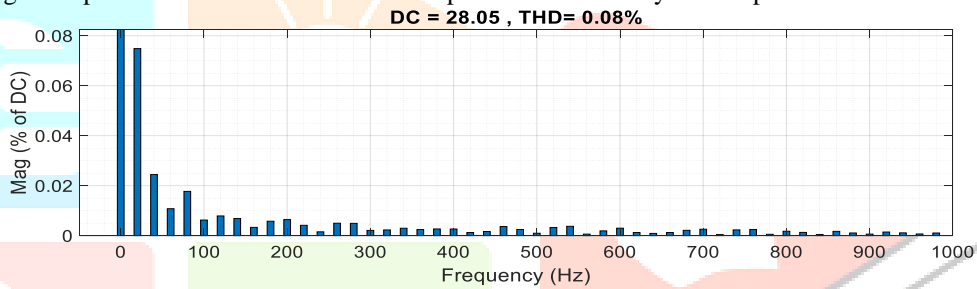

Fig:18. Harmonics in the Output voltage

#### Harmonics In The Output Current

This fig.19. represents the number of harmonics present within the cycle of input waveform.

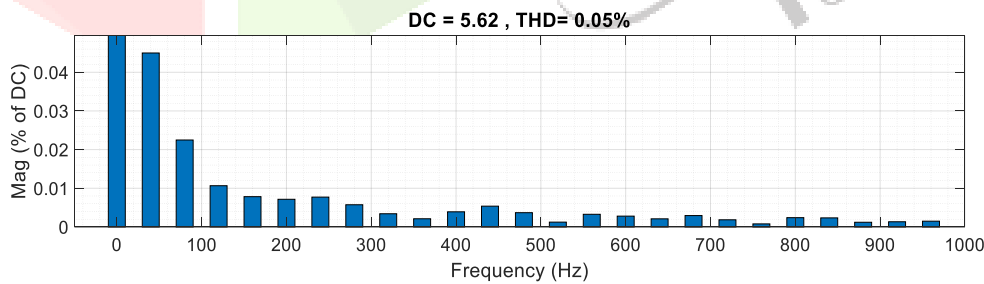

Fig:19. Harmonics in the Output Current

#### Harmonics In The Input Line Current For R = 5 Ω

For R = 5Ω, the value of current harmonics present within the input waveform is determined.

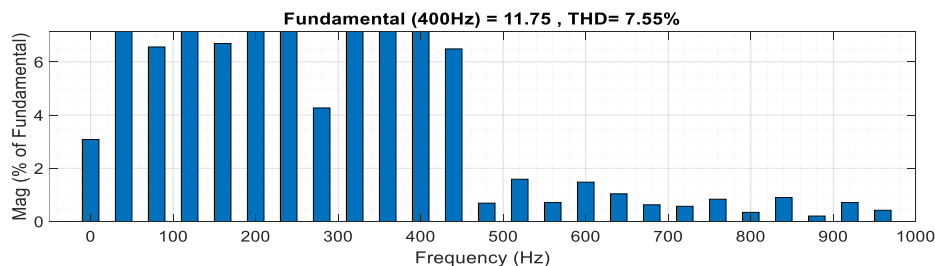

Fig: 20. Harmonics of line current for R = 5Ω

### Harmonics In The Input Line Current For R = 6 Ω

For R = 6Ω, the value of current harmonics present within the input waveform is determined.

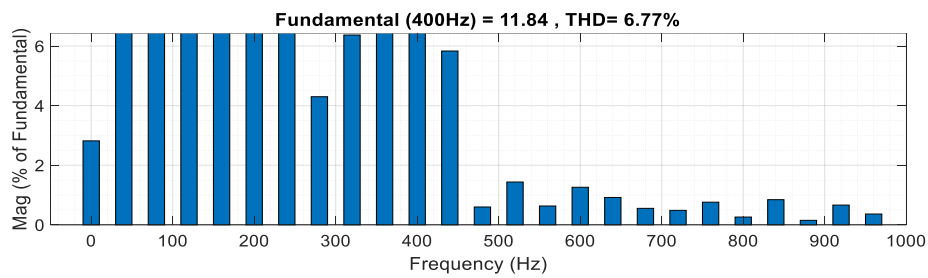

Fig: 21. Harmonics of line current for R = 6Ω

### Harmonics In The Input Line Current For R = 7 Ω

For R = 7 Ω, the value of current harmonics present within the input waveform is determined.

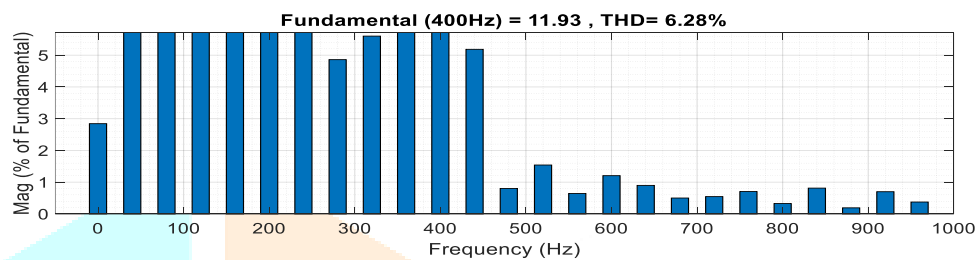

Fig: 22. Harmonics of line current for R = 7Ω

### Harmonics In The Input Line Current For R = 8 Ω

For R = 8 Ω, the value of current harmonics present within the input waveform is determined.

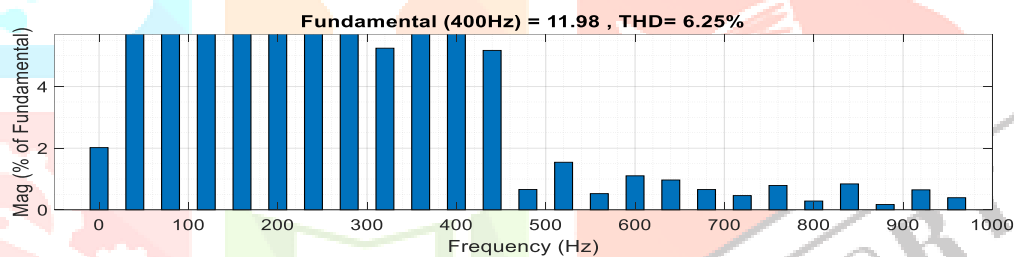

Fig: 23. Harmonics of line current for R = 8Ω

Table. II: Comparison of Harmonics in Input Current with Various R Load.

S. No	Various R Load	Output voltage	Output current	Line current (THD)
1.	R=5Ω	28.05	5.6	7.55
2.	R=6Ω	30.14	31.8	6.77
3.	R=7Ω	31.87	4.5	6.28
4.	R=8Ω	33.72	4.2	6.25

The proposed forward buck converter with input line currents THD is obtained for various R loads 5Ω,6Ω, and 7Ω respectively. Therefore, at the increase load conditions, the line current THD will decrease.

### VI. ACKNOWLEDGMENT

I express the deep sense of gratitude to our beloved Principal (Fac) Dr. C. Vasanthanayaki, M.E., Ph.D., for providing all the facilities and continuous support.

I express my heartfelt thanks to my Supervisor Dr.S. Senthil Kumar, M.E., Ph.D., Professor (CAS) in the Department of Electrical and Electronics Engineering, for her encouragement, guidance and striking suggestions from time to time to complete this project work.

I extend my sincere thanks to our Class Advisor Dr. P. Karpagavalli, M.E., Ph.D., Professor (CAS), Department of Electrical and Electronics Engineering, who had given encouragement and good support at times to complete the project effectively

I convey my sincere and heartfelt thanks to my family members and other teaching and non-teaching staff members and friends, for their support to complete this project.

## VII. CONCLUSION

This paper dealt with the PID based FLC control technique for the effective operation of the forward buck converter. The proposed controlling technique is used for the Forward buck converter in continuous conduction mode. In the future this work can be extended to various converter model and combined with Genetic algorithm, Neural FLC for effective controlling.

## REFERENCES

- [1] Rahul Malhotra, Tejbeer Kaur, "DC motor control using fuzzy logic controller" (IJAEST) Vol. 8, No. 2, pp. 291-296, 2011.
- [2] Heng-yi li, hung-chi chen, member, ieee, and lon-kou chang, member, ieee, "analysis and design of a single-stage parallel ac-to-dc converter", ieee trans on power electronics, vol. 24, no. 12, december 2009.
- [3] A. I. Al-Odienat, A. A. Al-Lawama, "The advantages of PID fuzzy controllers over the conventional types," American Journal of Applied Sciences 5 (6), 2008.
- [4] Joseph S. Subjak, JR and John S. Mcquilkin 'Harmonics - Causes, Effects, Measurements, and Analysis: An Update' IEEE Trans on Industry Appl, Vol.26, No.6, 1990,
- [5] M. Algreer and F. Ali," Position control using fuzzy logic", Al-Rafidain Engineering, Vol. 16, No. 1, 2008.
- [6] C. Ma, D. Huang, "Comparative study of PI controller and fuzzy logic controller for three-phase grid-connected inverter", International Conference on Mechatronics and Automation, Aug. 7-10, 2011, Beijing, China.
- [7] P. Karuppanan and K. Mahapatra , "PI, PID and fuzzy logic controlled cascaded voltage source inverter based active filter for power line conditioners", Wseas Transaction on Power System, Vol. 6, No. 4, Oct. 2011.
- [8] Corcau J. I., Stoenescu E., Tudosie A. The effect of defuzzification method type on the fuzzy logic control of dc to dc converters. 8th WSEAS International Conference on Power, Santander, Cantabria, September 23- 25;
- [9] C. Nagarajan, M. Madheswaran. Performance analysis of LCC – T resonant converter with fuzzy/PID controller using state space analysis. International Journal of electronic Engineering Research, ISSN 0975- 6450, vol. 2, no. 1, pp. 51-70;
- [10] Yigang Shi. Performance improvement of dc to dc converter using fuzzylogic control (FLC). Master of science Engineering, Ontario, Canada 1999.
- [11] yoon choi, moon-hwan keum; sang-kyoo han; jeong-il kang; "high efficiency and high-power factor single-stage balanced forward-flyback converter" in proc. 39th annual conference of the ieee industrial electronics society, iecon 2013, 10-13 nov. 2013. pp 822-827.
- [12] E. H. Watanabe, R. M. Stephan and M. Aredes 'New Concepts of Instantaneous Active and Reactive Powers in Electrical Systems with Generic Loads' IEEE Trans on Power Delivery, Vol.8, No.2, 1993, pp.697-703.
- [13] Christopher K. Duffey and Ray. P. Stratford 'Update of Harmonic Standard IEEE-519: IEEE Recommended Practices and Requirements for Harmonic Control in Electric Power Systems' IEEE Trans on Industry Appl, Vol.25, No.6, 1989, pp.1025-1034
- [14] S. A. Gonzalez, R. Garcia-Retegui, and M. Benedetti 'Harmonic computation technique suitable for active power filters' IEEE Trans on Ind. Electron, vol.54, No.5,2007, pp. 2791–2796