



# INTERNATIONAL JOURNAL OF CREATIVE RESEARCH THOUGHTS (IJCRT)

An International Open Access, Peer-reviewed, Refereed Journal

## SELF-BALANCING SEMI-AUTOMATIC TABLE

<sup>1</sup>G.Rakkesh Aravind, <sup>2</sup>Mrs.V.Priya, <sup>3</sup>S.Sathish Kumar, <sup>4</sup>S.Dinesh Kumar, <sup>5</sup>P. NAGARAJ

<sup>1</sup>UG Student, Mechatronics Department, Bharath Institute of Higher Education and Research, BIHER

<sup>2</sup>Assistant Professor, Department of Mechatronics, Bharath Institute of Higher Education and Research, BIHER

<sup>3</sup>UG Student, Mechatronics Department Bharath Institute of Higher Education and Research, BIHER

<sup>4</sup>UG Student, Mechatronics Department Bharath Institute of Higher Education and Research, BIHER

<sup>5</sup>UG Student, Mechatronics Department Bharath Institute of Higher Education and Research, BIHER

Mechatronics Department

Bharath Institute of Higher Education and Research (BIHER)

173, Agharam Road, Selaiyur, Chennai-600073, Tamil Nadu, India.

**Abstract:** We have implemented the technique of Self-Balancing Technology with the Principle of Gyroscope to a Table. It is semi-automated and can be fully automated too, movable, compact, rigid machine that makes the table move in upward, downward and sideward directions, while the table can be stable and upright position. To Develop a design that shall be used for Purposes of works inside gravitational mediums like Medical, Manufacturing and outside the gravitational, like in space exploration mission. It's all controlled by An Arduino Mega microcontroller, a Six-Axis motion tracking device MPU, 6050 accelerometer and Gyroscope. The controller is made in such a way that it maintains the prototype at an initially selected angle when the support structure orientation changes as per the required.

**Index terms:** Arduino Uno Microcontroller, MPU 6050, Accelerometer, Gyroscope, Self-stability, Orientation angle

### I. INTRODUCTION

A self-balancing semi-automated table comprises of two Divisions Top and Bottom, each consisting of three main parts including sensors, logical processing unit and actuator. In this project, the table can maintain an upright and balanced position on any platform and maintain to keep the products kept on top intact, is designed and developed. This table consists of Inertial Measurement Units (IMU) sensors, microprocessor and motors. The Principle purpose of the controller is to fuse the wheel, gyroscope and accelerometer sensors to calculate the attitude of the platform and then to use this information to drive the action wheel in the direction to maintain an upright and balanced position, and at the same time there's another microprocessor at the top act accordingly combining information from the bottom circuit and keeps the Object/Load stable on its top. In this project, we use PID because of it's easy to implementation and practical to use.

The controller has three fully adjustable parameters that's used to determine the output several techniques. Gyro sensor is used in self-balancing Table, continuously sends the robot orientation data to the controller. On the basis of this data controller command the motor to run forward or reverse to maintain the position of robot up straight. The main idea which was driving us to make a self-balancing semi-automated was to go help in places where man cannot go or there's a need of a product of a load to be delivered in order to help the people or to complete the set of event need to finish an operation or a work.

This Self- Balancing table can be used in industries where the raw materials are heavy and proper handling is must, or the temperature of the material is so high that it needs more than man power, in low gravity situations like under water and space exploration, and in all-terrain army and Defence application, Since it's a Self-balancing robot, it is designed to balance itself on two wheels, by constantly made to correct its position with the help of a Gyro sensor, which is used in self-balancing robot. It continuously sends the robot orientation data to the controller. On the basis of this data controller command the motor to run forward or reverse to maintain the position of robot up straight.

## II. BLOCK DIAGRAM

With help of position monitoring in pc using processing control, the pc is data is send and receive data from microcontroller through serial port. The Inven Sense MPU6050 chip we used has a 3.3V IC, with an approved working voltage range of 2.4V-3.4V, from the schematics above, the GY-521 breakout board has a good built in low drop-out voltage regulator, and it's safe to power the chip through the Arduino 5V rail. This is due to the voltage drop from the regulator on the VCC line, using the Arduino 3.3V rail may not provide enough voltage. We tested powering the chip both with 3.3V and 5V but in the 5V input the Arduino did more successfully.



Figure: 1 Complete Circuit Diagram

## III. HARDWARE

### 3.1 Servo Motors

A stepper motor is an electric motor whose main program is its shaft rotates by performing steps, that is, by moving by a fixed amount of degrees. This feature is obtained thanks to the internal structure of the motor, and allows to know the exact angular position of the shaft by simply counting how many steps have been performed, with no need for a sensor. This feature also makes it fit for a wide range of applications. Stepper motors consist of a stationary part (the stator) and a part that moves (the rotor). The teeth on stator coils are wired, while the rotor is either a permanent magnet or a variable reluctance iron core. It typically has a stationary set of magnets on the stator and an armature with a series of two or multiple windings of wire wrapped in an insulated stack slots around iron pole pieces with the ends of the wires terminating on a commutator successfully, but in the 5V input abstract. We use NEMA 17 hybrid stepping motor equipped with a 1.8° step angle (200 steps/revolution). Each and every phase draws 1.2 A at 4 V, allowing for a holding torque of 3.2 kg-cm. It is generally used in Printers, CNC machines and Laser Cutter.

### 3.2 3-Axis Accelerometer/Gyroscope (MPU 6050)

We used the Gyroscope in our project because of the principles of angular momentum it follows. Mechanical type of gyroscopes are typically consist of a spinning wheel or disc in any which the axle is free to assume or take any orientation. Gyroscopes works on other operating principles than the usual operating principles, such as the electronic, microchip-packaged MEMS gyroscope devices found in consumer electronic devices, solid-state ring lasers, optical fibre gyroscopes, and the extremely high sensitive quantum gyroscope. The MPU6050 Sensor which includes both a 3 axis accelerometer and a 3 axis and can be interfaced through a I2C connection which allows an easy and direct interface between the sensor and a micro controller. It has 6 Degrees of Freedom and the sensor breakout is integrated with MPU6050 sensor and so the low noise 3.3v regulator and pull-up resistors for the I2C bus.

### 3.3 A4988 Stepper Driver IC

We used the A4988 stepper motor driver it has an output drive capacity of up to 35 V and current of  $\pm 2A$ . It help to control the one bipolar stepper motor at up to 2A output current per coil like in stepper motors such as NEMA 17. The driver has built-in translator for easy operation. This reduces the number of control Pins serves for 2 purposes, one for controlling the steps and other for controlling spinning direction. The Driver offers 5 different step resolutions viz. full-step, half-step, quarter-step, eighth-step, and sixteenth-step. The A4988 is used because of its complete Micro stepping Motor Driver abilities with built-in translator for easy operation. The driver has a maximum recommended output capacity of 35 V and  $\pm 2 A$ . It is used to operate bipolar stepper motors in several mode such as full-, half-, quarter-, eighth-, and sixteenth-step modes. This motor driver is rated of low-ESR ceramic capacitors on board, which makes it vulnerable to voltage spikes, so we use at least 47 $\mu$ f capacitor across motor power supply pins. Stepper Motor wires is connected with output pins named as 1A, 1B, 2A & 2B in the driver module.

### 3.4 Arduino Uno

We used the best Prototyping board out there Arduino Uno, it is a microcontroller board based on 8-bit ATmega328P microcontroller. Along with ATmega328P, it has highly useful components such as crystal oscillator, serial communication, voltage regulator, etc. To support the microcontroller. Arduino Uno has 14 digital input/output pins, out of which 6 can be used as PWM outputs, 6 analog input pins, a USB connection, A Power barrel jack, an ICSP header and a reset button.

### 3.5 HC-05 Bluetooth Module

It is a duplex wireless functionality which is used to communicate between two microcontrollers or communicate with any device with Bluetooth functionality. Android applications makes this process a lot easier. The module communicates with the help of USART at 9600 baud rate hence it is easy to interface with any microcontroller that supports the same. Bluetooth module helps in improving the connectivity a lot better than anything. It give the accurate work done or the progression of the work that the table is assigned to. It ensures that all the instructions are processed and keeps the history of working to improve its accuracy and also to find some bugs in the system.

### 3.6 Voice Recognition Module V3

The Voice Recognition Module we used in our prototype is from Elechouse, which is a compact yet easy-control speaking recognition board. It is a speaker-dependent voice recognition module and supports up to 80 voice commands in all. With a maximum of 7 voice commands could work at the same time. Any sound could be trained as command. The module need to be trained first before let it to recognize any voice command.

### 3.7 Li-Po Battery

The battery we used here is a 12 v Li-Po one, which has a good energy density and can be used for a longer period of time than the typical work time. This type of battery is required because of the constant working of sensors which key to run the entire system.

## IV. SOFTWARE

### 4.1 Arduino Processing Software

We used an open-source physical computing platform based on a simple microcontroller board, and a development environment for writing software suitable for the design and designation of the board. It is used to develop the best interactive devices with robotic applications and its taking inputs from a variety of devices like switches, sensors, and controlling a variety of lights, motors, and other physical outputs. They can be stand-alone, or they can communicate with software running on pc. The boards can be assembled by hand and the open-source IDE can be downloaded and can be feed directly into it with help of a PC. The Arduino programming language helps to implement the data of Wiring, which is a similar physical computing platform, based on the Processing multimedia programming environment enabled by the Arduino Board.

### 4.2 Processing Software

We used the python oriented processing software to decode the data from the Microcontroller to the PC. It has a software literacy within the visual arts and visual literacy within technology. It was created to serve as a software sketchbook and to teach computer programming fundamentals within a visual context, then it went through a lot of processing to be evolved into a development tool for professionals. It is efficient for prototyping and production.

## V. Methodology

There's a need of futuristic and yet affordable innovation on simple structures like table, so we designed a prototype based on the need for high productivity and to decrease the work time, yet it should look minimalistic in nature. A self-balancing semi-automated table consists of three main parts the sensors, the logical processing unit and the actuator. This table is designed and developed made to be in an upright and balanced position on a platform, and hold the object without falling, solely for that purpose. The Table consists of Inertial Measurement Units (IMU) sensors, microprocessor and motors.

First the table moves on with help of the Motors fitted in bottom compartment with the signals from the microcontroller which uses the by MPU6050 Gyroscope sensors to detect the angle of in inclination and declinations and move the table according to the data collected by it. The sensors always ensures that the Table is in right position ( $90^\circ$ ), that's the ideal and default position of the table. It acts as Primary angle and any Deflection from it is accounted as an Information from the sensors and are sent to the Arduino UNO microcontroller, which are encoded by the microprocessors and response data is sent to the corresponding motor drivers as inputs and the rectification of the required position takes place.

Arduino now do PID calculation as instructed and commands the stepper motor to run in forward direction to minimize the tilt angle upto zero degree and gives commands until the desired the required angle is obtained in given time. The motor moves forward and reverse more than 400 times per second, so its looks like table is stable at its place. This process continues as long as the table is in the running position or in working mode. Now to the Top compartment of the Table. The Top compartment consist of Two Servo motors working together in carrying the load perfectly and safely to the required place and position. This process is carried out by the same principle of the operation takes place in the Bottom Compartment.

The Gyroscopic sensors present in there supervises the change in angle of the object when the position in the bottom changes due to inclination or declination of the angle based on the irregular surface on which it moved on as a path of travel to reach the desired location on time. This makes little jerks and makes the product or the load on the Top unstable, so the data's collected from the specific sensors in the top compartment is decoded to the microcontroller and the that micro controller sends output data to maintain the surface in  $180^\circ$  is sent to the two servo motors drivers respectively. They both take the instructions from the microcontroller and maintains the position to be in  $180^\circ$  and report the angle position in every half second to every second until the required angle is obtained and to ensure the safety and handling of the load is counted. The microcontroller is assigned to make the process as quick and less time consuming. The Top and Bottom compartment, they both work together and are synchronised by the microprocessors. The Sensors are also made to work in such a way that they yield accurate results in plotting the positions and ensure the time lag between the Top and Bottom is on null or negotiation side. This is the working process and the methodology of the self-balancing semi-automated table. The main purpose of the controller is to fuse the wheel, gyroscope and accelerometer sensors to estimate the attitude of the platform and then to use.

This information to drive there action wheel in the direction to maintain an upright and balanced position, after that it finds the level of top surface where objects are kept and use the gyroscope readings to reduce the juggle caused by the surface on which the table moves. In this project, the PID will be used because it is easier to implement, practical and has better affordability. The PID controller limited to three adjustable parameters that is used in several techniques. The Control System is designed in such a way to improve stability, speed of response, steady-state error, or prevent oscillations. A lot of Researchers wants to produce a mathematical equation that determines the apt position of a very accurate motor position, thus the steady state error should be zero. Addition of Voice Recognition Module is helps to control the prototype to move forward and reverse direction, to adjust the height and to hold the load in plan. Altogether is what the heart of our self-balancing Table is.

### 5.1 Circuit Diagrams

#### 5.1.1 Circuit Connection with A4988 Motor Driver

It's done by connecting VDD and GND to the 5V and ground pins on the Arduino. DIR and STEP input pins are connected to #2 & #3 digital output pins. The pin are connected to the appropriate connecting spots and checked twice.

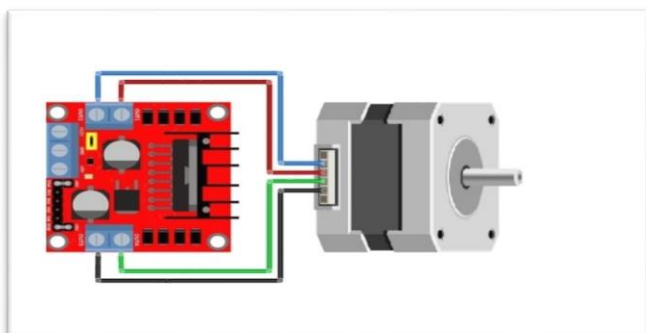

Figure: 2 Stepper Motor and A4988 Motor Driver

### 5.1.2 Circuit Connection with MPU 605

Connect the module's VCC to the Arduino's 5V pin. Then, the module's GND is connected to one of the GND pins. Next, we have to set up the I2C connection between the module and the Arduino by just connecting SCL to SCL and SDA to SDA. Carefulness while connecting is required while connecting the sensitive wires.

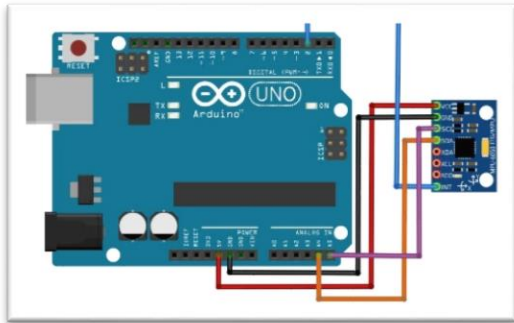

Figure: 3 Arduino with MPU 6050 Gyro Sensor

### 5.1.3 Circuit connection with Motor and A4988 Motor Driver

Connect the stepper motor to the 2B, 2A, 1A & 1B pins. A4988 is conveniently laid out to match the 4-pin connector on several bipolar motors. Connect RST pin to the adjacent SLP/SLEEP pin to keep the driver enabled. Also keep the micro step selection pins disconnected to operate the motor in full step mode. Connect the motor power supply to the VMOT and GND pins. Then a large 100 $\mu$ F decoupling electrolytic capacitor is put across motor power supply pins, close to the board.

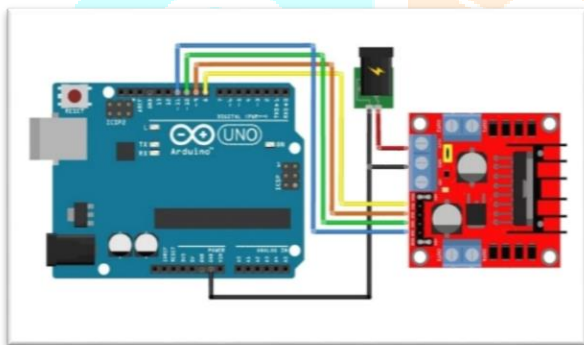

Figure: 4 Arduino Uno with A4988 Motor Driver Controller

### 5.1.4 2D Model

The 2D Model show the pictorial representation of the placement of parts and position of the respective sensors. This helps us easily understand the dynamics of the project.

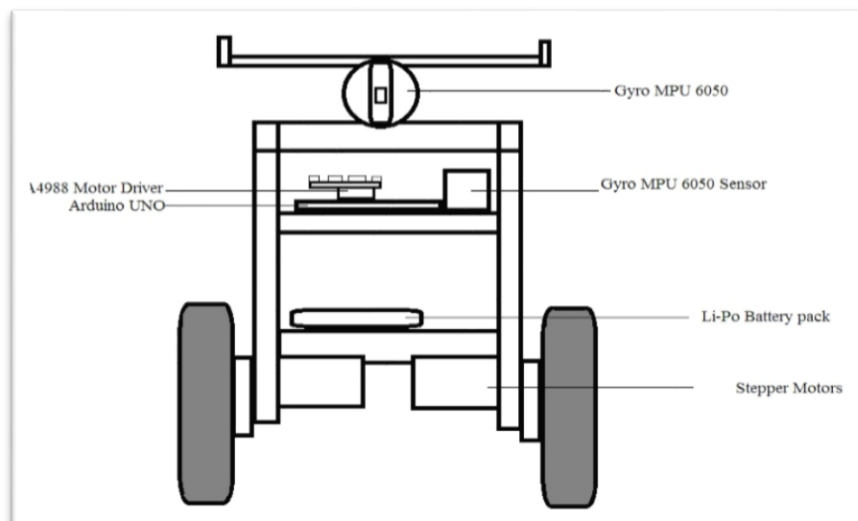

Figure: 5 2D Model Representation



### 5.1.5 3D Model

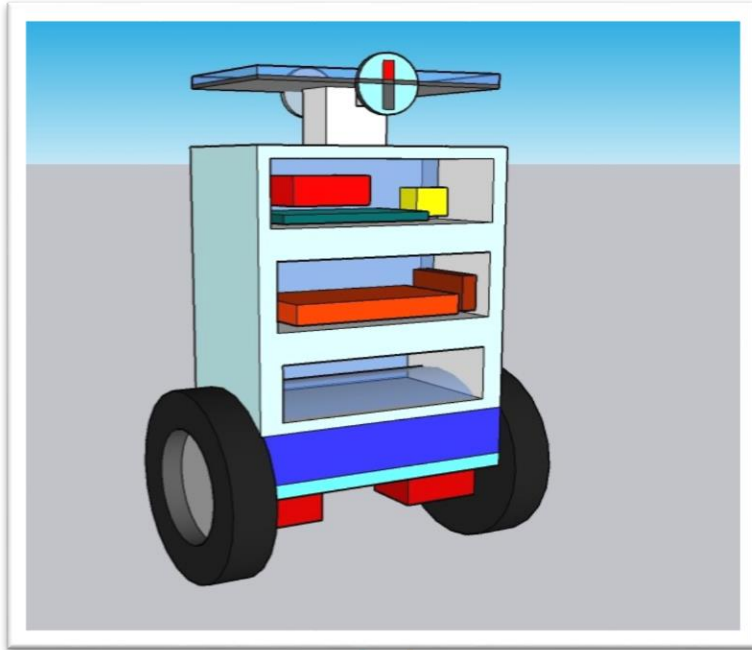

Figure: 6 3D Model Representation

The 3D depiction of how our Self Balancing and Semi Automated table

The Bottom red one depict the Nema 17 Servo motors, the wheels are rigid 10 Cm each with a grip on a surface with limited inclination angle. The blue box hold the accessory cables, and hold the charging port.

Above the Orange is the battery pack, which houses 12v Dc 2000mAh battery. The top rack holds the microprocessors (Teal) the Motor Controller (Red) and the sensors (yellow)The top most houses the another set of motors and sensors which carefully takes care of the Object/Load which is places on it.

## VI. CONCLUSION

To build a self-balancing semi-automated table, The PID controller is designed in such a way to control the close loop function. The controllability has been taken into account and set the pole location. For analysis and algorithm we used the Kalman Filter as an estimator and predictor.

Then by choosing the appropriate components we analyses their simulation successfully. So by implementation all of these concepts and avoid the errors the self-balancing semi-automated table is completely built. We did test runs on the program multiple times until the desired results were obtained, then it was made to reach and maintain constant results.

## VII. REFERENCE

- [1] R.S.Meena Vikas Kumawat (2011) .Controller Design for Servo Motor Using MATLAB .In Proceeding of National Conferences on Advances & Research in Electrical System Technology (AREST 2011)
- [2] Popescu, Cristina; Paraschiv, Nicolae; Cangea, Otilia. (2011) Comparison between PID and Fuzzy Controllers Used In Mobile Robot Control Annals of daaam & proceedings; jan2011, p223.
- [3] Kotaki, Masakazu; Yamakawa, Yuji; Yamazaki, Takanori; Kamimura, A Tuning Method for PID Controller That Considers Changes in System Characteristics. ASHRAE Transactions. 2005, Vol. 111 Issue 2, p13-22
- [4] Arpit Goel., et al. (2012) Performance Comparison of PID and Fuzzy Logic Controller Using Different Defuzzification Techniques for Positioning Control of DC Motors. Journal of Information Systems and Communication ISSN: 0976-8742 & E-ISSN: 0976-8750, Volume 3, Issue 1, pp.-235-238.
- [5] Young Soo Suh.(2003) .Attitude Estimation Using Low Cost Accelerometer And Gyroscope. Proceedings KORUS 2003. The 7th Korea-Russia International Symposium on Volume: 2 Page(s): 423 - 427 vol.2
- [6] Andrea Demetlika, Tomislav Tomašić, Mladen Crneković (2012)Self-balancing Mobile Robot Tilter.FAMENA issue 3, volume 36, Zagreb.

- [7] Hany Ferdinando, Heri Saptono Warpindyasmoro, Stanley Kardinal Jusuf.(2001) Developing Mathematical Model of DC Servo Motor Using Bond Graph 1st Ketingan Physics Forum, Surakarta
- [8] V.J. VanDoren, "PID: Still the One," Control Engineering, October 2003. Retrieved
- [9] D. Simon, Kalman Filtering With State Constraints: A Survey of Linear And Nonlinear Algorithms, IET Proceedings in Control Theory & Applications ,vol. 4, no. 8, pp. 1303-1318, 2010.
- [10] Braun, T., Sutherland, and Alistair (2002).An Experimental Platform for Researching Robot Balance. Department of Electrical & Electronic Engineering .University of Western Australia

