



# TVOC AND CO<sub>2</sub> MEASUREMENT USING CCS811 AIR QUALITY SENSOR

<sup>1</sup> Kavya Akunuru, <sup>2</sup> Mantri Sindhu, <sup>3</sup> Maduri Snigdha, <sup>4</sup> Nagapuri Pranali  
<sup>1</sup> Graduation Student, <sup>2</sup> Graduation Student, <sup>3</sup> Graduation Student, <sup>4</sup> Graduation Student,  
<sup>1,2,3,4</sup>Electronics and Communication Engineering  
<sup>1,2,3,4</sup>Balaji Institute of Technology and Science, Warangal, India

**Abstract:** “Sadly, in the name of progress, we have polluted the air, water, soil and the food we eat”. So, monitoring the air quality is very crucial now days because of pollution. For designing an air quality monitoring system, we need durable and reliable air quality sensor. Although there are many Air Quality parameters but the most important are CO<sub>2</sub> and TVOC. So, for sensing CO<sub>2</sub> and TVOC, we are using **CCS811 Air Quality Sensor**. CCS811 manufactured by AMS is a digital CO<sub>2</sub> and TVOC air quality sensor. Main measurement characteristics: equivalent carbon dioxide range is 400ppm up to 29206ppm; equivalent Total Volatile Organic Compounds output range is from 0ppb up to 32768ppb; internal compensation algorithm using external ambient temperature and humidity data source; temperature range for operation -40C to +80C.

**Index Terms -** Arduino, Air quality sensor, CCS811, CO<sub>2</sub>

## I. INTRODUCTION

Now-a-days air pollution is one of the most important concern of the world. Air pollution may evolve from anthropogenic or natural sources. Air pollutants of atmospheric substances like CO, CO<sub>2</sub>, SO<sub>2</sub>, NO<sub>2</sub>, and O<sub>3</sub> suspended particulate matter (SPM), respirable suspended particulate matter (RSPM), and volatile organic compounds (VOCs) have a great effect on the people health. Most of the major cities in developing countries and most cities of the developed countries are suffering from it. Thus, to develop a real time air quality and pollution monitoring system is critical. We have developed an Arduino based air pollution detector which combined a small-sized, minimum-cost sensor to an Arduino microcontroller unit. The advantages of the detector, have a reliable stability, rapid response recovery and long-life features. It is affordable, user-friendly, low-cost and minimum-power requirement hardware which is appropriate for mobile measurement, as well as comprehensible data collection. It has a processing software able to analyze, collected quality data with high precision. Simple instrument which can be commercially utilized.

## II. Methodology

In our circuit, we are using this sensor for sensing TVOC and CO<sub>2</sub> available in the environment and displaying the data on 16\*2 LCD. we have set up LCD and CCS811 air quality sensor and calibrated it for the showing correct temperature. we used functions “*ccs.available()*” (Function is already defined in library) to check if there is some data coming. As we get the data, we are able to calculate the temperature and display it on 16\*2 LCD. Further if CCS is available and *ccs.readData()* is returning false then we get the CO<sub>2</sub> value using function *ccs.getCO2()* and TVOC value using *ccs.getTVOC()*, as shown in the below code. Hence, we have received the value of air quality parameters using CCS811 air quality sensor. CCS811 Air Quality Sensor is an ultra-low power digital gas sensor which integrates a MOX (metal oxide) gas sensor to detect a wide range of VOCs (Volatile Organic Compounds) for indoor air quality monitoring with an integrated MCU (Microcontroller Unit). MCU consists of ADC (Analog-to-Digital Converter) and I2C interface. Those all parts are associated as appeared in figure 2(a).

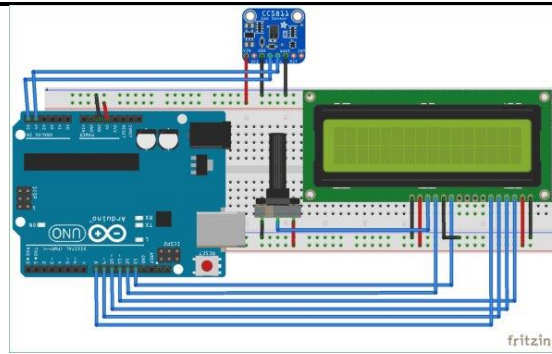

**Fig2(a)-circuit diagram of Tvoc and Co2 Measurement using air quality sensor**

It's based on an **ams** unique micro-hotplate technology which empowers highly reliable solutions for Gas Sensors, with low power consumption.

The major components are as follows:

1. Arduino Uno
2. LCD 16\*2 Display
3. CCS811 Air Quality Sensor

### III. Architecture of the Device

A harmful gas recognition device for the people, the environment that is appropriate for. A wide variety of gases is detected in air quality sensor comprising  $\text{NH}_3$ ,  $\text{NO}_2$ , benzene, alcohol, smoke, and  $\text{CO}_2$ . The collection of air pollutants like  $\text{CO}_2$ ,  $\text{CO}$ ,  $\text{SO}_2$ , etc. is greatly location- dependent [3, 6, 9, 12]. Very simple device, and monitoring circuit which is perfect for use in office or factory We have also developed a customize software s for gathering data from the detector and mapping it in real- time [10, 13]. The software of Arduino-based air pollution detector system comprises the coding of the Arduino Uno board in its Integrated Development Environment (Arduino IDE). The serial connection between the sensor, the Arduino, and the computer system that was formed.

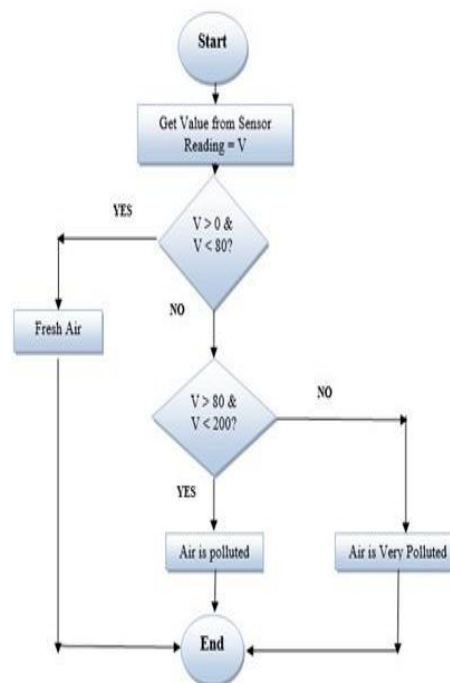
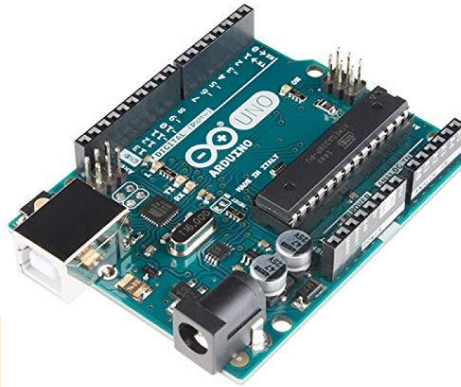

**Fig3(a). Flow chart**

#### IV. Description of Hardware

##### 1. Arduino Uno: -

Arduino Uno is a microcontroller chip reliant on the Atmega328(datasheet) with 14 modernized I/o pins, in which 6 pins can be used as yields, 6 pins are used as straightforward data sources. It has 16 MHz earth resonator, a USB affiliation, a force jack and a reset button. The microcontroller has 32kB of ISP streak memory, 2kB RAM and 1kB EEPROM. The board gives sequential correspondence capacity through UART, SPI and I2C. Because of well plan the Arduino is straightforward. In Arduino we utilize significant level of programming language like C language, C++ language etc. It is straightforward and easy to use language. It has a lot of favourable position like performing multiple tasks, robotization, time area and so on. Arduino Uno fig4 (an) is given underneath.



**Fig 4(a)- Arduino Uno**

##### 2. CCS811 Air Quality Sensor: -

CCS811 Air Quality Sensor is an ultra-low power digital gas sensor which integrates a MOX (metal oxide) gas sensor to detect a wide range of VOCs (Volatile Organic Compounds) for indoor air quality monitoring with an integrated MCU (Micro-controller Unit). MCU consists of ADC (Analog-to-Digital Converter) and I2C interface. It's based on an ams unique micro-hotplate technology which empowers highly reliable solutions for Gas Sensors, with low power consumption

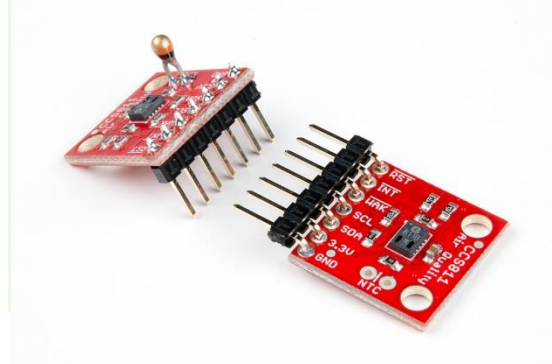

**Fig 4(b) Bluetooth HC-05.**

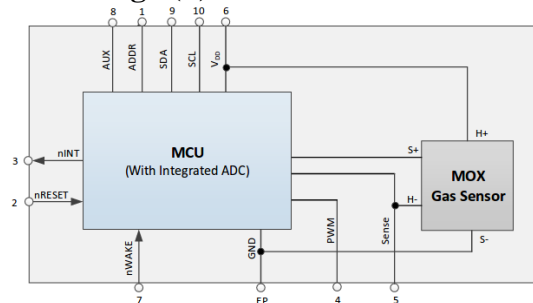

The CCS811 has 5 modes of operation as follows • Mode 0: Idle, low current mode • Mode 1: Constant power mode, IAQ measurement every second • Mode 2: Pulse heating mode IAQ measurement every 10 seconds • Mode 3: Low power pulse heating mode IAQ measurement every 60 seconds • Mode 4: Constant power mode, sensor measurement every 250ms In Modes 1, 2, 3, the equivalent CO<sub>2</sub> concentration (ppm) and TVOC concentration (ppb) are calculated for every sample. • Mode 1 reacts fastest to gas presence, but has a higher operating current • Mode 3 reacts more slowly to gas presence but has the lowest average operating current. When a sensor operating mode is changed to a new mode with a lower sample rate (e.g. from Mode 1 to Mode 3), it should be placed in Mode 0 (Idle) for at least 10 minutes before enabling the new mode. When a sensor

operating mode is changed to a new mode with a higher sample rate (e.g., from Mode 3 to Mode 1), there is no requirement to wait before enabling the new mode.

### 3. LCD (16/2): -

An LCD (Liquid Crystal Display) screen is an electronic display module and has a wide range of applications. A 16x2 LCD display is very basic module and is very commonly used in various devices and circuits. A 16x2 LCD means it can display 16 characters per line and there are 2 such lines. In this LCD each character is displayed in 5x7 pixel matrix. The 16 x 2 intelligent alphanumeric dot matrix display is capable of displaying 224 different characters and symbols. This LCD has two registers, namely, Command and Data.

The figure 4(c) of LCD is given below.

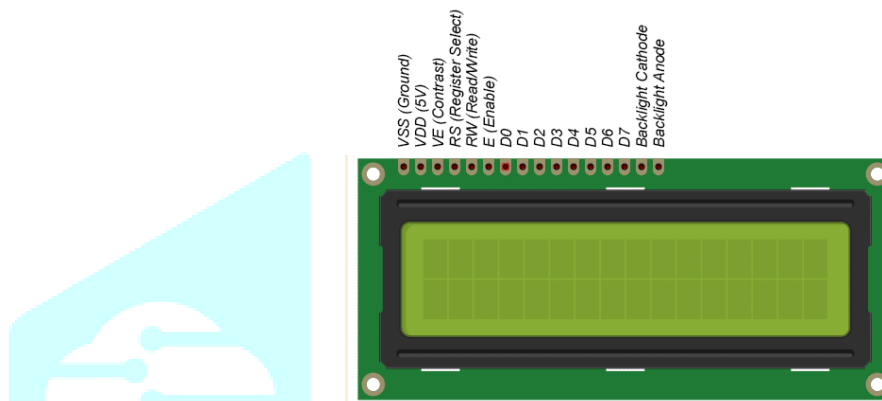

Fig 4(c) LCD 16\*2 Display

### V. Advantage

- Economic
- Experimental Versatility
- Pedagogical Versatility

### VI. Result

As indicated by the proposed arrangement the ultimate result of this paper prompts the advancement of a home mechanization. Through this undertaking, a computerization framework has been made with the goal that we can undoubtedly control home machines like as light, fan, tube light, AC, bulb, and so on. One of the goals of this task is likewise to get us a shrewd robotization and minimal effort venture. In this paper we have likewise given data about Arduino Uno, Bluetooth regulator and hand-off module. Also, the data about their work is given. Alongside the segment of home computerization, its preferred position has likewise been examined. The framework is simple and made sure about for access from subterranean insect client or gate crasher. Ultimate result of the undertaking is given underneath in fig 5(a)(b)(c)(d).

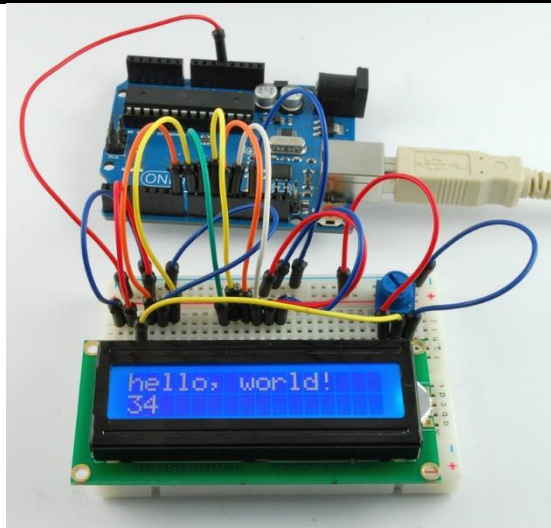

Fig 5(a) Arduino with LCD

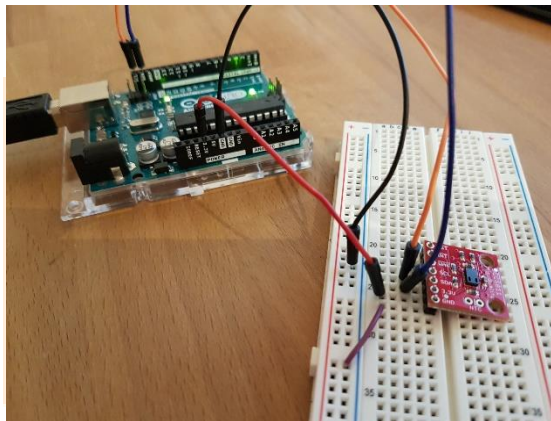

Fig 5(b) Arduino with CCS811

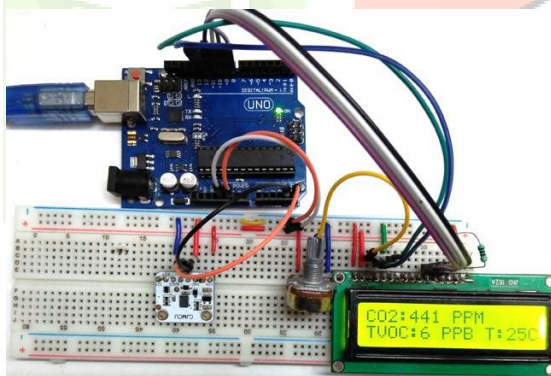
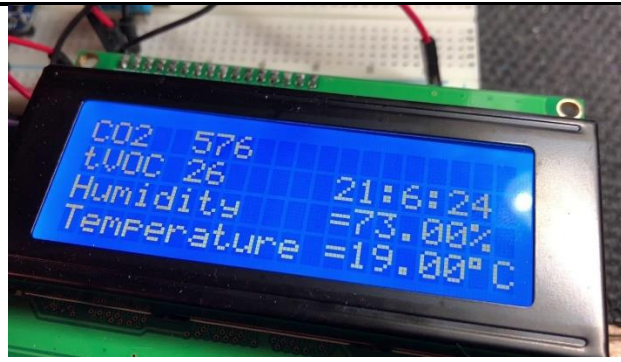

Fig 5(c) Connections

```
COM1 (Arduino/Genuino Uno)
Air is poluted
Air quality= 72 PPM
Limit= 1
Fresh Air
Air quality= 124 PPM
Limit= 1
Air is poluted
Air quality= 80 PPM
Limit= 1
Air is very poluted.Leave the place
Air quality= 86 PPM
Limit= 1
Air is poluted
Air quality= 118 PPM
Limit= 1
Air is poluted
Air quality= 75 PPM
Limit= 1
Fresh Air
Air quality= 96 PPM
Limit= 1
```



**Fig 5(d) Result**

## VII. Conclusion

We have developed an Arduino based air pollution detector which is a very effective air pollution monitoring system. Based on the performance we can say that it is easy to use, and functionality is comparable to the expensive existing air pollution detectors. It is a microcontroller based portable system. It is efficient and user-friendly air quality detection system. Arduino based air quality monitoring detector system design involves hardware and connection and finally the collection of data from the detector through code for the Arduino. To obtain real time air pollution data (in PPM), we have taken reading using our customized sensor- detector in different environmental pollutions. We have used cigarette smoke, coil burning smoke, vehicle smoke from street etc.

## VIII. References

- ✓ [www.arduino.cc](http://www.arduino.cc)
- ✓ [www.wikipedia.org](http://www.wikipedia.org)
- ✓ [www.electronicshub.org](http://www.electronicshub.org)
- ✓ [www.electronicsworldforyou.com](http://www.electronicsworldforyou.com)
- ✓ [www.circuitdigest.com](http://www.circuitdigest.com)

