



## 360 DEGREE WHEEL ROTATION VEHICLES

Sarvind Kumar<sup>#1</sup> Anurag Ranjan<sup>#2</sup> Ujjawal Kumar<sup>#3</sup>, Divakar Kumar<sup>#4</sup>, Dhruv Kumar<sup>#5</sup>,

#1UG Student, #2UG Student, #3UG Student, #4UG Student , #5Assistant Professor

Deptt. Of mechanical engineering, Jims engineering management technical campus, greater Noida, Uttar Pradesh-201308

**ABSTRACT-** The project is about 360-degree rotating vehicle. This vehicle moves in all directions. This makes the vehicle suitable for operation in narrow paths and sharp corners. The normal wheel vehicles face lot of problems like parking, U turn and much more which consumes more time. So, a 360-degree wheel rotating vehicle is designed to reduce and eliminate problems that occur when handling material in the industries. In this system, each of the 4 wheels has given drive with stepper motors, so it can rotate 360 degree. There are 4 Dc motors drive to move the vehicle in forward and reverse directions. 360-degree rotating wheel is controlled by RF remote. Accordingly, we will use this 360-degree rotating vehicle for different perspectives wish to transport things overpowering bags and additionally in vehicles, which can help in decreasing hour gridlock and spare time.

### I. INTRODUCTION

This project is about plan of 360 degree wheel turning vehicle. This vehicle moves every which way and this plan gives better solace and furthermore spares the season of clients, the vast majority of the general population utilizing this vehicle to convey products, understanding and so on. In any case, more often than not, they need to confront the issue like taking U turn and so forth. So need to structure a 360 degree wheel turning vehicle to lessen and dispose of issues in the business and at the railroad stage. This structure will give better solace and furthermore spares the season of clients, that is the reason it is additionally the dependable for the client. As it is likewise battery worked vehicle consequently no fuel is required. Consequently it is affordable to the earth. This will likewise diminish the expense of the vehicle. Zero degree turning span of a vehicle suggests the vehicle pivoting around a hub going through the focal point of gravity of vehicle for example the vehicle turning at a similar spot, where it is standing. No additional room is required to turn the vehicle. So vehicle is to be turned in the space equivalent to the length of the vehicle itself. In this framework, controlling is associated with sprocket and this sprocket is associated with sprocket of front wheel by chain drive. Guiding is utilized to give the course of front wheel. The DC engine is associated with sprocket jolt at above of casing. At the point when control supply from battery to DC engine then revolving movement exchange from DC engine to the wheel. The headings are give beneath sprocket which permit to wheel turn 360 degree about vertical pivot. At that point this equivalent rotating movement is exchange to the back wheels by sprockets and chain drive course of action. So accordingly this game plan of the vehicle wheels to turn 90 degrees left and 90 degree directly from unique position, however front wheels of this vehicle pivot 360 degree by controlling, sprocket and chain drive game plan. Without moving from the spot, for example the vehicle has zero turning span

## II. LITERATURE REVIEW

### [1] Arunkumar S M, Chandan Kumar Sahu, Yubaraj G M, Jahangeer A B[18]

Proposed a system of consist of steering, chain sprocket, DC motor, wheel, bearing, iron pipe, battery and chain drive. In this system first the vehicle is stopped and wheels are then turned within the required direction with help of steering mechanism and DC motor. For the forward and backward movement of this vehicle, DC motors are used in wheel and a battery is used to provide electrical energy for the DC motor. It has turning radius nearly equivalent to negligible of length of the vehicle itself. This arrangement is to be helpful in hospitals, miniature industries and also on railway platforms.

### [2] SudipKachhia

Proposed the idea of all electric concept of vehicle is that if it becomes a reality would prove to be a lot of fun to drive in the city. The vehicle works on 8 electric motors, four motors attached uniquely to each wheels and it can rotate 360 degrees. The wheels of the car are magnetically coupled and it is controlled by magnetic fields. Hence the car is rotate fastly and effectively

### [3]. Jaishnu Moudgil

360 degree rotating car to beat the matter of parking zone. This car has zero degree turning radius of a vehicle implies the vehicle rotating about an axis passing through the axis of gravity of vehicle i.e. the vehicle turning at the similar place, where it's standing. No extra space is required to revolve the vehicle. So vehicle is to be turned within the space like to the length of the vehicle itself. during this presentation, so got idea of 360 degree wheel rotation vehicle and have plane to make 360 degree wheel rotation load carry vehicle, this vehicle is to be utilized in different area like industries, hospital, railway platform, etc.

### [4] K. Lohith

Presented a four wheel steering mechanism for a car. In four wheels steering the rear wheels revolve with the front wheels thus raising the effectiveness of the vehicle. The direction of steering the rear wheels comparative to the front wheels depends on the working circumstances. At low speed wheel movement is pronounced, in order that rear wheels are steered within the other way thereto of front wheels with the utilization of DC motor to show left and right. during this presentation, the utilization of DC motor is to rotate the wheels 90 degree left and 90 degree right from original position.

### [5] Er. Amitesh Kumar

presented zero turn four wheel steering mechanism, the a variety of functions of the steering wheel are to manage the angular motion the wheels, direction of motion of the vehicle, to supply directional stability of the vehicle while going straight ahead, to facilitate straight ahead condition of the vehicle after completing a turn, the road irregularities must be damped to the utmost possible extent. This project the utilization of steering is to rotate front wheels.

### [6] Mr. Sharad P. Mali

Presented zero turn four wheel mechanisms, in this project people have used DC motor and wheel to vehicle rotate 360 degree at a same position. So in this task, the initiative is to organize of DC motor and wheel.

## DESIGN

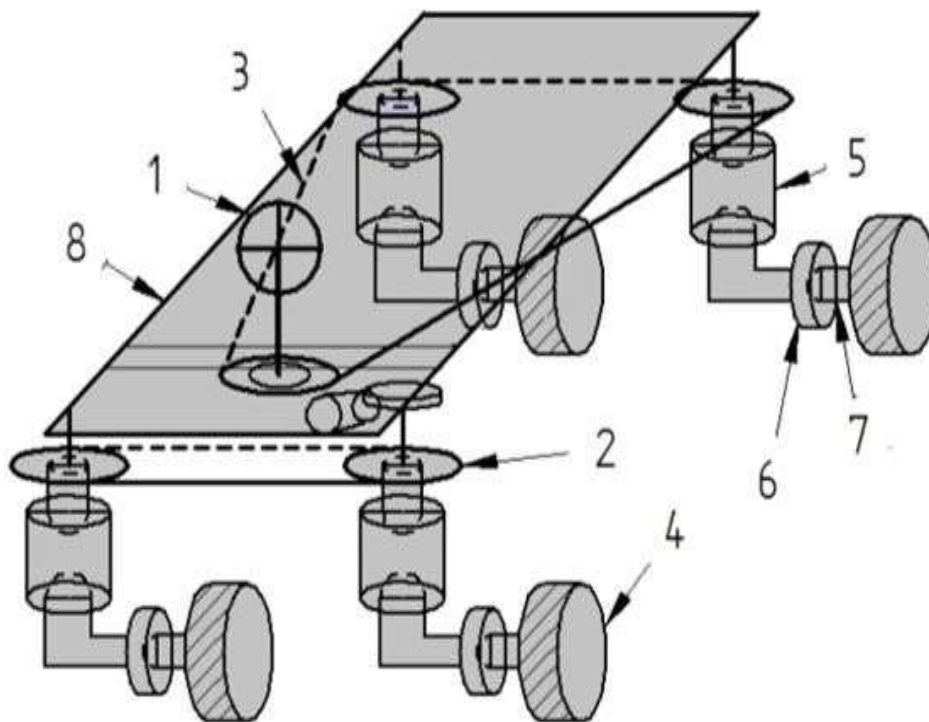

1. Steering,
2. Sprocket,
3. Chain drive,
4. Wheel,
5. Iron pipe,
6. DC motor,
7. Bolt,
8. Frame

Fig. 1 360 degree wheel rotation vehicle

### Motor calculation

#### Specification and calculation

- 60 rpm
- 12V
- 18W

$$\begin{aligned}
 \text{Torque of motor: } \tau &= P \times 60 \div 2 \times 3.14 \\
 &= 18 \times 60 \div 2 \times 3.14 \times N \\
 &= 2.866 \text{ Nm}
 \end{aligned}$$

### III. MAIN COMPONENTS

#### Steering, Sprocket, Chain drive, Wheel, Iron pipe, DC motor, Bearing, Fixed frame, Battery

**Steering:-** Steering is a element of 360 degree wheel revolving vehicle. This element is used to supply the way to the front wheels by help out sprocket and chain drive, which provides path to the front wheels clockwise or anticlockwise direction.

**Sprocket:-** A sprocket is a profiled wheel with teeth, gear-teeth, or even sprockets that work with a chain. The sprockets are utilized for the power transmission among controlling and wheel through the roller chain drive Chain sprocket is a section this

vehicle. Chain sprockets are utilized to gracefully the clockwise or anticlockwise heading to front haggie wheel through the chain drive. Sprockets are use in bikes, bikes, vehicles, followed vehicles, and other apparatus either to transmit rotating movement between two shafts where riggings are unacceptable or to grant straight movement to a track, tape and so on.

**Wheel:-** In this vehicle wheels are made of plastic material. Wheels are interface with DC engine and front wheel turn 360 degree by help of controlling, chain sprocket, chain drive and bearing game plan. The back wheels turn 90 degree left and 90 degree directly from unique situation by help of DC engine, sprocket and chain driver course of action, DC engine has given to each wheel to flexibly advance and in reverse development of wheel.

**Iron pipe:-** It is a one of significant pieces of 360 degree wheel pivot vehicle. It is made of mellow steel. Which is utilized to join bearing and DC engine of each wheel

**DC motor:** - During this vehicle one DC engine are give in each wheel to go ahead and reverse way. The detail of engine utilized is 12 V, with 60 rpm. / When power gracefully from battery to DC engine then DC engine turn clockwise way and when switch current flexibly from battery to DC engine then DC engine will anticlockwise course. Which will advance and in reverse development of car.

**Bearing:-** In this vehicle bearing is utilize simple to move wheel from one heading to other course, each bearing is associated with each wheel with the assistance of sprocket and iron pipe. Pipe .A bearing is a machine segment that obliges relative development to simply the perfect development, and lessens scouring between moving parts., and diminishes rubbing between moving parts. The plan of the bearing may, for instance, accommodate free straight development of the moving part or with the expectation of complimentary revolution around a fixed pivot; or, it might forestall a movement by controlling the vectors of typical powers that bear on the moving parts. Most heading encourage the ideal movement by limiting contact. 5.8 Fixed casing The fixed casing structures the base of the 360 degree wheel turn vehicle. This casing is made of Mellow Steel (MS). It has four wheels appended to its different sides by sprocket jolt and iron funnel.

**Battery:** - Battery is one of the significant pieces of 360 degree wheel pivot vehicle. Which is associated with DC engine by electric wire. It is store electrical vitality and gracefully to DC engine so vehicle will push ahead and reverse way. Batteries work by changing over compound vitality into electrical vitality through electrochemical release responses. Batteries are made out of at least one cells, each containing a positive anode, negative cathode, separator, and electrolyte. Cells is to be separated into two significant classes essential

#### IV. OBJECTIVES

- Designing model system
- Reduce in revolving time
- Overcome in parking difficulty
- To turn the vehicle with no leaving its centre of gravity



## V. WORKING PRINCIPLE

The base frame is manufactured as per the dimensions. At the corners of the frame the clamps are fixed with shafts mounted on them. Above the shaft the sprocket wheel setup is mounted. Totally four wheel sprocket are used in the setup. The wheel sprockets are connected using a cycle chain. Using the clamp the dc motor are mounted in the frame. The wheels are connected to the motor via the shaft. A 12v 7amp/hr battery is placed in the back of the frame. Using wire connections the motor is connected to the battery. ESP wifi board is mounted on the setup using a breadboard or card board. The relay boards are fixed in the same place. ESP wifi board is programmed by interfacing with the relay board. The interfaced electronic setup is then connected to the motor for controlling the motor setup. All the connections are made to connect to the battery. With this the setup is assembled. Now the power supply is given to all the circuits and motors. The wifi board transmits signal to the device that could pair with it. Usually a mobile device is used to connect the wifi board and display the web page that has the remote control functions. The load is loaded in the loading area. Using battery power supply the motor starts to operate. The motor operation is controlled by the ESP wifi board. There are two types of key sets for controlling the motor. The first key set controls the forward and reverse operation of the device. This is achieved by varying the power supply to the motors using the relay board. Forward movement is achieved by giving positive supply and reverse motion by reversing the polarity. The second set of keys control the directions of the setup. 360° rotation of the setup is achieved by this concept. The same principle applied above is done here also. By these processes the load is carried from one location to another without much disturbance. Due to 360° rotation of wheels the movement of the setup is far more easy than the conventional systems used. Usage of remote control for controlling the movement of the device ensures that human intervention for controlling it is reduced. Because of this human error that occur carelessly or out of consciousness is greatly reduced. Other than that the cost for movement of resources is greatly reduced and unnecessary usage of manpower is reduced. This system increases the working time of the unit. Since humans get tired after some time of hard lifting works

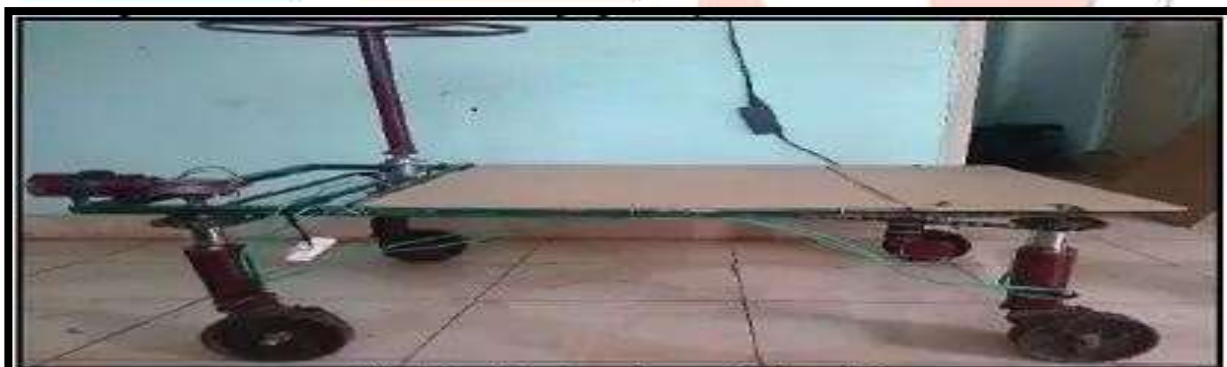

Fig. 3 the side view of assembled model

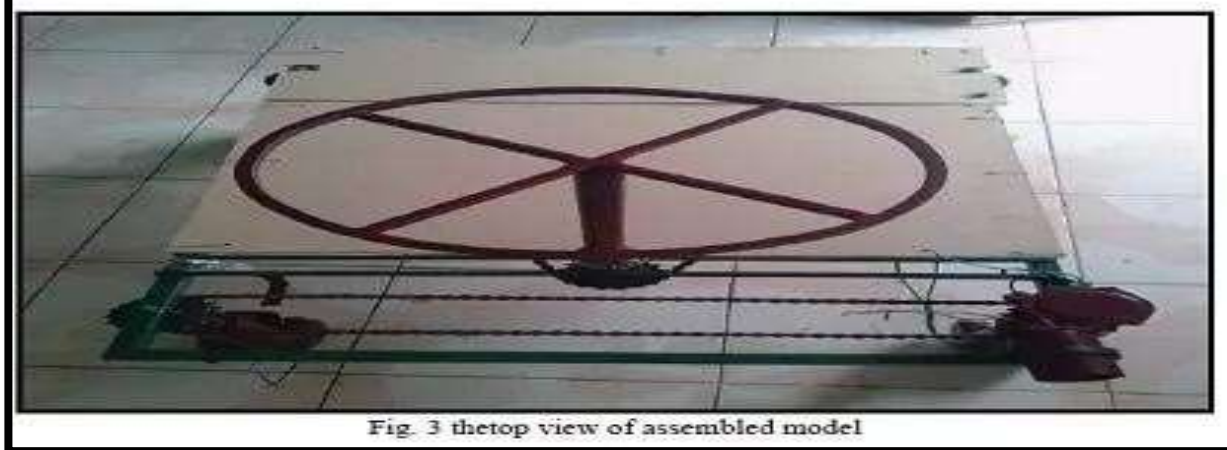

Fig. 3 the top view of assembled model

Fig. 3 and Fig. 4 show the assembled model of proposed system

## VI. CONCLUSION

A model for the proposed approach was created by acquainting controlling and DC engine with wheel turn 360 degree. This model was seen as ready to be moved effectively in tight spaces, and after production of 360 degree wheel pivot vehicle devoured less space to turn from one direction to another direction and it consumes less time to turn and this vehicle used in various area such as small industries, railway platforms and in a parking area.

## REFERENCES

- [1] Jaishnu Moudgil, Shubhankar Mengi and Mudit Chopra, 360 Degree Rotating Vehicle to Overcome the Problem of Parking Space, International Journal of Research in Mechanical Engineering and Technology, 5(2), 2015, 22-25.
- [2] Sudip kachhia, Design of 360 Degree Rotating Car, International Journal of Advance Research and Innovative Ideas In Education, 2(5), 2016, 15–16.
- [3] K. Lohith, K. Lohith, Dr. S. R. Shankapal, M. H. Monish Gowda, Development of Four Wheel, Scholars Journal of Engineering and Technology, 12(1), 2013, 52-53.
- [4] Er. Amitesh Kumar, Dr. Dinesh. N. Kamble, Zero Turn Four Wheel Steering System, International Journal of Scientific & Engineering Research, 5(12), 2014, 22-24.
- [5] Mr. Sharad P. Mali, Mr. Sagar Jadhav, Prof. D. U. Patil, Zero Turn Four Wheel Mechanism, International Engineering Research Journal, 2(2), 2016, 484-486
- [6] Neville, A., Stanton, Marsden P. (2001), From implications of automation in Vehicles, Automotive engineering, Vol. 109, No. 9, Pp. 102-106.
- [7] Rahmaan, Mohammad Ubaid Ur, et al. "360 Degree Wheel Rotation Vehicle."
- [8] Kumar, Er Amitesh, Dr Dinesh, and N. Kamble. "Zero Turn Four Wheel Steering System." International Journal of Scientific & Engineering Research 5.12
- [9] Kumar, K. Saravana. "Fabrication Of 360 Degree Rotating Wheel"
- [10] Bulatovsky, V., and L. Pedko. "Four-Wheel Steering System." (2018).