



SECURITY BASED CIRCUIT BREAKER

Under The Guidance of Mr . V . Danunjaya Naidu¹ Assistant Professor

K.S.M Jayanth babu ², K.Naveen ³, M.Pradeep kumar⁴, S.Vijay kumar ⁵

Department of Electrical & Electronics Engineering , Lendi Institute Of Engineering & Technology
Denkada (M) , Jonnada , Vizianagaram (Dt) ; Andhra Pradesh ,India

Abstract:The Security Based Circuit Breaker Is Designed To Protect The Circuit From Damage . Which Is Caused By Short Circuit Or Overload . Many Electrical Accidents Are Happened Due To Miscommunication Between The Lineman's & The Electric Substation Staff .To Avoid These Accidents ,The Project Is Designed In Which Only Authorized Person Can Operate It With The Help Of Password. The Password Based Circuit Breaker Is A System That Access Only Specified Password To Control The Circuit Breaker By Authorized Person Only. Here ,There Is Also A Provision Of Changing The Password .The System Is Fully Controlled By A Aurdino. The Code Is Dumped Into The Microcontroller, A Matrix Keypad Is Used To Enter The Password And Relay.

Keywords:Aurdino,Relay,LCDdisplay,Matrix keypad.

I. INTRODUCTION

Circuit Breakers Play A Crucial Role In Switching For The Reasons Of Both The Routine Network Operation And Protection Of Other Devices In Power Systems. To Ensure Circuit Breakers Are In Healthy Condition, Periodical Inspection And Preventive Maintenance Are Typically Performed. The Maintenance Schedules And Routines Usually Follow The Recommendation Of Circuit Breaker Vendors, Although The Recommended Schedules May Be Conservative. Security Is The Prime Concern In Our Day To Day Life. Everyone Needs To Be Secure As Much As Possible .The Electric Line Man Safety System Is Designed To Control A Circuit Breaker By Using A Password For The Safety Of Electric Man. Critical Electrical Accidents To Line Men Are On The Rise During Electric Line Repair Due To Lack Of Communication And Co-Ordination Between The Maintenance Staff And Electric Substation Staff. This Proposed System Provides A Solution That Ensures Safety Of Maintenance Staff, I.E., Line Man. The Control To Turn On Or Off The Line Will Be Maintained By The Line Man Only Because This System Has An Arrangement Such That A Password Is Required To Operate The Circuit Breaker (On/Off). The System Is Fully Controlled By The Aurdino . A Matrix Keypad Is Interfaced To The Aurdino Board To Enter The Password. The Entered Password Is Compared With The Password Generated. If The Password Entered Is Correct, Only Then The Line Can Be Turned ON/OFF. To Repair A Particular Section Of The Electric Supply Line, The Line Man Wants To Turn Off The Supply To That Line. For This He First Put A Request To The System. Then The System Responds To Him Using The LCD Display To Enter The Password. The Security Based Circuit Breaker Can Also Be Implemented In Automatic Door Locking System For Providing High Security. And Also Can Be Implemented To Control Electronic Appliances To Save The Power.

II. COMPONENTS

a)Resistor

A Resistor Is A Two Terminal Passive Electrical Component That Implements The Electrical Resistance As Circuit Element. Resistors Which Opposes The Flow Of Current Through It. This Follow The Ohms Law [$V=IR$].

b)Capacitor

Capacitor Is An Electronic Component That Store Electric Charge. The Capacitor Is Made Of 2 Close Conductors (Usually Plates) That Are Separated By A Dielectric Material. The Plates Accumulates Electric Charge When Connected To Power Source. An Ideal Capacitor Is Wholly Characterized By A Constant Capacitance C, Defined As The Ratio Of Charge $\pm Q$ On Each Conductor To The Voltage V Between Them. The Equation Is Given As $C=Q/V$.

BLOCK DIAGRAM

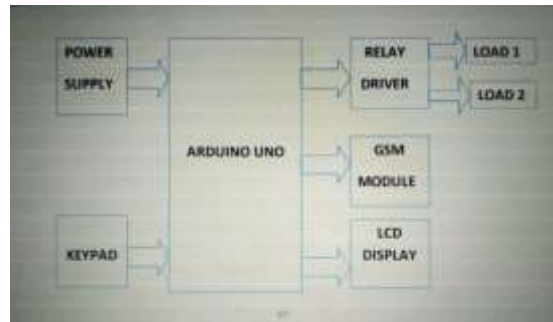

(c) Relay

A Relay Is An Electrically Operated Switch. Many Relays Use An Electromagnet To Mechanically Operate A Switch, But Other Operating Principles Are Used, Such As Solid State Relays. Relays Are Used Where It Is Necessary To Control A Circuit By A Low Power Signal (With Complete Electrical Isolation Between Control And Controlled Circuits), Or Where Several Circuits Must Be Controlled By One Signal.

d) Arduino UNO

Arduino Uno Is A Microcontroller Board Based On 8-Bit Atmega328p Microcontroller. Along With Atmega328p, It Consists Other Components Such As Crystal Oscillator, Serial Communication, Voltage Regulator, Etc. To Support The Microcontroller. Arduino Uno Has 14 Digital Input/Output Pins (Out Of Which 6 Can Be Used As PWM Outputs), 6 Analog Input Pins, A USB Connection, A Power Barrel Jack, An ICSP Header And A Reset Button.

The 14 Digital Input/Output Pins Can Be Used As Input Or Output Pins By Using Pinmode(), Digitalread() And Digitalwrite() Functions In Arduino Programming. Each Pin Operate At 5V And Can Provide Or Receive A Maximum Of 40ma Current, And Has An Internal Pull-Up Resistor Of 20-50 Kohms Which Are Disconnected By Default. Out Of These 14 Pins, Some Pins Have Specific Functions As Listed Below:

- **Serial Pins 0 (Rx) and 1 (Tx):** Rx And Tx Pins Are Used To Receive And Transmit TTL Serial Data. They Are Connected With The Corresponding Atmega328p USB To TTL Serial Chip.
- **External Interrupt Pins 2 and 3:** These Pins Can Be Configured To Trigger An Interrupt On A Low Value, A Rising Or Falling Edge, Or A Change In Value.
- **PWM Pins 3, 5, 6, 9 and 11:** These Pins Provide An 8-Bit PWM Output By Using Analogwrite() Function.
- **SPI Pins 10 (SS), 11 (MOSI), 12 (MISO) and 13 (SCK):** These Pins Are Used For SPI Communication.
- **In-built LED Pin 13:** This pin is connected with an built-in LED, when pin 13 is HIGH – LED is on and when pin 13 is LOW, its off.

Along with 14 Digital pins, there are 6 analog input pins, each of which provide 10 bits of resolution, i.e. 1024 different values. They measure from 0 to 5 volts but this limit can be increased by using AREF pin with analog Reference() function.

- Analog pin 4 (SDA) and pin 5 (SCA) also used for TWI communication using Wire library.

Arduino Uno has a couple of other pins as explained below:

- **AREF:** Used to provide reference voltage for analog inputs with analog Reference() function.
- **Reset Pin:** Making this pin LOW, resets the microcontroller.

e) Transformer

A Transformer Is An Electrical Device That Transfers Electrical Energy Between Two Or More Circuits Through Electromagnetic Induction. Electromagnetic Induction Produces An Electromotive Force Across A Conductor Which Is Exposed To Time Varying Magnetic Fields. Commonly, Transformers Are Used To Increase Or Decrease The Voltages Of Alternating Current In Electric Power Applications. A Varying Current In The Transformer's Primary Winding Creates A Varying Magnetic Flux In The Transformer Core And A Varying Magnetic Field Impinging On The Transformer's Secondary Winding. This Varying Magnetic Field At The Secondary Winding Induces A Varying Electromotive Force Or Voltage Due To Electromagnetic Induction.

f) LCD Display

The Term Liquid Crystal Is Used To Describe A Substance In A State Between Liquid Crystal Tend To And Solid But Which Exhibits The Properties Of Both. Molecules In Liquid Arrange Themselves Until They All Point In The Same Specific Direction. This Arrangement Of Molecules Enables The Medium To Flow As A Liquid. Depending On The Temperature And Particular Nature Of A Substance, Liquid Crystals Can Exist In One Of Several Distinct Phases. Liquid Crystals In A Pneumatic Phase, In Which There Is No Spatial Ordering Of The Molecules, For Example, Are Used In LCD Technology. Here This Used To Display The Password Entered By Us To ON/OFF The Circuit Breakers.

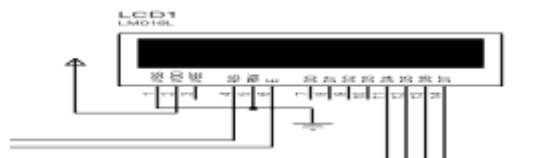

g) Relay Driver

A Relay Driver IC Is An Electro-Magnetic Switch That Will Be Used Whenever We Want To Use A Low Voltage Circuit To Switch A Light Bulb ON And OFF Which Is Connected To 220V Mains Supply. The Required Current To Run The Relay Coil Is More Than Can Be Supplied By Various Integrated Circuits Like Opamp, Etc. Relays Have Unique Properties And Are Replaced With Solid State Switches That Are Strong Than Solid-State Devices. Here ULN2003A Is Used As Relay Driver. The ULN2003A Are Monolithic High-Voltage, High-Current Darlington Transistor Arrays. Each Consists Of Seven N-P-N Darlington Pairs That Feature High-Voltage Outputs With Common Cathode Clamp Diodes For Switching Inductive Loads. The Collector Current Rating Of A Single Darlington Pair Is 500 Ma. The Darlington Pairs May Be Paralleled For Higher Current Capability.

h) Hexadecimal Keypad

HEX Keypad Is A Standard Device With 16 Keys Connected In A 4x4 Matrix, Giving The Characters 0-9, A, B, C, D, * And #. Interfacing Of Hex Key Pad To PIC 16F886 Microcontroller Is Essential While Designing Embedded System Projects Which Requires Character Or Numeric Input Or Both. For Example Projects Like Digital Code Lock, Numeric Calculator Etc. Here We Are Using This To Enter Numeric Password For Turn ON/OFF The Circuit Breaker.



III. PRINCIPLE

The Main Component In The Circuit Is PIC 16F886 Microcontroller. In This Project 4x4 Keypad Is Used To Enter The Password. The Password Which Is Entered Is Compared With The Predefined Password. If Entered Password Is Correct Then The Corresponding Electrical Line Is Turned ON Or OFF. In This Project A Separate Password Is Provided To Each Electrical Line. Activation And Deactivation Of The Line (Circuit Breaker) Is Indicated By The Load.

Circuit Diagram

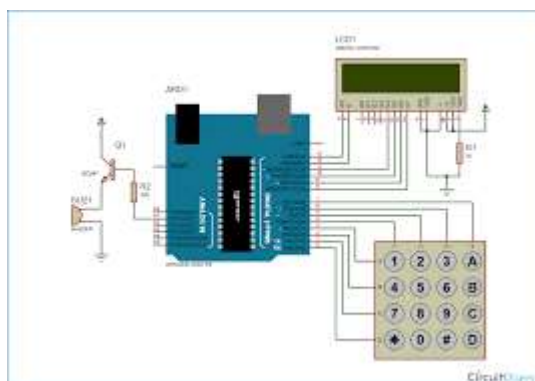

IV. OPERATION

Now Let's See How The Project Works. First, When The Power Is Turned On, The LCD Displays A Welcome Screen And Then Asks You To Enter The Password To Unlock It. In Our Case, The Password Is Fixed I.E. 123A4. By Using The Keypad, The Password Is Input And As We Type It The Password Is Seen On The LCD. If The Wrong Password Is Entered, It Will Display A Wrong Password Message And Ask You To Enter It Again. When The Correct Password Is Entered, The Main Screen Of The Circuit Breaker Is Opened. Now The Status Of The 1 Loads Connected To The Microcontroller. By The Help Of The Keypad, When You Press The Desired Button, The Output Goes To Port A And Turns On The Relay Driver IC Which In Turn Switches The Magnetic Relay And Thus The Load Turns On. By Pressing The Same Button Again, The Load Can Be Turned Off. GSM Modem Is An Important Factor In Proposed Work The 'AT' Commands Which Are Received By The Microcontroller Through Level Shifted IC Max232. As Per The Program, An Acknowledgment Is Received By SMS Being Sent Depending On Status And Acknowledgment Sent And Received. The LCD Screen Is Used To Here For Displaying Complete Operation.

V. FLOW CHART

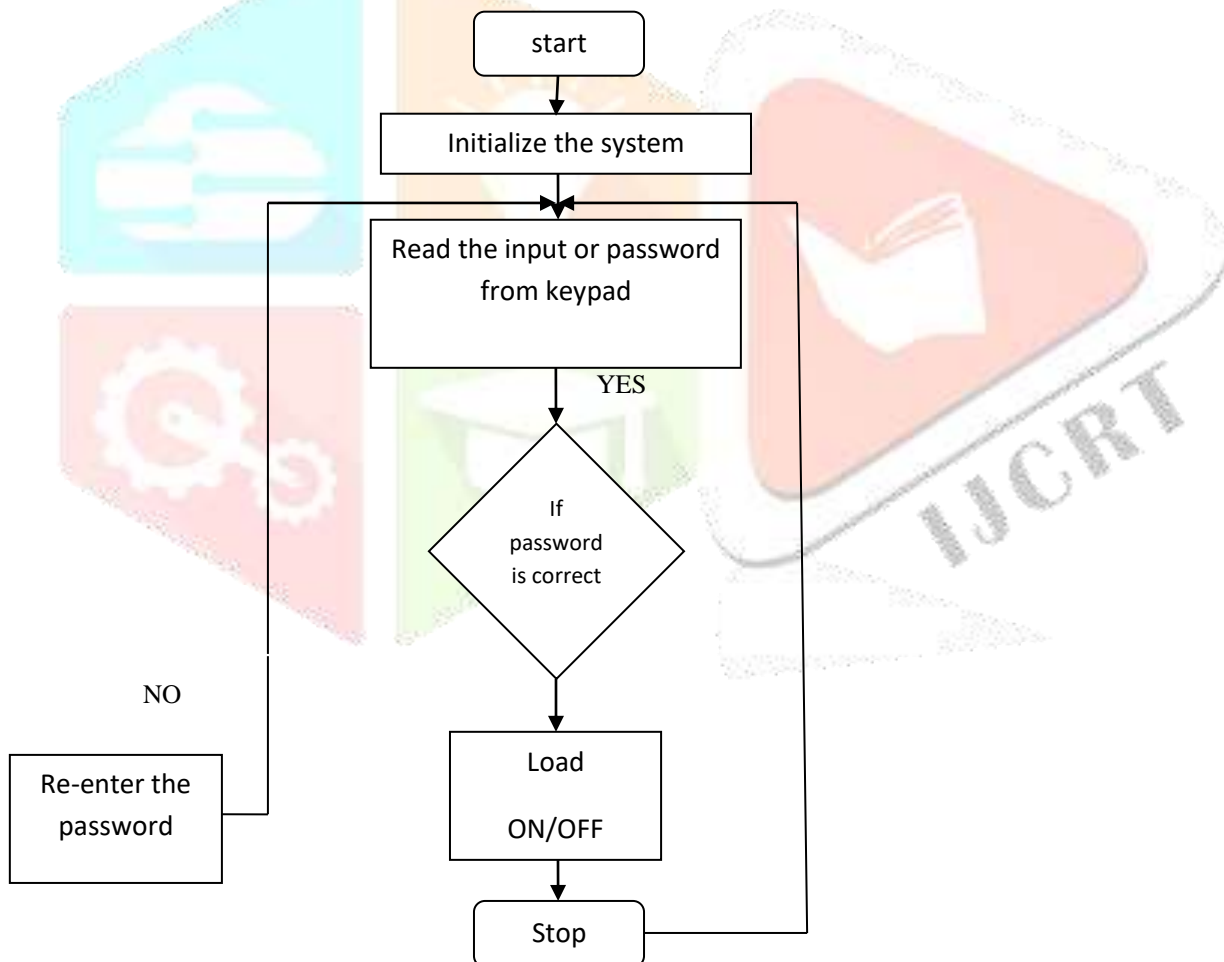

VI. ALGORITHM

- 1) Step 1: Start.
- 2) Step 2: Initialize The System
- 3) Step 3: Read The Input Or Password From Keypad.
- 4) Step 4: If Password Is Correct Then Breaker Is ON/OFF.
- 5) Step 5: If The Password Is Wrong Then Go To Step No.3..
- 6) Step 6: Stop.

VII. ADVANTAGES

- 1) Avoids Electrical Accidents To Line Man.
- 2) It Improve The Line Man Safety .
- 3) Project Is Simple And Easy .
- 4) Uses Commonly Available Components .
- 5) Most Useful To Operate In The Public Areas.

VIII. APPLICATIONS

- 1) It Is Used In Electrical Substations To Ensure Line Man Safety.
- 2) Security Based Circuit Breaker Is Used In Buildings And Houses.
- 3) Used For Saving Power In Hotels And Shopping Malls.
- 4) It Can Also Be Used As Password Based Load Control System Or Password Based Electrical Appliance Control.

IX. RESULTS AND DISCUSSIONS

This Project Can Be Used To Ensure The Safety Of The Maintenance Staff E.G. Line Man. The Line Can Be Only Turned Off/On By The Line Man. This System Provides An Arrangement Such That A Password Is Required To Operate The Circuit Breaker (ON/OFF). Line Man Can Turn Off The Supply And Comfortably Repair It, And Then Turn On The Line By Entering The Correct Password. Since It Has The Provision Of Changing The Password, Person Can Give Any Password Of His Will And Have His Work Done Safer.



Fig: CB In Close State Shown By SUCCESSFUL



Fig: CB In Open State Shown By WRONG PASSWORD

VI. CONCLUSION

This System Provides A Solution, Which Can Improve The Safety Of The Project. It Is Designed To Control A Circuit Breaker With The Help Of A Password. The Maintenance Staff E.G. Line Man's For Control To Turn ON/OFF. The Line Works With The Line Man Only This System Is Arrangement Such That A Password Is Required To Operate The Circuit Breaker (ON/OFF). Line Man Can Turn Off The Supply And Comfortably Repair It, And Return To The Substation, Then Turn On The Line By Entering The Correct Or Same Password. The System Fully Controlled By A Arduino. If The Password Entered Is Correct, Then The Line Can Be Turned (ON/OFF). Security Is Prime Concern In Our Day-To-Day Life. Everyone Wants To Be More Secure As To Be Possible. This System Provides A New Approach To A Lineman Security For Their Life. The Circuit Can Be Used Without Any Fail Of A Lineman. The Circuit Can Be Used Without Any Load Can Also Be Controlled When Required.

X. REFERENCES

- [1] M. Kezunovic, "Improving circuit breaker maintenance management tasks by applying mobile agent software technology" IEEE.
- [2] Sebin J Olickal, "Electric line man safety system with one time password based circuit breaker" IJRET, vol. 04 Special Issue: 03 Apr-2015
- [3] Narendra Khandelwal, Tanuj Manglani, Ganpat Singh, Amit Kumar, Dilip Khatri, "Automated load distribution with password protected circuit breakers" International Journal of Recent Research and Review, vol. VIII, Issue 1, March 2015.
- [4] K.B.V.S.R.Subrahmanyam, "Electric lineman protection using user changeable password based circuit breaker" IJCESR, vol. 2, ISSUE-5, 2015.
- [5] Michael faxa, "Application of disconnecting circuit breakers, p.11" Retrieved 9 July 2012.
- [6] Muhammad Ali Mazidi and Janice Gillispie Mazidi, "The microcontroller and embedded systems", Person Education.
- [7] 16F886 Data sheets.
- [8] Vincent Del Toro, "Electrical engineering fundamentals".
- [9] "Disconnecting circuit breakers, buyer's and application guide, p.10" Retrieved 15 September 2014.
- [10] Thomas L. Floyd, "Electronic Devices", Vol. I, 6 th edition, 2003, Pearson Education, ppZ