

# SMART PHONE BASED ACCESS CONTROL SYSTEM

<sup>1</sup>N.Chenchaiah, <sup>2</sup>M.Rekha, <sup>3</sup>U.Chandu <sup>4</sup>Sk.Abdul Kareem <sup>5</sup>N.Anil

<sup>1</sup>Associate Professor, <sup>2,3,4,5</sup>B.Tech Final Year Students

Department of EEE

Narayana Engineering College Gudur, Andhra Pradesh, India.

### ABSTRACT

This undertaking presents a plan and model usage of Home Automation that utilizes WiFi (Short for Wireless Fidelity) innovation as a system interfacing parts. The controlling gadget for Automation in the venture is a NODE MCU. The information sent from Smartphone with Blynk Application over Wi-Fi will be received by Wi-Fi module ESP8266 connected to NODE MCU. NODE MCU reads the data the switching activity of electrical gadgets connected to it through relays. Users and administration can locally or remotely control framework code. Dissimilar to the majority of accessible home automation system in the proposed system is adaptable that one server can many equipment interface modules as long as it exists on WiFi network coverage. System having wide range home automation.

Keywords- IoT, Blynk app, Relay , Node MCU.

### 1.Introduction

A home automation system is an implies that enable users to control electrical appliances various kinds. Home automation Depends on wired correspondence with the remote advancements, for example Wi-Fi, cloud arranges in the recent past, system are utilized each day and all over the place. Wireless system can be extraordinary help for automation system. The task goes for planning designing an remote operation utilizing ordinary web server and Wi-Fi technology. The devices or gadgets can be switched ON/OFF and relay can be read using personal smart phone through Wi-Fi with range of 40-300 feet. Wi-Fi had initial speed of 1mbps to 3mbps. Wi-Fi transmits data in the frequency band of 2.4GHz.

#### Internet of things using Home Automation

The Internet of Things (IoT) is the system of physical gadgets, vehicles, home appliances and other different things installed with hardware, programming, sensors, actuators, and network which enables these items to connect exchange data. IoT enables articles to be detected or controlled remotely across over existing system. Coordination of the physical world into PC based systems, and bringing about enhanced effectiveness, accuracy, decreased human intervention. Which additionally envelops advances, for smart grids ,virtual power plants, smart homes, savvy urban communities. Field activity operation that help firefighters in such rescue tasks. The device gather information with assistance of different existing independently flow the information between different devices.

### 2.Design & Description:-

This project presents the design of low cost smart home automation utilizing the IoT (Internet of Things). IoT is the between systems administration of physical gadgets, vehicles and different things installed with hardware, programming, sensors, actuators, and system availability that enable these objects to gather information.

In This project IoT technology is utilized to control the home apparatuses remotely over the internet. The process module used is a NODE MCU development board. The project also aims to Blynk control interface to the user to control appliances. The objective of the task is to build up a home automation system that gives the user control over all remotely controllable from a central host PC, the Internet and also remotely accessed via Android Mobile based application. Android controlled smart home automation should be have capacity to control the home appliances remotely with successfully and effectively.

Controlling Home appliances via Application to build up an application that incorporates the features of switches application . Switch mode can be utilized to control the switches of home appliances. Controlled by any device equipped for Wi-Fi (Android, iOS, PC) to make the home automation flexible in control, any gadget fit for Wi-Fi network will ready to control the home appliances from remote area.

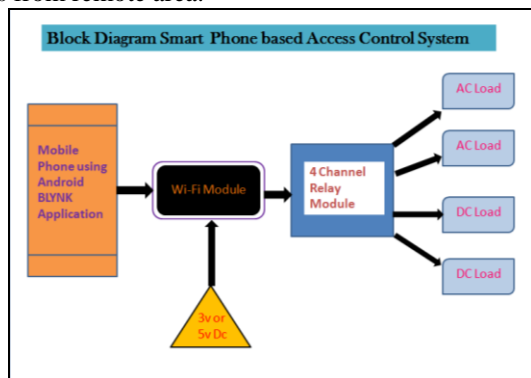

Fig:1 Block Diagram

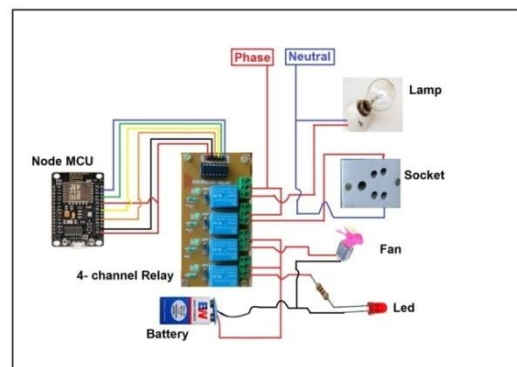

Fig:2 Schematic Circuit Diagram

### 3.Hardware components:-

**NodeMCU/ ESP-12E Wi-Fi Module:-**

The ESP8266 Wi-Fi Module is an independent SOC with integrated TCP/IP protocol stack that can give any microcontroller access to your Wi-Fi network. The ESP8266 is able to do either facilitating an application or off loading all Wi-Fi organizing capacities from another application processor. The connector offered access to the pins utilized for serial correspondence, in particular RX and TX, and also four control pins ,GPIO0,GPIO2,CH\_PD and RST (reset) along VCC and GND. NodeMCU was made shortly after the ESP8266 came turned out.

Pins of NodeMCU give access to the GPIO(General Purpose Input/ Output) and for creating purposes stick mapping table from API documentation Should be reference.

NODEMCU 1.0V2 PIN TABLE				Disconn.	Test		
IO	GPIO	NODEMCU USE		BooTh	DigitalRead	I2c	DigitalWrite
0	D3	solo output		Disconn.	no	no	ok
1	D10	UART se usi USB non si può usare					
2	D4	solo output		Disconn.	no	no	ok
3	D9	UART se usi USB non si può usare					
4	D2	normalmente usati per I2C		OK	OK		ok
5	D1	normalmente usati per I2C		OK	OK		ok
6		N/A		N/A	N/A	N/A	N/A
7		N/A		N/A	N/A	N/A	N/A
8		N/A		N/A	N/A	N/A	N/A
9	SD2	no		no	no	no	no
10	SD3	OK		OK	OK		ok
11		N/A		N/A	N/A	N/A	N/A
12	D6	OK		OK	OK		ok
13	D7	OK		OK	OK		ok
14	D5	OK		OK	OK		ok
15	D8	OK		OK	OK		ok
16	D0	no interrupt		Disconn.	ok	no	ok
17	A0	analog input-output		OK	N/A		OK

Table: 1 GPIO Pins

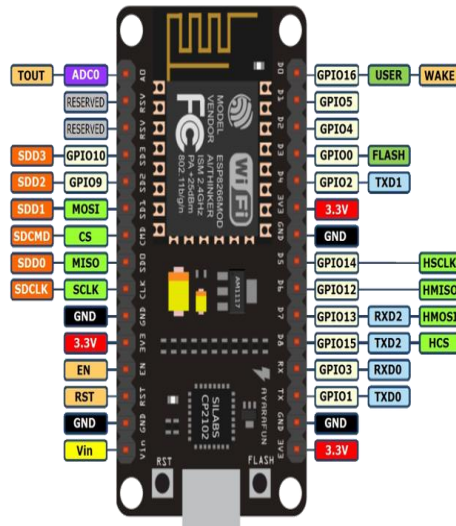

Fig: 3 Pins of NodeMCU

**RELAY:-**

A Relay is an electrically operated switch. A basic electromagnetic transfer comprises of a curl of wire wrapped around a delicate iron center (a solenoid), an iron yoke which gives a low reluctance way to attractive motion, a movable iron armature, and at least one arrangements of contacts (two contacts in the relay picture). The armature is pivoted to the burden and mechanically connected to at least one arrangements of moving contacts, The armature held set up by a spring so the relay is de-energized air gap in attractive circuit. In this condition, one of the two arrangements of contacts in the relay picture is close and other side is open.



Fig:4 Four Channel Relay

**4.Software Tools**

**STEPS TO SETUP ARDUINO IDE FOR NODE MCU ESP8266**

Stage1:Installing Arduino IDE Software

<http://www.arduino.cc/en/main/software>

To begin with you should have your arduino board (you can pick your board) USB cable.

Stage2: Download Arduino IDE Software.

You can download different version of IDE from the download page official site.

Stage3: Launch Arduino IDE

After your arduino IDE software is downloaded inside you can discover the application.exe .Double tap the symbol.

Stage4: open your first task once product begins, you have two alternatives:

- 1.Create project
- 2. Open existing project.

Stage 5: Preferences

Open the File and tap on the perferances

URL [http://arduino.esp8266.com/stable/package\\_esp8266com\\_index.json](http://arduino.esp8266.com/stable/package_esp8266com_index.json)

Stage 6:Adding ESP8266 Board Manager

Step 7: Selecting Board

Presently open the devices in that select board “Node MCU 1.0 (ESP-12E Module)” tap on the board manager.

Stage 8: ESP8266 Board package

Stage 9: Connecting ESP8266 to the PC

Stage 10: Uploading the program to ESP8266 Module.

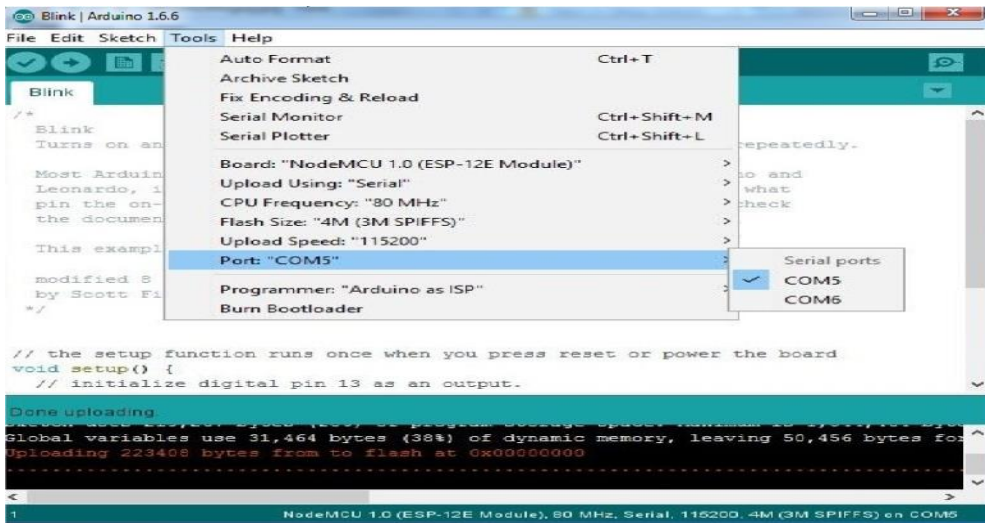

Fig: 5 Uploading the program to NODE MCU

5.Blynk APIs:

Blynk API (Application Programming Interface) was intended for the internet of things. It can control equipment remotely, it can show sensor information, it can store information, Visualize it and do numerous other cool things.

There are three segments in this stage:

- ❖ Blynk App- permits to make interfaces for your utilizing different gadgets we give.
- ❖ Blynk Server- in charge of the considerable number of interchanges between the smart phone & equipment. cloud or run your private its an a open-source could server such that huge number of devices can be propelled.
- ❖ Blynk Libraries- for all the prevalent equipment stages-empower corresponding with server & process all the approaching and outcoming commands.

Each time you press a Button in the Blynk application, the message goes to space the Blynk Cloud, where it mystically discovers its way to your equipment.

It authorize approve developers to switch mode utilizes the radio catches that are utilized to control the home appliances. The radio catch sends the status of the switch storage on blynk cloud storage by utilizing a similar innovation it can be utilized to construct a demand. The request can be sent to server to process and execute.

This system makes smart home automation simple control and access with no additional gadgets.

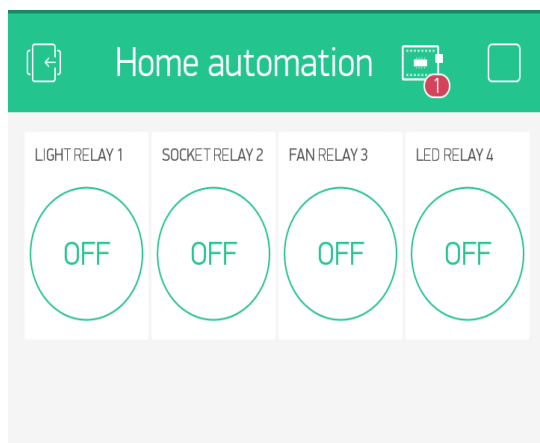

Fig:6 All switches are OFF condition

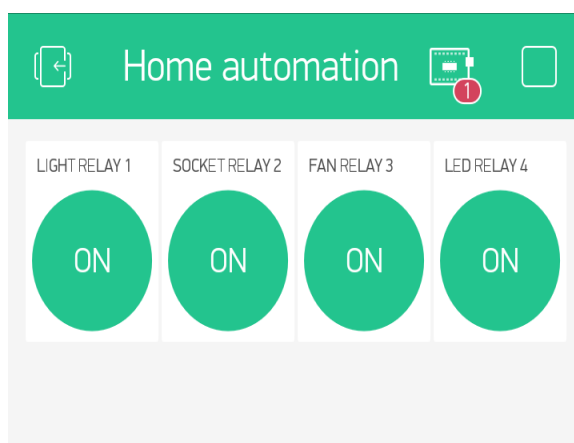

Fig:7 All switches are ON condition

Blynk App Control



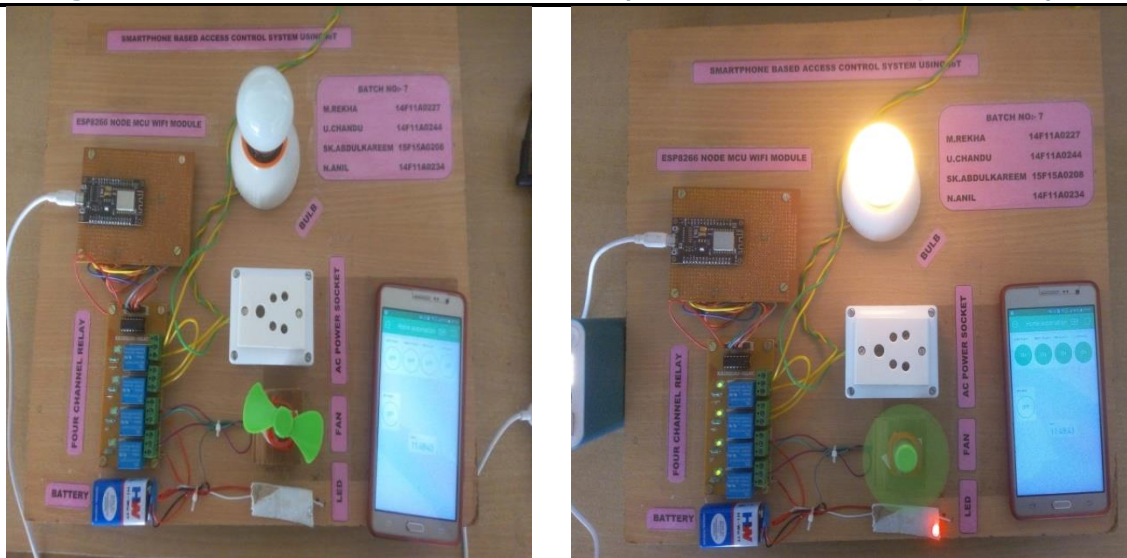

Fig:8 Hardware implementation of Node MCU & Blynk Application

## 6.Applications

- ❖ Home automation
- ❖ Industrial wireless control
- ❖ IP Cameras
- ❖ Security ID tags
- ❖ Smart power plugs

## 7.Conclusion:

In general large android application are extremely basic and easy to use enabling the client to understand its functionalities in next to little time. This system however principally intended to decrease human exertion, will be of much significance to old matured individuals and physically handicapped people. It will empower them to control their home gadgets without experiencing much weight or worry of moving about. It discovers application in a wide region. Versatility of the task would be impressively simpler as the device can be utilized as a part of each building using electrical appliances and devices.

## 8.Reference:-

- [1] Ming Yan and Hao Shi “SMART LIVING USING BLUETOOTH BASED ANDROID SMARTPHONE” International Journal of Wireless & Mobile Networks (IJWMN) Vol. 5, No. 1, February 2013 DOI : 10.5121/ijwmn.2013.5105 65
- [2] Folea, S. ;Autom. Dept., Tech. Univ. of Cluj-Napoca, Cluj-Napoca, Romania ;Bordencea, D. ; Hotea, C. ; Valean, H – “SMART HOME AUTOMATION SYSTEM USING WI-FI LOW POWER DEVICES” Published in: Automation Quality and Testing Robotics (AQTR), 2012 IEEE International Conference on Date of Conference: 24- 27 May 2012 Page(s): 569 – 574 Print ISBN:978-1- 4673-0701-7 ; INSPEC Accession Number: 12853582 Conference Location :Cluj-Napoca ; DOI:10.1109/AQTR.2012.6237775 ; Publisher: IEEE.
- [3] Chakradhar, B., Krishnaveni, S., and Naresh , D. 2013. “Bluetooth Based Home Automation and Security System Using ARM9”, International Journal of Engineering Trends and Technology (IJETT) , Vol. 4 Issue 9, Pg 4053-4058 [ 8 ] Obaid, T. et al. 2014. “ZIGBEE BASED VOICE CONTROLLED WIRELESS SMART HOME SYSTEM”, International Journal of Wireless & Mobile Networks (IJWMN), Vol. 6, No. 1, Pg. 47-5
- [4] Mohamed Abd El-Latif Mowad, Ahmed Fathy, Ahmed Hafez “SMART HOME AUTOMATED CONTROL SYSTEM USING ANDROID APPLICATION AND MICROCONTROLLER” International Journal of Scientific & Engineering Research, Volume 5, Issue 5, May2014 ISSN 2229- 5518.
- [5] Arduino Uno Projects: <http://arduino.cc/en/Main/arduinoBoardUno>.
- [6] <http://www.electronica60norte.com/mwfls/pdf/newBluetooth.pdf>
- [7] Node Mcu <https://en.wikipedia.org/wiki/NodeMCU>
- [8] BLYNK Server <https://community.blynk.cc/>
- [9] <https://www.hackster.io/abhijitbrain/iot-home-automation-node-mcu-blynk-12cc34>
- [10] <https://www.hackster.io/skulter/alexa-nodemcu-smart-home-automation-with-your-own-hub-1a229f>