

IOT Based Health Monitoring System

D.Rajesh Reddy¹ B.Harika² A.Ranganadh³ G.Lakshmanudu⁴ K.Kalyani⁵

1 - Asst.Professor, EEE Department, NECG, AP.

2,3,4,5 - IV.B.Tech Students , EEE Department, NECG, AP

Abstract— In this project, a secure and efficient authentication and authorization architecture for IOT-based healthcare is developed. Security and privacy of patients' medical data are crucial for the acceptance and ubiquitous use of IOT in healthcare. Secure authentication and authorization of a remote healthcare professional is the main focus of this project. Our main idea is to suggest the fact that how and why the understanding of the health monitoring system by using the IOT tools, which are recommended to acquire the specifications and use the data that is acquired from the IOT tools is important. This Health monitoring system also tells the patient with possible cautious strides to be penetrated by them. This structure proposes the patient with restorative personality and next walk to be taken after if there ought to be an event of fundamental condition. 'The HEALTH MONITORING SYSTEM' structure is valued for the particular viewpoints and the decisions are made on the data which are obtained from the source are relied upon to do the survey.

Keywords — *Arduino, IOT, Medicinal services, Sensors and pulse rate of the heart.*

INTRODUCTION

The advancement of web is colossal and moreover it is extended to interfacing things through web. All devices are related with each other with various splendid progressions to make far and wide inescapable framework is known as the Internet of Things (IOT). For example, IOT creates immense measure of the information, prompts new time of data. Information produced by the IOT gadgets are utilized for examination and basic leadership prepare. The employments of information of things can be amassed into the space as (i) Transport and coordination's (ii) Medicinal services (iii) Keen environment (iv). Individual and social [1]. The parts of IOT in every one of the above spaces are surprisingly wide.

Transport and coordination's vehicle recognizable proof, vehicle to vehicle correspondence, activity correspondence and so forth are the real progressions in the field of IOT. These days Government concentrates on making keen urban areas to utilize all the rising advancements and building up the country to contend universally. Each and each individual is encompassed by keen gadgets, which is utilized to interface with the 3G/4G arrange, informal communities and other savvy advancements. The quality of IOT and its effect on each individual's every day life, for example, excitement, work,.The key empowering component of IOT is in restorative and human services. IOT gadgets are utilized to gather, screen, and assess what's more and provides a better suggestion to the patient along with the data. As per Borgia [2], the entrance of IOT gadgets in medicinal what's more, human services (i). Remote checking medicinal values (ii). Diagnosis of patients (iii). Medicinal machinery following (iv). Privacy to get inside condition (v). Keen doctor's facility administrations (vi). Amusement administrations.

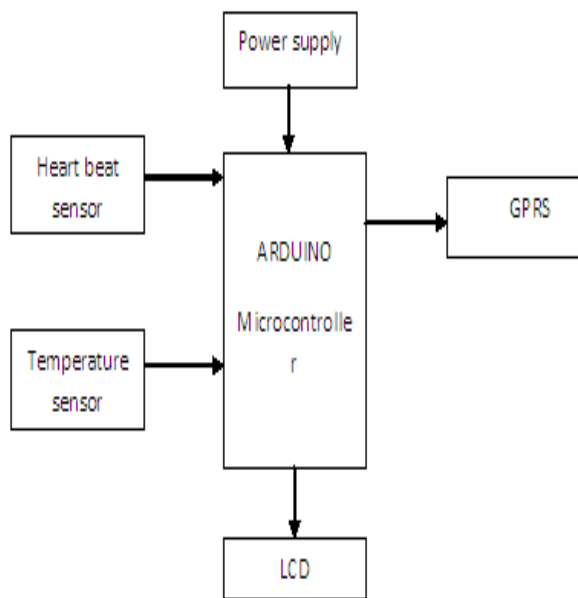

Figure 1. Health monitoring system

The remote observing of a patient by the specialist is as yet a testing undertaking. To break down the wellbeing state of the understanding, different therapeutic values are required from the patients. Gathering the values and imparting to the specialist through the correct systems administration channel is another testing assignment. The rest in this paper sorted out as takes after. Of segment 2, work related to IOT gadgets of medicinal services is given. The engineering of HEALTH MONITORING SYSTEM is clarified in segment 3. The method for executing the HEALTH MONITORING SYSTEM is examined in area 4.

ARDUINO UNO

The Arduino microcontroller is an easy to use yet powerful single board computer that has gained considerable traction in the hobby and professional market. The Arduino is open-source, which means hardware is reasonably priced and development software is free. This guide is for students in ME 2011, or students anywhere who are confronting the Arduino for the first time. For advanced Arduino users, prowl the web; there are lots of resources. This is what the Arduino board looks like. patients in light of the investigation is outlined in area 5. The completion of the work initiated framework and the conceivable future works are shown in area 6. Information is utilized to examine the sickness and danger happening to the patients. Franca examined advancements in new era of frameworks were improvement of nonstop observing elements involved in monitoring patients what's more, change in work processes, efficiency of medicinal individual. Likewise underlined the different remote advances and the benefits of utilizing those advances for quicker correspondence [5]



Figure .2 Arduino microcontroller

Securing in this module is to worry in IOT gadgets administration. Four distinguished necessities were (i). Security confirmation and approval, (ii).Security bootstrap of items in sending of information, (iii).Secure information of IOT, (iv). Security in accessing information by the approved people. Mohammed talked about main conveyance is needed in security of E-wellbeing applications. Administration it permits caught information which is to be moved into security place. IOT organization in the medicinal services need greater secure since information of the patients is sensitive and it ought should not be abused of any terrible components in general public. Debiao and Sherali talked about the secure prerequisites and validation plans for RFID in view of elliptic Curve Cryptography (ECC).

Information detected and sent to remote gadgets can be seen on the neighborhood framework which necessities to bolster getting information of multiple configurations, is valuable in making constant apps is to be refreshed to versatile utilization by the specialist and in addition the client (patient or the guardian). Boyi et. al. exhibited IOT related framework in offering help the crisis medicinal administrations by showing a way in which IOT information is gathered to incorporate inter-operability Long et. al. examined fundamental necessities in point interest for product of human services he invented engineering of social insurance and IOT. The patient had to take basic parameters like ECG (electro cardio Cristina et.gram), oxygen levels in blood, breath rate, and body temperature and so on.In extent to wellbeing connected issues in absence of legitimate arrangement of medicinal services in screening of patients is done in nonattendance by the specialist, patients confront significant issues patients may lose life in some basic situations, to avoid the issues HMS (HEALTH MONITORING SYSTEM) is introduced to screen and assess performance of each patient by specialist even though in nonappearance of specialist in clinic or close. Regularity of a pattern can be calculated with the difference of the consecutive occurrences of the particular pattern, the maximum difference value is considered as regularity of a pattern. \

ARCHITECTURE

The health monitoring system consists of 3; they are gathering stage, sending stage, use stage. Body Area Network (BAN) is developed in gathering information required from patient. Modules that are used to

analyze the malady differ starting with 1 infection then onto the next. Consequently everything is detected by the isolate IOT gadgets on association with client. Every one of the gadgets associated to the patient's body is called as BAN at information accumulation stage. Pulse module, heart rate screen, temperature and so on are the fundamental gadgets used to gather the pulse, heartbeat, body temperature of patient. Information gathered in the accumulation stage to be conveyed to specialist in order to assess values for conclusion. human being is 98.6°F (37°C). It is measured by temperature sensor and sent to checking framework by a remote gadget

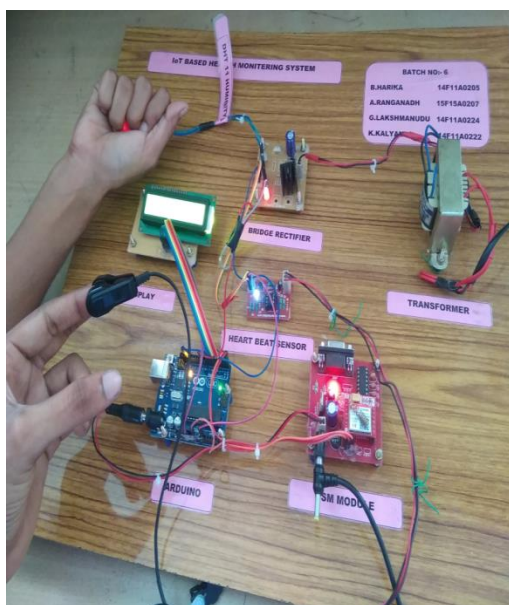

Fig. 3: Architecture of Project

Temp more than 98.6°F (37°C) is to be considered as noteworthy. Pulse sensor associated to 8051 microcontroller is utilized in screening pulse of a client is appeared. The gathered information has to be refreshed in the health monitoring system. The specialists, patients monitors (approved to see), patients is able to see points of interest utilizing the versatile app in web modules. A portable app is given to specialists by patient id and secret word. Specialists are able to see every one of the subtle elements related with their patients. Data, for example, body temperature.

GSM MODULE

A GSM modem is a device which can be either a mobile phone or a modem device which can be used to make a computer or any other processor communicate over a network. A GSM modem requires a SIM card to be operated and operates over a network range subscribed by the network operator. It can be connected to a computer through serial, USB or Bluetooth connection.

A GSM modem can also be a standard GSM mobile phone with the appropriate cable and software driver to connect to a serial port or USB port on your computer. GSM modem is usually preferable to a GSM mobile phone. The GSM modem has wide range of applications in transaction terminals, supply chain management, security applications, weather stations and GPRS mode remote data logging.



Figure: 4. GSM Modem

ANALYSIS OF RESULTS

This framework receipts the information by the IOT gadgets for at regular intervals and refreshed into the database associated to a server. A specialist will be able to see the patients' wellbeing disorder at regular intervals. The framework gets the blood weight information to compare with table 1 assess clients report and know status. Also the beat degree analyzed in table 2 .normal infection sprays over Sample Temperature Data Of 10 Patients for two days 98.6°F (37°C) is measured as anomalous infection. Information gathered by clients sensors and its assessment the request, demonstrated the watched information is refreshed effectively.



Figure: 5. experimental LCD display



Figure: 6. Result on LCD display

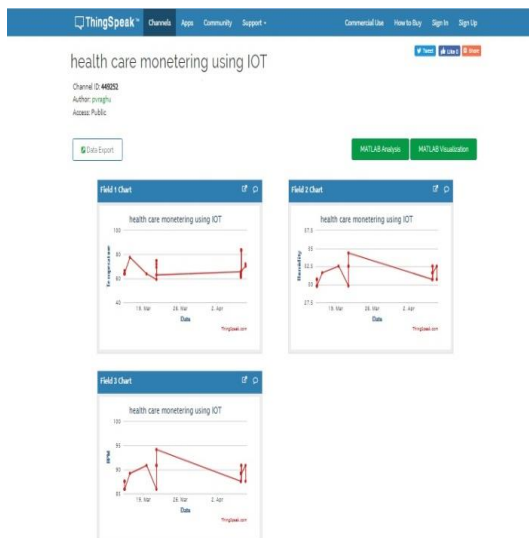

Figure :7. Result On Serial Monitor

An effective health monitoring system is produced to screen the avant- garde position of client independent nearness of the specialist. The system assembles the information like heat, circulatory strain and pulse rate of the

The framework is assessed tentatively and gathered the example information of ten patients to check the status of the patients. The specialist can screen the advance of patients' wellbeing once in a while to prompt them about their wellbeing the framework can be stretched out by adding more components to the portable application like connecting the emergency vehicle administrations, driving specialist's rundown and their specialties, healing facilities and their exceptional offices and so on., doctors can make mindfulness about ailments and their side effects through the portable request. From the assessment and the outcome gotten from examination the framework is improved for clients and the specialist to enhance their patient's restorative assessment.

CONCLUSIONS

This proposed system, it is concluded that IoT based healthcare monitoring system is emerging as a significant element of healthcare services. In proposed system a mobile physiological monitoring system is presented, which is able to continuously monitor the patients' heartbeat, blood pressure and other critical parameters in the hospital or home. The system is able to carry out a long-term monitoring on patients' condition and is equipped with an emergency rescue mechanism using mail. Prompt them about their wellbeing the framework can be stretched out by adding more components to the portable application like connecting the emergency vehicle administrations, driving specialist's rundown and their specialties, healing facilities and their exceptional offices and so on., doctors can make mindfulness about ailments and their side effects through the portable request. From the assessment and the outcome gotten from examination the framework is improved for clients and the specialist to enhance their patient's restorative assessment.

REFERENCES

- [1] Ya-lin Miao, Xiang-lin Miao, Zheng-Zhong Bian, Yong-jie Zhang Xi'an Jiaotong University, Xi'an 710049, China "Design and application of Embedded System based on ARM7 LPC2104 Processor in Telemedicine," Proceedings of the 2005 IEEE.
- [2] Ying-Wen Bai, Chien-Yung Cheng, Chou-Lin Lu and Yung-Song Huang, "Design and Implementation of an Embedded Remote ECG Measurement System," IMTC 2005 - Instrumentation and Measurement Technology Conference Ottawa, Canada 17-19 May 2005.
- [3] Nivedita Daimiwal, Asmita Wakankar, Dipali Ramdasi and Mrunal Chandratreya "Microcontroller Based ECG and Blood Pressure Simulator," J. Instrum. Soc. India 37(4) 243-248.
- [4] Mohamed Fezari, Mounir Bousbia-Salah, and Mouldi Bedda "Microcontroller Based Heart Rate Monitor," The International Arab Journal of Information Technology, Vol. 5, No. 4, October 2008.
- [5] M. Chaitanya Suman, K. Prathyusha "Wireless ECG System Based on ARM LPC 2103 Processor," IJECT Vol. 3, Issue 1, Jan. - March 2012, ISSN: 2230-7109 (Online) | ISSN: 2230-9543 (Print).
- [6] M. B. I. Reaz "Tele-Health ECG Monitoring System: A Low Cost Approach," International Islamic University Malaysia, Kuala Lumpur, Malaysia.

