

SOLAR PHOTOVOLTAIC POWER DRIVEN PMDC MOTOR

¹ Narne Sindhuja, ²Meriyala Subramanyam

¹PG student, ²Assistant Professor

¹Electrical and Electronics Engineering,

¹Sai Tirumala Nvr Engineering College, Jonnalagadda, India

Abstract:

At present, the major contribution of electricity generated using fossil fuels, the major problems with this availability of fuels and causes more pollution. So there is necessity of non-extinguish and pollution free energy source for the power generation. Solar is one eminent and abundant in nature. Photovoltaic (PV) power generation directly converts solar light into direct current (DC) power. The power obtained from PV used dc applications. In order to maximise the utilization of PV panel maximum power point tracking (MPPT) technique is used. Perturb and observer (P&O), method is one the simple and easiest method to extract maximum power from PV panel. The MPPT operation can be achieve using Cuk converter, because it provides continuous input current, able to step up and step down DC input voltage, produce ripple free current and no requirement of inversion of the output voltage. One of the major applications of PV is electrical vehicles (EV), where the motor used for EV applications is permanent magnet DC (PMDC) motor due to easy control, higher efficiency, low maintenance and less size as compared to regular DC motors.

Keywords:

Permanent magnet direct current (PMDC) motor, PV, Cuk converter, electric vehicle (EV), perturb and observer (P&O), MPPT.

I. Introduction:

Around 40% of energy for the world is obtained by electrical energy. To meet this demand, most of the developed countries are depended on conventional power plants like nuclear, thermal and hydro power plants etc. With rapid consumption of fossil fuel such as coal, oil and gas, and the resulting energy crisis and growing environmental pollution. Country like India is actively developing new, clean, economical, safe and reliable renewable energy such as photovoltaic power generation. Solar PV systems are so popular in isolated and remote areas. Photovoltaic (PV) systems are combined with solar modules, power-conditioning devices and load [1], [2].

Solar powered electricity generation uses photovoltaic panels. All photovoltaic cells are combined to form PV panels, which converts light from solar into electricity. The electricity thus generated from the PV cells is being used in many industrial as well as domestic purposes. Nowadays PV panels are being more commonly used to drive water pumps for overhead tank and for irrigation purposes. Unlike conventional diesel machine or any electrical pumps, solar panel/array of solar panels is used for powering solar pump. Solar pumps can operate with both AC and DC power. During unavailable or unreliable condition of power supply, these solar pumps/solar motors are gaining popularity everywhere around the world. In such places, Pumps running on solar energy are economically viable in comparison to grid or running the pump on diesel. Minimum maintenance cost, harmonious with nature, long life and easy installation at remote places are the main advantages of PV system. As per the market research, usage of solar energy is predicted at 15.3% annual growth for the industry in the next three years. Even more optimistic is that solar cell cost will continue to drop by 10% every year till 2020 [3]. In this paper, a solar module is interfaced with a PMDC drive along with maximum power point tracking technique using Cuk converter. From the available PV power, the drive characteristics are obtained.

II. Proposed system configuration :

Fig.1 shows block diagram of PV driven PMDC motor, depending upon the input irradiation and temperature PV panel convert the light energy into direct current. Inorder to extract maximum power from the PV panel, the PV output voltage and current feed to Perturb and Observe MPPT to get optimum duty cycle which is utilised by Cuk converter which gives required power to drive the PMDC motor.

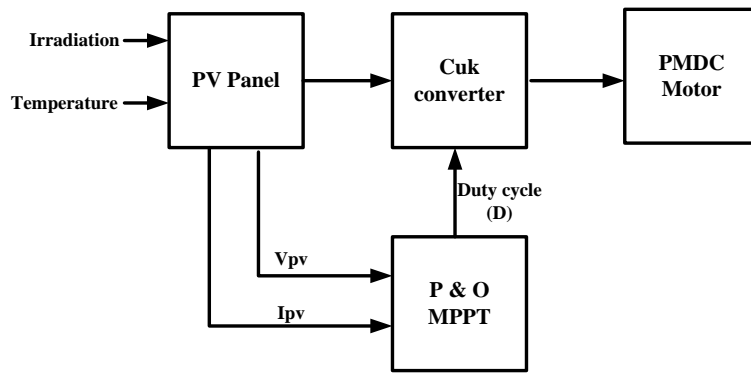

Fig.1 PV driven PMDC motor

i. PV Array Modelling:

Fig.5. shows the equivalent circuit of the ideal PV cell. The basic equation from the theory of semiconductors [4] that mathematically describes the $I-V$ characteristic of the ideal PV cell is

$$I = I_{pv} - I_d \tag{1}$$

$$I = I_{pv} - I_0 \left[\exp\left(\frac{qV}{akT}\right) - 1 \right] \tag{2}$$

where I_{pv} , I_d , I_0 , q , k , T and a are the current generated by the incident light that is directly proportional to the Sun irradiation, shockley diode equation, reverse saturation or leakage current of the diode, electron charge ($1.60217646 \times 10^{-19}$ C), boltzmann constant ($1.3806503 \times 10^{-23}$ J/K), temperature of the $p-n$ junction in kelvins and ideality constant of diode, respectively.

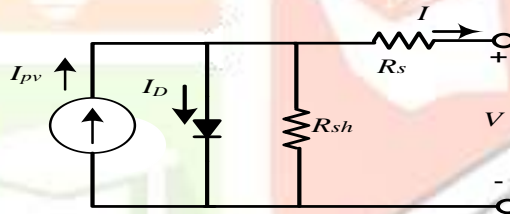

Fig.2. Equivalent circuit of PV cell

Practical arrays are composed of several connected PV cells and the observation of the characteristics at the terminals of the PV array requires the inclusion of additional parameters to the basic equation

$$I = I_{pv} - I_0 \left[\exp\left(\frac{V + R_s I}{V_t a}\right) - 1 \right] - \frac{V + R_s I}{R_{sh}} \tag{3}$$

Where I_{pv} and I_0 are the photovoltaic (PV) and saturation currents, respectively, and $V_t = N_s k T / q$ is the thermal voltage of the array with N_s cells connected in series. The cells are connected in parallel increase the current and cells connected in series provide greater output voltages. If the array is composed of N_p parallel connections of cells the PV and saturation currents may be expressed as $I_{pv} = I_{pv,cell} N_p$, $I_0 = I_{0,cell} N_p$. R_s and R_{sh} are the equivalent series and parallel resistance of the array respectively.

Here, R_s basically depends on the contact resistance of the metal base with the p semiconductor layer, resistances of the p and n bodies, contact resistance of the n layer with the top metal grid, and resistance of the grid. The R_{sh} resistance exists mainly due to the leakage current of the $p-n$ junction and depends on the fabrication method of the PV cell. The internal characteristics of the device (R_s , R_{sh}) and on external influences such as irradiation level and temperature.

The assumption $I_{sc} \approx I_{pv}$ is generally used in the modeling of PV devices because in practical devices the series resistance is low and the parallel resistance is high. The light-generated current of the PV cell depends linearly on the solar irradiation and is influenced by the temperature according to the following equation:

$$I_{pv} = (I_{pv,n} + K_1 \Delta T) \frac{G}{G_n} \tag{4}$$

where $I_{pv,n}$ (in amperes) is the light-generated current at the nominal condition (usually 25°C and 1000 W/m^2), $\Delta T = T - T_n$ (T and T_n being the actual and nominal temperatures in Kelvins, respectively), G is the irradiation on the device surface in watts/m^2 , and G_n is the nominal irradiation.

The diode saturation current I_0 in terms of temperature expressed by

$$I_0 = I_{0,n} \left(\frac{T_n}{T}\right)^3 \exp\left[\frac{qE_g}{ak} \left(\frac{1}{T_n} - \frac{1}{T}\right)\right] \tag{5}$$

Where E_g is the bandgap energy of the semiconductor ($E_g = 1.12$ eV for the polycrystalline Si at 25°C). Moreover, the nominal saturation current ($I_{0,n}$) can be expressed as:

$$I_{0,n} = \frac{I_{sc,n}}{\exp(V_{oc,n} / aV_{t,n}) - 1} \tag{6}$$

with $V_{t,n}$ being the thermal voltage of N_s series-connected cells at the nominal temperature T_n .

ii. P and O MPPT algorithm:

As the solar input irradiation is a variable nature and its unable to utilise all the available power from the PV panel. Which can be achieved by using a maximum power point tracking (MPPT) algorithm. Here perturb and observe (P&O) MPPT algorithm is used to track the maximum power from the PV panel as it is simple in implementation and low cost. The algorithm for the P and O [5] is shown in Fig.3.

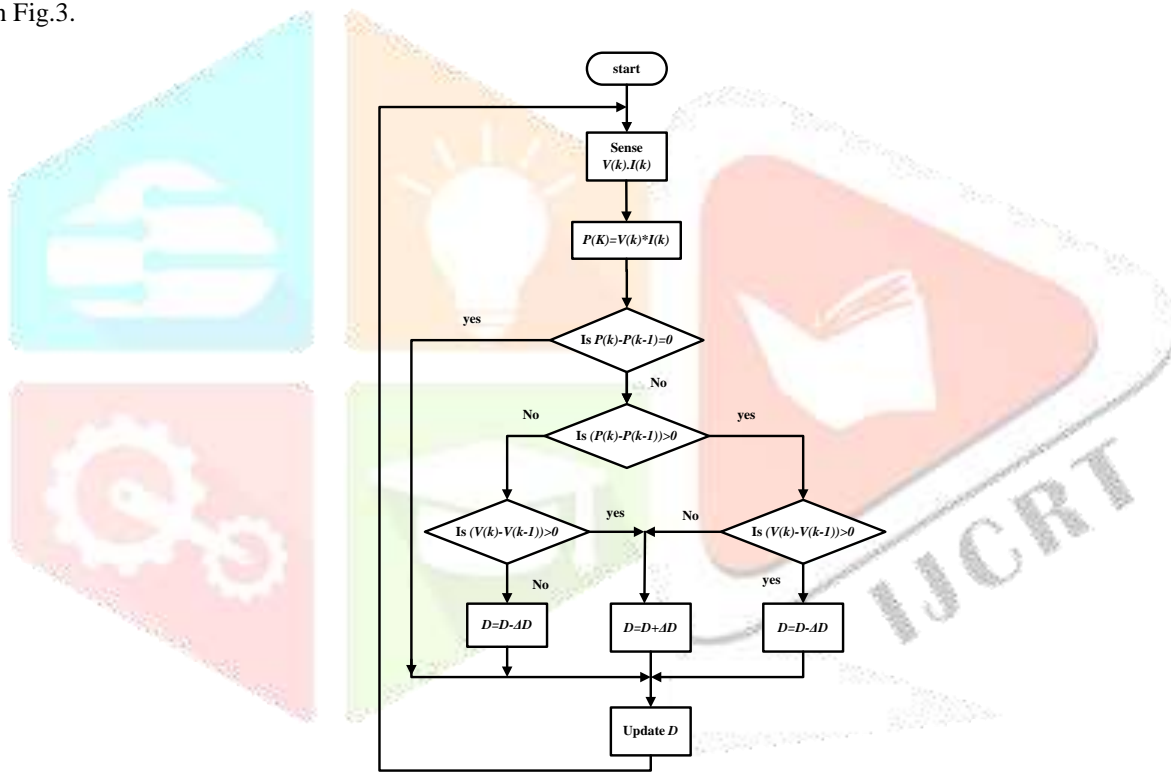

Fig.3 P and O MPPT method

iii. Cuk converter:

This is also similar to buck-boost converter and the output voltage obtained at the output terminal is inverted. Even though the Cuk converter is costlier, it has the merits such as continuous input and output current as well as the output voltage lower or higher than input voltage[6]. The Cuk converter consists of two inductors, two capacitors, switch and a diode as shown in Fig.4.

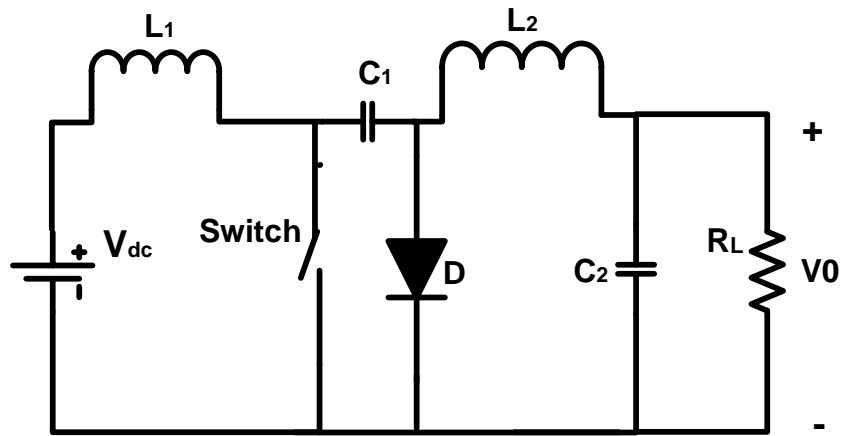

Fig.4 Cuk converter

The capacitor C is used to transfer energy and is connected alternately to the input and to the output of the converter via the commutation of the transistor and the diode. The two inductors L₁ and L₂ are used to convert respectively the input voltage source (V_{dc}) and the output voltage source (V_o) into current sources. At a short time scale an inductor can be considered as a current source as it maintains a constant current. This conversion is necessary because if the capacitor were connected directly to the voltage source, the current would be limited only by the parasitic resistance, resulting in high energy loss. Charging a capacitor with a current source (the inductor) prevents resistive current limiting and its associated energy loss.

The following the expressions associated with the Cuk converter which are used for designing it properly:

The voltage the capacitor is $V_{c1} = \frac{V_{dc}}{1-D}$ (7)

The output voltage given by the Cuk converter $V_0 = \frac{-DV_{dc}}{1-D}$ (8)

The current flowing through the inductor is negative of the load current is given by

$$I_{L2} = -I_0 = -\frac{V_0}{R_L} = \frac{-DV_{dc}}{(1-D)R_L} \text{ and} \tag{9}$$

$$I_{L1} = \frac{-D^2V_{dc}}{(1-D)^2R_L} \tag{10}$$

Table1: Cuk converter specifications

Input voltage (V _{dc})	15-24 Volts
Switching frequency (f _s)	15-25 kHz

iv. PMDC Motor:

Permanent magnet dc machine modelling is done based on the following equations [7]:

$$V = I_a R_a + L_a \frac{dI_a}{dt} + k_m \omega_m \tag{11}$$

$$T_e = k_m I_a \tag{12}$$

$$J \frac{d\omega}{dt} = T_e - T_L - B_m \omega_m \tag{13}$$

Where V, I_a, R_a, L_a, k_m, ω_m, T_e, T_L, B_m and J are DC input voltage, armature current, armature resistance, armature inductance, torque constant, rated motor speed, electromagnetic torque, damping coefficient and inertia constant respectively.

Table2: PMDC motor specifications

PMDC motor	Specification
Input voltage V	24 V
Maximum current I_m	3.1 A
Maximum power P_{max}	60 W
Rated speed N_{rated}	4000 rpm

III. Simulation Results:

The performance characteristics of 60 W solar panel is simulated and their corresponding voltage versus current (V-I), power versus voltage (P-V) characteristics

a) Photovoltaic characteristics

Modelling of PV panel described according to equations (1)-(6), in Fig.5 and Fig.6 the *I-V* and *P-V* curves, at a single temperature and irradiation shown.

An MSX 60 solar panel having following data sheet ratings at STC as shown in Table.2.

Table3: Data sheet for solar panel MSX60

S.No	Specification	Value
1.	Open circuit voltage	21 V
2.	Short circuit current	3.74 A
3.	Maximum voltage MPP	17.1 V
4.	Maximum current at MPP	3.5 A
5.	Maximum power	59.4 W

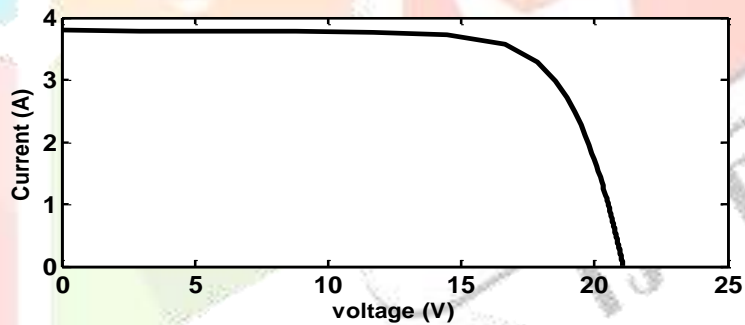

Fig.5. V-I characteristics of solar panel

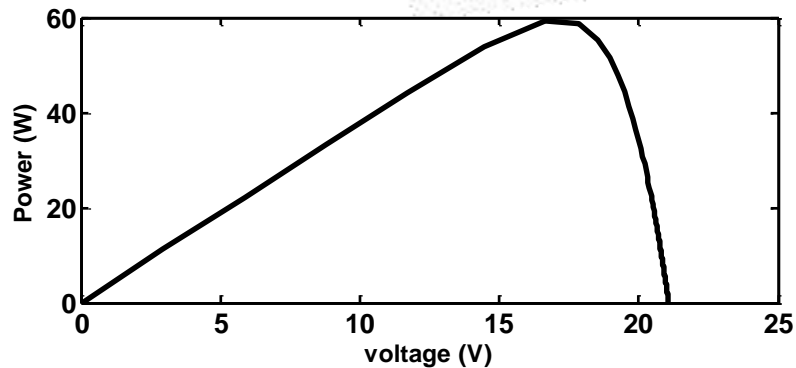

Fig.6. P-V characteristics of solar panel

The variation of the output power of the solar array depends upon the irradiance and temperature the performance characteristics of the PV array under various irradiances by keeping all the parameter constant as shown in Fig.7. The effect of temperature variation on the PV characteristics are as shown in Fig.8.

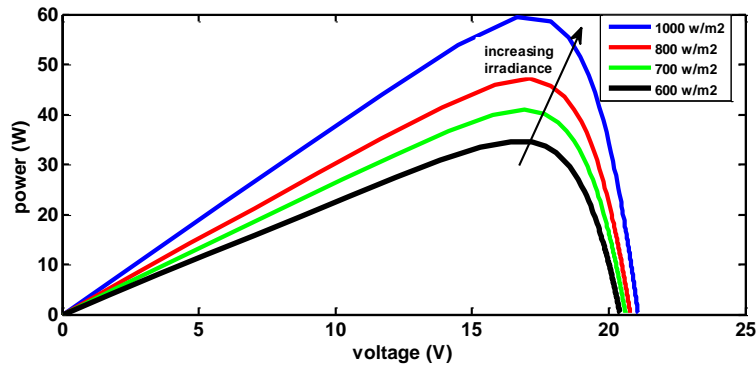

Fig.7. Variation of irradiance on P-V characteristics of the solar panel

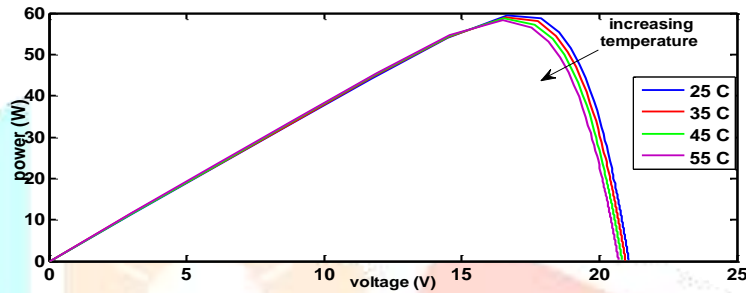

Fig.8. Variation of temperature on P-V characteristics of PV array

b) PV driven PMDC motor:

The Simulink block diagram shows PV driven PMDC motor, which is coupled through a Cuk converter as shown in Fig.9

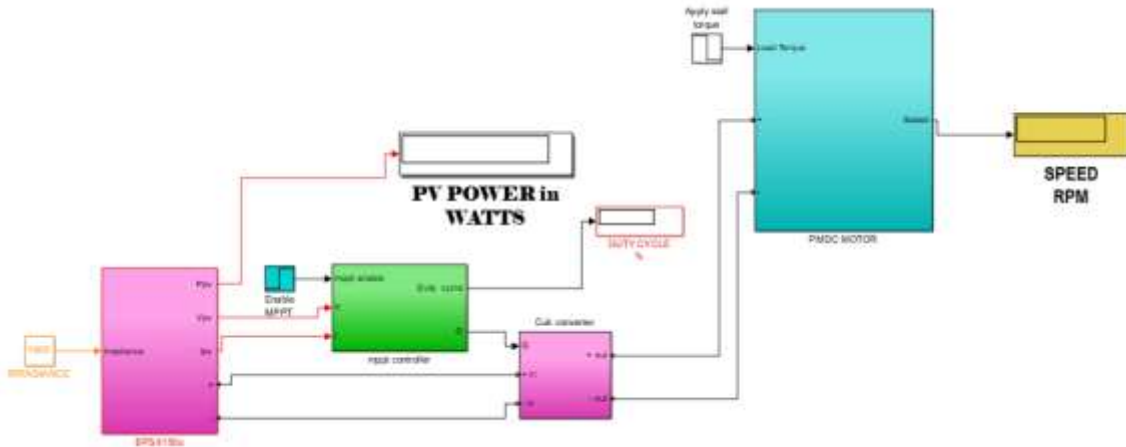

Fig.9 MATLAB Simulink diagram of PV driven PMDC Motor

The output current and speed of the motor is obtained at a irradiation of 1000 W/m² and 25 °C as shown in Fig.10 and Fig. 11 taking current and speed as y-axis coordinates and time as x-coordinates. At the starting due to transients armature draws more current later it reaches to steady state and takes the full load current of 3.1 A and speed of the motor reaches rated speed at 4000 rpm.

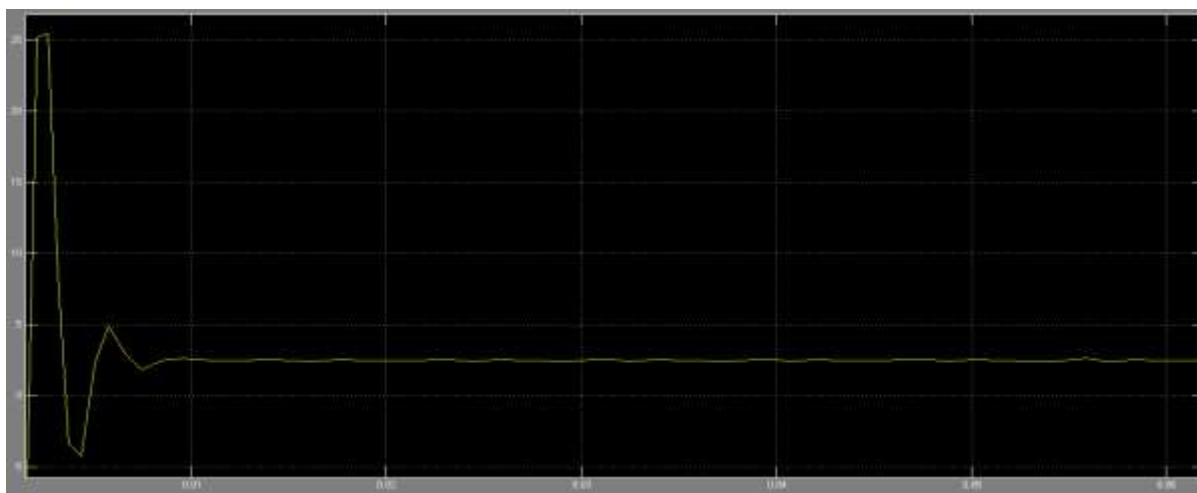

Fig.10 Armature current of the PMDC motor

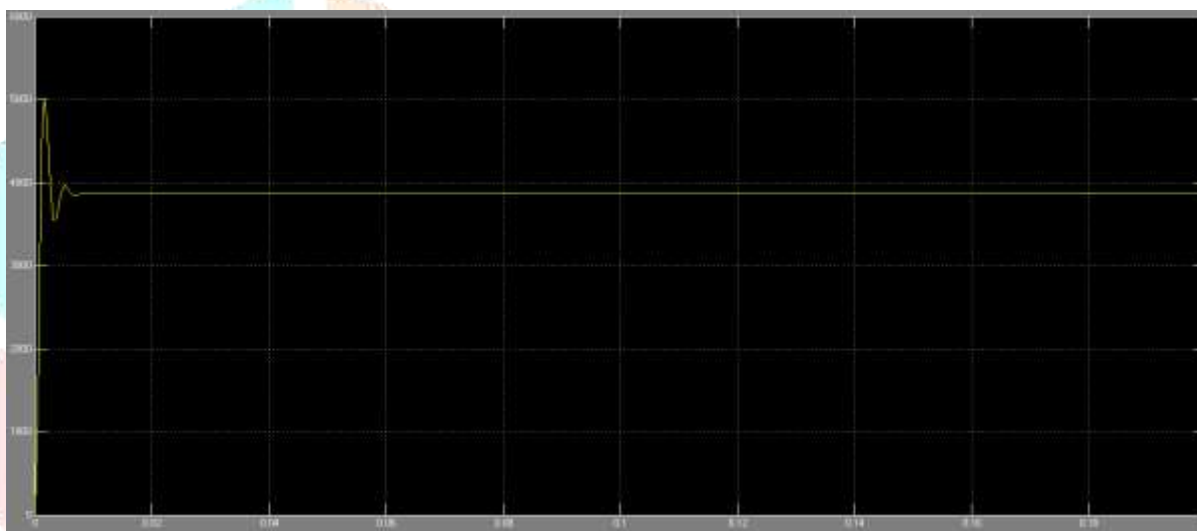

Fig.11 speed (in rpm) of the PMDC motor

IV. Conclusions:

Solar power is one of the finest renewable energy sources as the use of it in drive applications make more prominent. Here PV driven PMDC motor application by designing required PV power to drive permanent magnet DC motor and also maximum power is extracted from the PV panel using perturb and observer MPPT as well as Cuk converter. From the results it is clear that the PV system is providing required voltage, current and speed of the PMDC motor.

References:

- [1] World Energy Council, "World Energy Issue Monitor 2017," p. 156, 2017.
- [2] "World Energy Assessment: Energy and the Challenge of Sustainability | UNDP." [Online]. Available: http://www.undp.org/content/undp/en/home/librarypage/environmentenergy/sustainable_energy/world_energy_assessmentenergyandthechallengeofsustainability.html. [Accessed: 19-Apr-2018].
- [3] World Energy Council, "World Energy Resources 2016," *World Energy Resour. 2016*, pp. 1–33, 2016.
- [4] M. Villalva, J. Gazoli, and E. Filho, "Comprehensive Approach to Modeling and Simulation of Photovoltaic Arrays," *IEEE Trans. Power Electron.*, vol. 24, no. 5, pp. 1198–1208, 2009.
- [5] T. H. Kwan and X. Wu, "High performance P&O based lock-on mechanism MPPT algorithm with smooth tracking," *Sol. Energy*, vol. 155, pp. 816–828, Oct. 2017.
- [6] M. H. Rashid, *Power Electronics Handbook*.
- [7] T. Khan Nizami, A. Chakravarty, and C. Mahanta, "A Fast Learning Neuro Adaptive Control of Buck Converter driven PMDC Motor: Design, Analysis and Validation," *IFAC-PapersOnLine*, vol. 50, no. 1, pp. 37–42, Jul. 2017.