

Gesture Based Motor Control MEMS Accelerometer

Ms.Abinaya.V¹ Ms.Jerlinrosary.M¹

Ms.Savitha.R¹, Ms.Shilpa.D¹

Mrs.Gomathi.M², Dr.Kannan.M³

¹ UG Scholar, Department of ECE, Kathir College of Engineering.

² Assistant Professor, Department of ECE, Kathir College of Engineering.

³ Head of the Department, Department of ECE, Kathir College of Engineering.

Abstract: This paper presents a model for gesture controlled user interface (GCUI), and identifies trends in technology, application and usability. It present an integrated approach is real time detection, gesture based data which control vehicle movement and manipulation on gesture of the user using hand movements in all three direction. A three axis accelerometer is adaption. With each passing day the gap between machines and human is being reduced with the introduction of new technology is easy the standard of living. Its having future scope of advanced robotic arms that are designed like the human hand itself can easily controlled using hand gesture only and also make it more efficient different software were used. It also having proposed utility in field of construction, medical science, hazardous waste disposal etc.

Keywords: MEMS, Gesture, Accelerometer, motor driver, cc2500, PIC16F877A

1. Introduction

In the existing system, human hand movements are sensed by the robot through sensors and it follow the same. As the person moves their hand, the accelerometer also moves accordingly sensor displaces in two axis and this sensor senses the parameter according to the position of hand.

In this system, a gesture driven robotic vehicle is developed, in which the vehicle movements and manipulations are done by the accelerometer and it is processed by software namely, embedded software and the parameters are sent to microcontroller and encoder circuit.

It is further transmitted (transmitter section) by cc2500. In the receiver section, the cc2500 receiver holds down the received parameters and process with microprocessor and gives those parameters to the robotic vehicle so that it act accordingly to the gesture.

2. Literature Survey

Using Teach box for Programming and control of a robot is a tiresome and time-consuming task that requires technical knowledge. Therefore, the approach is to have new and more intuitive ways

for programming & control of robot. In the robotics field, several research efforts have been made to create user-friendly teach pendants, implementing user interfaces such as color touch screens, a 3D joystick. But, these techniques are not efficient to control the robot as they do not give accurate results and provide slow response time. In the past years the manufacturers of robot have made efforts for creating "Human Machine Interfacing Device. Using gesture recognition concept, it is possible to move a robot accordingly. Accelerometers are the main technologies used for human machine interaction which offer very reasonable motion sensitivity in different applications. Motion technology makes easy for humans to interact interventions caused by the drawbacks of mechanical devices. Accelerometer-based gesture recognition has become increasingly popular over the last decade compared to vision based technique. The factors that make it an effective tool to detect and recognize the human gestures are its low-moderate cost & relative small size of the accelerometers

3. Proposed System Overview:

Accelerometer:- An Accelerometer is a kind of sensor which gives an analog data while moving in X,Y,Z direction or may be X,Y direction only depends on the type of the sensor. In accelerometer there is some arrow showing if we tilt these sensors in that direction then the data at that corresponding pin will change in the analog form.

Accelerometer-based gesture recognition has become increasingly popular over the last decade compared to vision based technique. The factors that make it an effective tool to detect and recognize the human gestures are its low-moderate cost & relative small size of the accelerometers



Fig.1.Accelerometer

Transmitter Module(TX):- In transmitter module PIC16F8771 is used and is easily available in the market at nominal cost. RC7 is connected to the cc2500 transmitter or we can say that encoded data. Then next pin is 5V Vcc .The next pin is GND that is connected to the ground terminal.

Receiver Module (RX):- The receiver module will receive the data which is transferred by the gesture device. It is also working as similar to the transmitter module- Connect the +vcc pin to the 5volt terminal. Connect the ground pin to the ground terminal .The data pin is then connected to the cc2500. So that we can get the decoded 4 bit data.

Decoder (CC2500):- CC2500 converts that serial data into parallel which is received by the receiver module. The input data is decoded when there is no error or unmatched codes are found. A valid transmission is indicated by a high signal at VT pin that is pin no1.



Fig.2. CC2500 Transceiver

Microcontroller:- The PIC16F877A features 256 bytes of EEPROM data memory, self programming, an ICD, 2 Comparators, 8 channels of 10-bit Analog-to-Digital (A/D) converter, 2 capture/compare/PWM functions, the synchronous serial port can be configured as either 3-wire Serial Peripheral Interface (SPI™) or the 2-wire Inter-Integrated Circuit (I²C™) bus and a Universal Asynchronous Receiver Transmitter (USART). All of these features make it ideal for more advanced level A/D applications in automotive, industrial, appliances and consumer applications.



Fig.3.PIC16F877A

LCD 16*2:

16×2 Character LCD is a very basic LCD module which is commonly used in electronics projects and products. The interface between this LCD and Microcontroller can be 8 bit or 4 bit and the difference between them is in how the data or commands are send to LCD. In the 8 bit mode, 8 bit data and commands are send through the data lines DB0 – DB7 and data strobe is given through E input of the LCD. But 4 bit mode uses only 4 data lines. In this 8 bit data and commands are splitted into 2 parts (4 bits each) and are sent sequentially through data lines DB4 – DB7 with its own data strobe through E input. The idea of 4 bit communication is introduced to save pins of a microcontroller. The speed difference is only minimal. As LCDs are slow speed devices, the tiny

speed difference between these modes is not significant. Just remember that microcontroller is operating at high speed in the range of MHz.

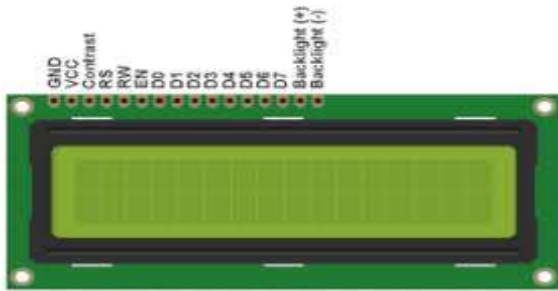

Fig.4. 16*2 Lcd display

4. System implementation

4.1 Methodology for hand motion recognition

The handheld controller is a 3D rigid body that can be rotated about the three orthogonal axes. Yaw, pitch and roll are referred to as rotation. These rotation takes place as X-axis, Y-axis, Z-axis. Any orientation can be achieved by the composing those three elemental rotation. The hand gesture is the easy and natural way of communication. Hand gesture recognition has the various advantages of able to communicate with the Technology through basic sign language.

The gesture will able to reduce the use of most prominent hardware devices which are used to control the activities of computer. In this, all of the planned hand motions for robot control are simple gestures, each of which contains only one of the three elemental rotations. Gestures composed of more than one elemental rotation are also applied for such kind of application.

4.2 Methodology for communication signal

Transmitter Module

The transmitter module is a small PCB ie, printed circuit board sub-assembly capable of transmitting a radio wave and modulating that wave to carry data. Transmitter modules are usually implemented alongside a micro controller which will provide data to the module which is transmitted. Gesture controlled robot moves according to hand movement as we place transmitter in our

hand. When we tilt hand in front side, robot start to moving forward and continues moving forward until next command is given.

Fig.5. Block Diagram of Transmitter module

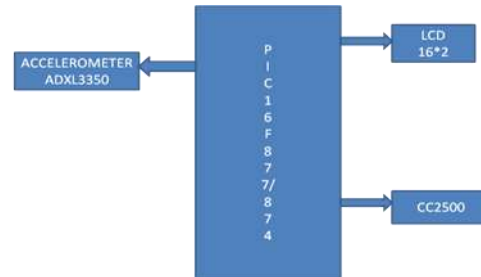

Receiver Module:

The Receiver module Cc2500 is 2.4GHz . High sensitivity (-104 dBm at 2.4 kBaud, 1% packet error rate). Low current consumption (13.3 mA in RX, 250 kBaud, input well above sensitivity limit)..Excellent receiver selectivity and blocking performance. The RF transceiver is integrated with a highly configurable baseband modem.

In receiver module According to received data we drive robot by using two DC motor in forward, reverse, left, right and stop direction. Radio receiver which receives the transmitted coded from the remote place these codes are converted to digital format and output is available to the pin no 2 of the ic2 master microcontroller; this is the pin of inbuilt art of the microcontroller.

We Based on the input codes master will give command to slave microcontroller and robot will behave as follows,

- Moves in forward direction.
- Moves in reverse direction.
- Speed controls in both the direction.
- It can even turn left or right while moving forward or in reverse direction.
- In case of bump, moves reverse turn left or right and wait for the next instruction.
- On the spot left or right turn to pass through the narrow space.

- We have also added head light, back light and turning lights to left a right.

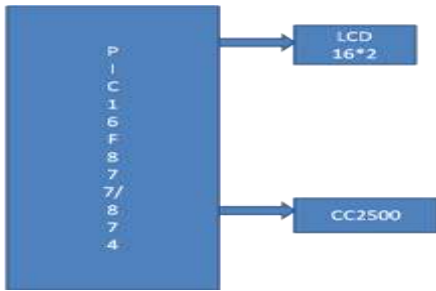

Fig.6. Block diagram of Receiver module

4.3 Methodology for motion control

This project controls a remote motor through CC2500 transceiver. The ordinary 2.4GHZ CC2500 modules are used in this project. PIC16F877A microcontroller is used in this project. This motor can perform their operations without direct human guidance.

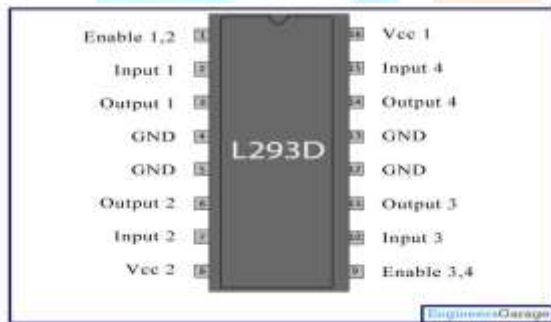

Fig.7.L293D Motor driver IC

5. Voltage Controlled Devices

Optotriac:

Optotriac are used to control the high power circuits today by low voltage and low current circuits.

Devices that are used in control of high voltage or high power equipment need to have good electrical insulation between their high voltage output and low voltage input.

Triac BT136

- Direct triggering from low power drivers and logic Ic's.
- High blocking voltage capability.

- Triggering in all four quadrants.
- Low holding current for low current loads and lowest EMI at commutation.
- Sensitive gate.
- It is universally useful in motor control.

6.Schematic diagram

Transmitter

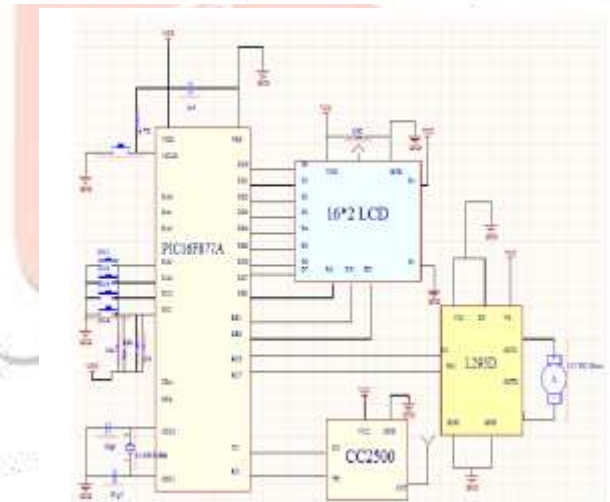
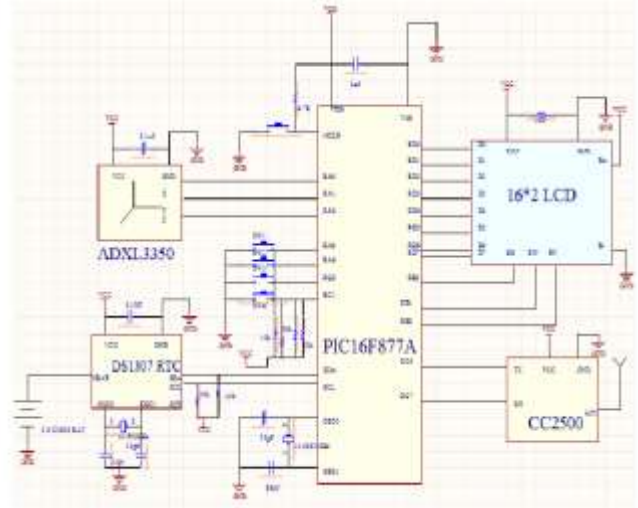

Receiver

7. Result

Transmission through RF (Radio frequency) is better than IR (infrared) because of many reasons. Firstly, signals through RF can travel through larger distances making it suitable for long range applications. Also, while IR mostly operates in line of sight mode, RF signals can travel even when there is an obstruction between transmitter & receiver distances making it suitable for long range

applications. This RF module comprises of an RF Transmitter and Receiver.

The transmitter/receiver (TX/RX) pair operates at a frequency of 2.4GHZ an RF transmitter receives serial data and transmits it wirelessly through RF through its antenna connected at **pin4**. The transmission occurs at the rate of 1Kbps-10Kbps. The transmitted data is received by an RF receiver operating at the same frequency as that of the transmitted.

8.Future Scope

In the receiver section a wireless camera is placed to monitor the performance of robot arm along with patient side (Robot arm side) 5 vital parameters (ECG, Respiration rate, Pulse rate, Temperature, Heart beat) of patient is monitored. This is a preventive measure for any imbalance in victim's metabolism (temperature, pressure, heart rate), ALARM in transmitter's section (physician side) will be ringing, which in turn brings into notice of physician that patient is in some critical situation, so that the physician immediately going to stops the action of robotic arm and he will inform the nearby doctors to take care of patient. This robotic arm developed is to reduce man power in medical field, take care of patient in absence of specialist/surgeon and to impart the robotic in medical areas.

References

[1] Seyed Eghbal Ghobadi, Omar Edmond Loepprich, Farid Ahmadov Jens Bernshausen, Real Time Hand Based Robot Control Using Multimodal Images, Iaengm International Journal Of Computer Science, 35:4, IJCS_35_4_08, nov 2008.

[2] Saurav Biswas, Umaima Rahman, Asoke Nath "A new Approach to Control a Robot using Android Phone and Colour Detection Technique", International Journal of Computer Science and

Information Technologies(IJCSIT), Vol.6(3), Page 2985-2989(June 2015).

[3] Song, M., Kim, B., Ryu, Y., Kim, Y., and Kim, S., "A design of real time control robot system using android Smartphone" The 7th International Conference on Ubiquitous Robots and Ambient Intelligence (URAI), BusanKorea, Nov. 2010.

[4] Aswath S, Chinmaya Krishna Tilak, Amal Suresh and GaneshaUdupa, "Human Gesture Recognition for Real-Time Control of Humanoid Robot", International Journal of Advances in Mechanical and Automobile Engineering (IJAMAE), Vol- 1, Issue 1, PP.96-100, (2014).

[5] Shruthi B. N, Shivraj, Sumathi S, "Hand Gesture Based Direction Control of Robocar using Arduino Microcontroller", International Journal of Recent Technology and Engineering(IJRTE), Volume-3, Issue-3,PP.-32-35, July 2014.

[6] GauravGautam, AbhijeetAshish, Anil Kumar, Avdesh, "Wirelessly Hand Glove Operated Robot", International Journal of AdvancedResearch in Electronics and Communication Engineering (IJARECE), Volume-3,Issue-11,PP.-1546-1547, November 2014.

[7] Harish Kumar Kaura, VipulHonrao, SayaliPatil, PravishShetty, "Gesture Controlled Robot using Image Processing", International Journal of AdvancedResearch in Artificial Intelligence (IJARECE), PP.-69-77, Vol-2, No.-5[2013].

[8] AdityaPurkayastha, Akhil Devi Prasad, Arunav Bora, Akshaykumar Gupta, Pankaj Singh, "Hand Gestures Controlled Robotic Arm", Journal of International Academic Research For Multidisciplinary, Vol-2, Issue-4, PP.-234-240, May 2014.

[9] Love Aggarwal, Varnika Gaur, PuneetVerma, "Design and Implementation of Wireless Gesture Controlled Robotic Arm with Vision", International Journal of Computer Application, Vol-79, No.-13, PP.-39-43,October 2013.

[10] RiyazMansuri, SandeshVakale, AshishShinde, Tanveer Patel, “Hand Gesture Control Robot Vechile”, IJECT, Vol-4, Issue SPL-2, PP. 77-80, JAN-MARCH 2013.

[11] Adithya Purkayatha, Akhil Devi Prasad, Arunav Barora, Akshay Kumar Gupta, Pravish Shetty,”Gesture controlled robotic arm”, Journal of Academic Research for Multidisciplinary, May 2014.

