

# TOUCHDOWN AVIATION POWER GENERATION

<sup>1</sup>Lavanya. J, <sup>2</sup>Manoj Prakash. P

<sup>1</sup>Undergraduate Student, Department of Electronics and Communication Engineering,  
SRM Institute of Science and Technology, Chennai, India.

<sup>2</sup>Undergraduate Student, Department of Computer Science and Engineering,  
SRM Institute of Science and Technology, Chennai, India.

**ABSTRACT:** Energy preservation is a standout amongst the most essential features of the 21st century. From organizations to people, everybody and everything should be considered responsible to their energy needs. Airports have a portion of the most important force utilization needs among institutions. We can outfit some of this unused breeze vitality and the weight produced via planes to create the power required to satisfy the power prerequisites of the air terminal. Touchdown sensors check where the airplane is landing and power is produced with the weight and effect from the vibration amid landing. The vitality is created by giving weight on the piezoelectric precious stones which brings about power age. The material is set on the runways in layers to detect vibration and give electric power/voltage with no electrical power input. At the point when planes take off and arrive, they let out a tremendous measure of vitality on the runway track. A lower control wind turbine can be introduced on the two sides of the runway to secure power. The electronic circuits included, and their yields, can be checked by utilizing Visual Basic programming. It can be actualized in metro airplane terminals to accomplish a vitality gathering framework, with the runway containing the touchdown sensors. The sensors can likewise be additionally customized to expand control age, in view of where the flying machine lands.

**IndexTerms:** Piezo-electric Sensor, power generation, LPWT, touchdown point.

## 1.INTRODUCTION

Every airport has a designated airstrip for touchdown i.e., the particular place where the airplane should land in the runway is called a touchdown point. In the existing system, these touchdown points are measured manually which is not of a great accuracy whereas in the proposed system these touch down points are calculated by the help of visual basic software which uses GUI. This method is highly useful as it not only calculates the touch down points but measures the pressure exerted by an airplane and other factors. This can be used to further reduce the accidents in runways.

### 1.1 Touchdown aviation:

The pressure exerted by the airplane can be converted to energy by using a piezo electric sensor which can be placed in the form of sheets underneath the touch down points. These sensors convert the pressure to voltage thereby generating certain amount of power which can be used to light up the taxi-ways and so on thus making the airports more self-sustaining. The excess harvested energy can always be sent to the state power grid for other commercial and residential purposes. Another addition to this is by installing LPWT (low power wind turbines) on both sides of the runway of the airport to conserve power during the take-off and landing of aircrafts. As the speed of an aircraft ranges from 300-500 nautical miles per hour on runway, it drives out huge amount of velocity that is enough for small micro scale wind turbines to produce power.

### 1.2 Micro scale wind turbines:

The rotatory motion of the shaft rotates the motor which is converts mechanical energy to electrical energy. They are small and light in weight as compared to other types of wind turbines. Some units have been designed to be very lightweight in their construction, e.g. 16 kilograms (35 lb), allowing sensitivity to minor wind movements and a rapid response to wind gusts typically found in urban settings and easy mounting much like a television antenna. It is claimed, and a few are certified, as being inaudible even a few feet (about a metre) under the turbine.

### 1.2 Piezo electric materials:

The prefix piezo-is Greek for 'crush' or 'press'. A piezoelectric sensor is a gadget that controls the piezoelectric impact, to quantify the adjustment in weight, rushing, temperature, strain, and power by changing over it to an electrical charge. They have wide recurrence and adequacy run.

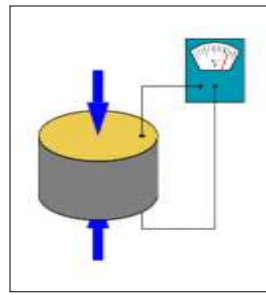

FIG 1.3.1: Piezoelectric mechanism



FIG 1.3.2: Piezoelectric sensor

### 1.3 Principle of Conversion:

Large amount of pressure is exerted on runways during touchdown and aviation. If we are placing the piezoelectric material at this point in layers then we can be able to convert the mechanical generation from the vibrations created by an aircraft on the runway into electrical energy. These electrical signals are converted into data signals by using data transmitters which is connected to computer system using RS-232 cable port. This data is read by the visual basic software which measures the pressure exerted, power, voltage and current generated by the particular system. A graph is generated to measure the current and voltage. Wind turbines are placed on the either side of the runway. The rotatory motion of the shaft in a windmill that is used to rotate the turbine and convert it into energy.

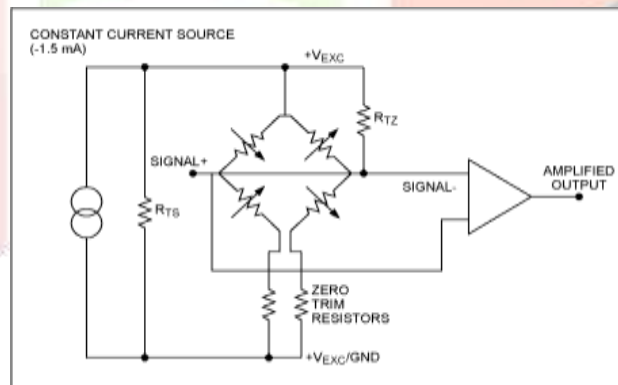

Fig 1.4 Circuitry of conversion of pressure into current

### 1.4 Hardware requirements:

- Microcontroller-PIC16F877A: PIC16f877A discovers its applications in a various number of gadgets. It is utilized as a part of remote sensors, security and wellbeing gadgets, home mechanization and in numerous modern instruments. An EEPROM is likewise included in it which makes it conceivable to store a portion of the data for all time like transmitter codes and beneficiary frequencies and some other related information.

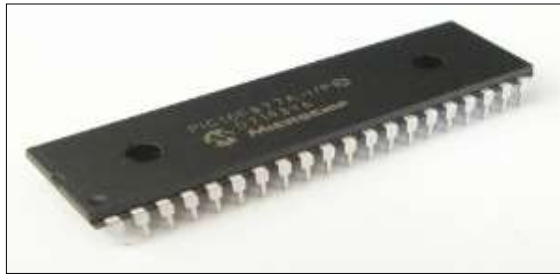

FIG: 1.5.1 PIC16F877A

There are 40 pins of this microcontroller IC. It consists of two 8 bit and one 16 bit timer. Capture and compare modules, serial ports, parallel ports and five input/output ports are also present in it.

- Piezoelectric sensor: Sensors identify or measure (or at times distinguish and measure) physical amounts, for example, remove, weight, movement, and temperature. They play out their activity by means of transformation. For instance, a thermocouple changes over a temperature into a discernible voltage. Piezoelectric sensors depend on the piezoelectric impact to quantify a plenty of parameters, for example, weight, strain, or power by, indeed, changing over them to voltages. Actually, one can reasonably say that piezoelectric sensors and transducers are one and the same. Transducers change over vitality starting with one shape then onto the next. Piezoelectric transducers work both ways. They can change over mechanical vitality, for example, weight and vibration to electrical vitality like voltage or current. They likewise can work backward, changing over electrical vitality into mechanical vitality, for example, sound or vibration.
- Transformer- 230V: This is utilized to give voltage security and over-burden resistance. Transformers change the voltage coming into the circuit to the correct level, and draw the power through the circuit to keep it working legitimately.
- Bridge Rectifier: A Bridge rectifier is an Alternating Current (AC) to Direct Current (DC) converter that amends mains AC contribution to DC yield. Scaffold Rectifiers are generally utilized as a part of energy supplies that give important DC voltage to the electronic segments or gadgets. They can be built with at least four diodes or some other controlled strong state switches.

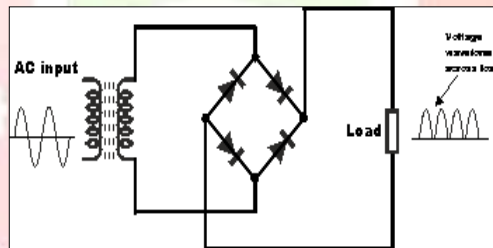

FIG 1.5.2 Bridge rectifier circuit

- Transistor SL100 : SL100 is a universally useful, medium power NPN transistor. It is for the most part utilized as switch in like manner producer setup. The transistor terminals require a settled DC voltage to work in the coveted district of its trademark bends. This is known as the biasing. For exchanging applications, SL100 is one-sided such that it remains completely on if there is a flag at its base. Without base flag, it gets killed totally. The producer leg of SL100 is shown by a jutting edge in the transistor case. The base is closest to the producer while gatherer lies at other extraordinary of the packaging.

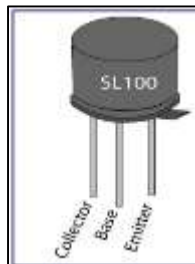

FIG 1.5.3 Transistor SL100

- Connector RS232 and RS232 Port: An **RS-232** serial port was once a standard feature of a personal computer, used for connections to modems, printers, mice, data storage, uninterruptible power supplies, and other peripheral devices.

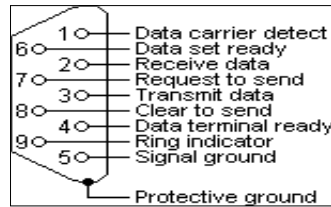

FIG 1.5.4 RS232 port pin diagram

- Finally, we require a PC to display the results provided by the components with the help of Visual Basic 6.0 software.



FIG 1.5.5 Sample output of the system

**1.6 System Architecture:**

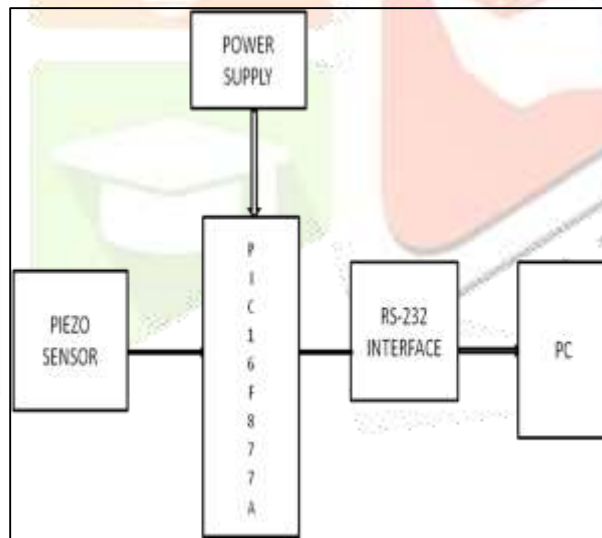

FIG 1.6 System Architecture of the circuit

**1.7 Visual Basic:**

In Visual Basic 6.0, the Visual part refers to the method used to create the Graphical User Interface (GUI). As a substitute in writing numerous lines of code to describe the appearance and location of interface elements, we simply add Pre built Objects in the required place on the screen. The Basic part refers to the BASIC (Beginners All- purpose Symbolic Instruction Code) language, used by many users than any other language in the History of Computing. This programming language is preferred over embedded c because it reduces the complexity of code writing.

```

Pegol.PeString.SubsetLabels(0) = "For .NET Framework"
Pegol.PeString.SubsetLabels(1) = "or MVC, ActiveX, UCL"
Pegol.PeString.YAxisLabel = "Simple Quality Rendering"
Pegol.PeColor.SubsetColors(0) = System.Drawing.Color.FromArgb(60, 0, 100, 0)
Pegol.PeColor.SubsetColors(1) = System.Drawing.Color.FromArgb(100, 0, 0, 100)
Pegol.PeColor.BitmapGradientMode = False
Pegol.PeColor.QuickStyle = Gigasoft.Professionals.Enums.QuickStyle.LightShadow
Pegol.PeTable.Show = Gigasoft.Professionals.Enums.GraphPlusTable.Both
Pegol.PeData.Precision = Gigasoft.Professionals.Enums.DataPrecision.NoDecimals
Pegol.PeFont.Label.Bold = True
Pegol.PePlot.Method = Gigasoft.Professionals.Enums.GraphPlottingMethod.Bar
Pegol.PePlot.Option.GradientBars = 8
Pegol.PePlot.DataShadows = Gigasoft.Professionals.Enums.DataShadows.ThreeDimens
Pegol.PeFont.FontSize = Gigasoft.Professionals.Enums.FontSize.Large
Pegol.PeUserInterface.HotSpot.Data = True
Pegol.PeLegend.Location = Gigasoft.Professionals.Enums.LegendLocation.Left
Pegol.PePlot.Option.BarGlassEffect = True
Pegol.PeConfigure.RenderEngine = Gigasoft.Professionals.Enums.RenderEngine.GDI
Pegol.PeConfigure.AntiAliasGraphics = True
Pegol.PeConfigure.AntiAliasText = True
Pegol.PeFunction.InitializeResetImage()
Pegol.Refresh() 'call standard .NET Refresh method to force paint

```

Fig 1.7 Sample code for generating graphical interface in Visual Basic

### 1.8 Working:

From fig: 1.6, The Piezo sensor senses the pressure generated by the aircraft and converts it into voltage which is generates alternating current, and this alternating current is fed to the bridge rectifier of the system which converts it into DC and the piezo sensor system sends the respective analog signals to PIC16F877A micro-controller that converts it into digital signals and the respective digital signals is sent to computer through a RS232 cable. The provided output is represented in graphical form by VISUAL BASIC software which is embedded with the hardware components.

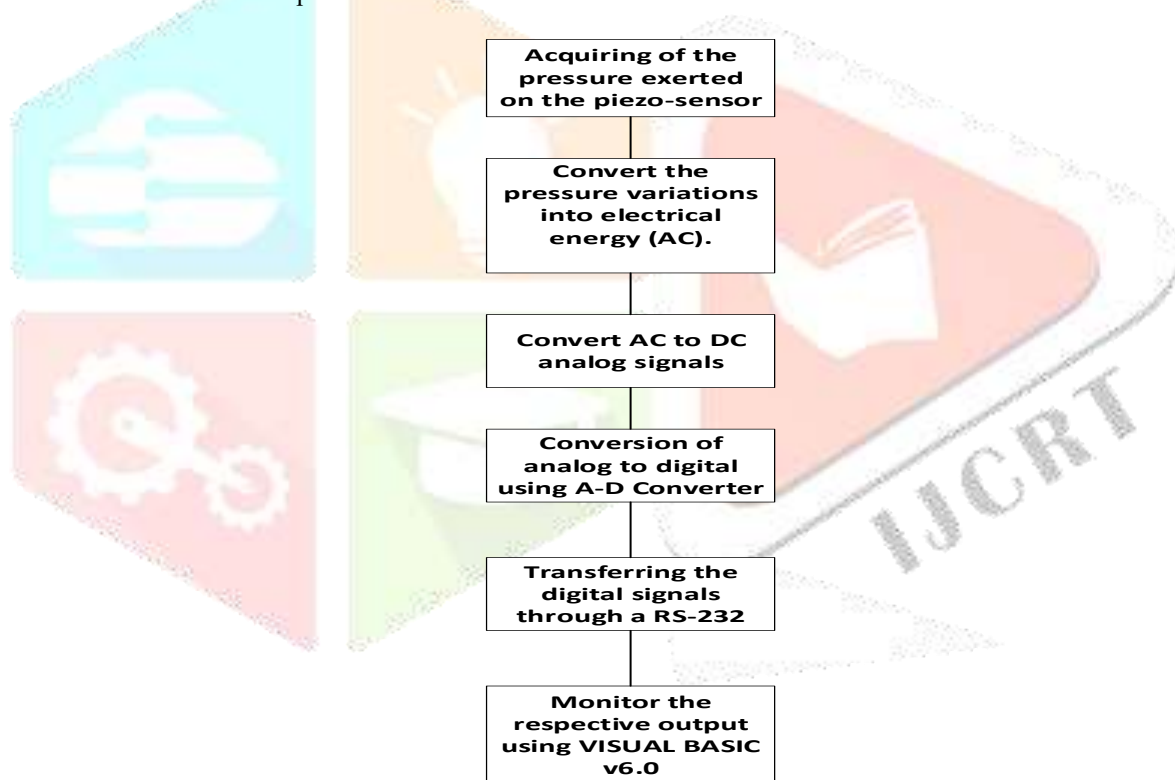

Fig 1.8: Workflow of the system

### 2. Advantages:

- 1) the seasonal wind energy can now be harnessed all through the year.
- 2) It is a clean and renewable source of energy.
- 3) Operating and maintenance cost is low.
- 4) The usage of thermal electricity can be minimized which in turn reduces the usage of non-renewable resources.
- 5) Reduces the environmental pollution.
- 6) We can electrify the most untouched remote areas of the country.
- 7) It can make the airports self-sustaining thereby reducing the power needs for airports.



### **3. Future enhancements:**

As one aircraft can weigh between 500-600 tonnes, it can produce a minimum of 250kV of energy at one time. If we consider the total number of aircraft touchdowns at an airport in one day nearly 8500kWh energy could be produced which can power up to 17000 homes. This is a dual energy conservation technique which will lead to a new era of energy conservation system. If implemented this project will prove to be the efficient power generating mechanism for the country. To transfer large bits of data over distance we can use fibre optic cables for a better efficient communication between piezo systems and the computer.

### **4. Applications:**

- 1) The power which is not utilised by the airports can be efficiently used for other commercial and residential purposes.
- 2) It can be used to detect earthquakes by measuring the seismic vibrations generated.
- 3) It can be used for strain gauge and so on.
- 4) It can be used in several other fields to produce energy such as we can use it in pedestrian footpaths, gym equipments etc.

### **5. Conclusion:**

The concept can be evaluated and completely analysed with the software used and also can be implemented in metro airports to achieve green and clean energy harvesting system with the self-powered runway with the automated touchdown zone. It uses touchdown sensors to automate the aircraft landing and power is generated with the pressure and impact from the vibration during landing. The efficient way of using the alternative source of power generation and which can be made with centralized distribution to all the other commercial and residential purpose from the power generated in airport. This project could have a complete solution for the existing system with the improved efficiency and automation for the social and safety welfare of the country.

### **6. References:**

- [1]. Airport Authority of India. [2012] Manual of Aeronautical Information Services, Technical information with case study, Jan 2012.
- [2]. "A Unique Step Towards Generation of Electricity via New methodology," International Journal of Advanced Research in Computer and Communication Engineering, Vol. 3, Issue 10, October 2014.
- [3]. "NTSC (National Transport Safety Committee) – Aircraft Accident Investigation Report," Enhancement of Aviation Safety, June 2013.
- [4]. "AeroMACS Evolution- Analysis during Landing, Takeoff and Approach Phases," IEEE Transactions on Aerospace and electronics.
- [5]. "Risk Analysis of Runway overruns Excursions at Landing: Case Study," Department of Statistics and Operations Research, Rey Juan Carlos University, 2011.
- [6]. Al-AmeenSalih, Zhahir A, Ahmad MT.[ 2013] "Modeling and Simulation of a high Accurate Ground based positioning and Landing System", Space Science and Communication, IEEE International Conference.
- [7]. Jin Tian and Tingdi Zhao.[2012] "Controllability – involved risk assessment model for carrier landing of aircraft", IEEE proceedings.
- [8]. Tom Tucker.[ 1999]Touchdown: "The Development of Propulsion Controlled Aircraft At NASA Dryden, Monographs in Aerospace History".