

WIRELESS E-NOTICE BOARD

G. Mounika¹, K .Rajesh², V.Nandini³, Y. Ashok⁴, k. venkateswara rao
U.G. Student, Department of ECE, CIET, Lam, Guntur¹
Assistant Professor, Department of ECE, CIET, Lam, Guntur²
U.G. Student, Department of ECE, CIET, Lam, Guntur^{3,4,5}

Abstract:

Notice board is primary thing in any institution or organization or public utility places like bus stops, railway stations or parks. But sending various notices day to day is a tedious process.

This project deals with advanced notice board. It presents a Bluetooth based E notice board. Bluetooth technology is to exchange information between or amongst devices. The information can be a text file, media file or any normal text. Bluetooth play a very important role in wireless communication.

The messaged is thus fetched into the microcontroller. It is further displayed on an electronic notice board which equipped with LED display interfaced to micro controller through TTL to serial converter by a regulated power supply from mains supply of 230 volts ac. This project helps to reduce usage of paper and man power.

Keywords: E-notice board

INTRODUCTION

In this world mobile phones and the related technologies are becoming more and more prevalent. Various technical arenas in the field of Telecommunication and embedded system are becoming omnipresent in the people. The use of cell phones has rapidly increased over the last decade and a half. Up gradation in networking technologies has encouraged the development and growth of very dense networks. Now a days the general mass prefers communicating while on the move therefore landlines usage has been drastically reduced.

Notice boards are one of the widely used ones ranging from primary schools to major organizations to convey messages at large. A lot of paper is been used and which is later wasted by the organizations. This in turn leads to a lot of deforestation thus leading to global warming. Small innovative steps in making use of technology for regular purposes would have an adverse effect on the environment issues which we are presently concerned about. The main aim of this paper is to design a SMS driven automatic display Board which can replace the currently used programmable electronic display and conventional notice boards.

It is proposed to design to receive message in display toolkit which can be used from an authorized mobile phone.

The whole process can be described from the transmitter and receiver section. The BLUETOOTH module receives a message from the authorized mobile phone and the message is extracted by the microcontroller

1. Block diagram

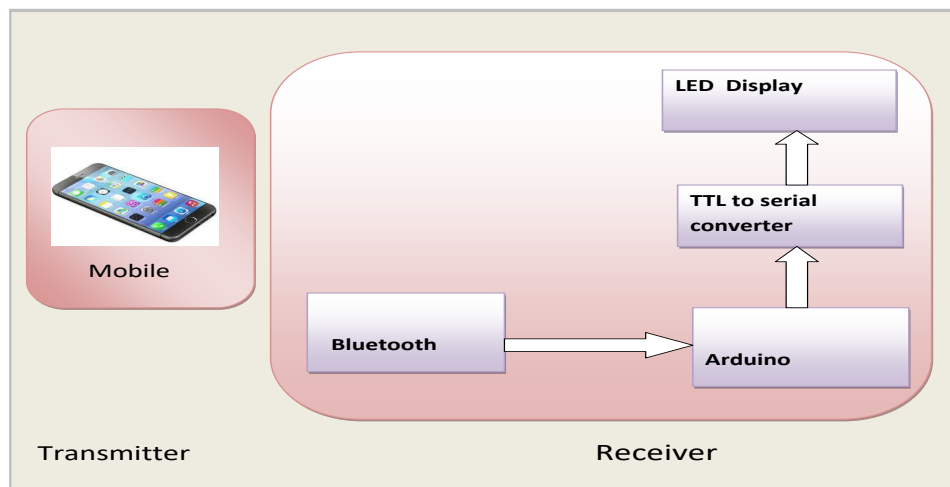

SYSTEM REQUIREMENT

HARDWARE

- MOBILE
- BLUETOOTH
- ARDUINO NANO
- MAX232
- LED DISPLAY

SOFTWARE

- ArduinoIDE

LANGUAGE

- Embedded C

1.1 mobile Mobile phones are an integral part of our daily communications. All mobile phones have the capacity for voice and simply text messaging services. Their small size, relatively low cost and many uses make these devices invaluable for rights advocates who increasing use them for communication and organization



1.2 Figure2:Mobile

1.2 Bluetooth:

In transmitter section we use mobile for the sake of Bluetooth. Bluetooth silently connects so many of our gadgets together, it's easy to forget it's a pretty impressive piece of technology on its own. It helps us listen to music, talk on our phones.

Looking to free your hands up? Check out our list of the best Bluetooth headsets so you can explain to people that you aren't talking yourself.

Bluetooth module HC-05:

HC-05 Bluetooth Module is an easy to use Bluetooth SPP (Serial Port Protocol) module, designed for transparent wireless serial connection setup.

Its communication is via serial communication which makes an easy way to interface with controller or PC. HC-05 Bluetooth module provides switching mode between master and slave mode which means it able to use neither receiving nor transmitting data.

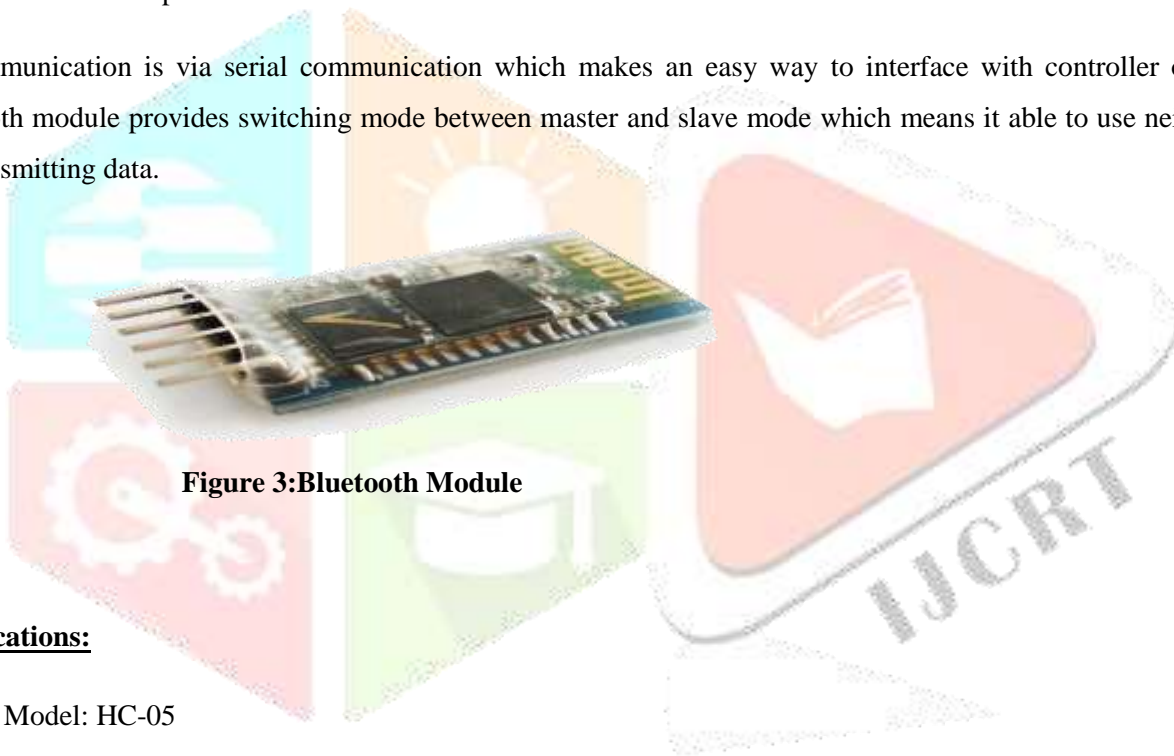

Figure 3:Bluetooth Module

Specifications:

- Model: HC-05
- Input Voltage: DC 5V
- Communication Method: Serial Communication
- Master and slave mode can be switched.

Bluetooth HC-05 pin description:



Table 1: About pin connections

Pin	Description	Function
VCC	+5V	Connect to +5V
GND	Ground	Connect to Ground
TXD	UART_TXD, Bluetooth serial signal sending PIN	Connect with the MCU's (Microcontroller and etc) RXD PIN
RXD	UART_RXD, Bluetooth serial signal receiving PIN	Connect with the MCU's(Microcontroller and etc) TXD PIN
KEY	Mode switch input	If it is input low level or connect to the air, the module is at paired or communication mode. If it's input high level, the module will enter to AT mode

1.3 Arduino Nano:

The arduino nano is a small, complete and breadboard-friendly board based on atmega328p(Arduino nano 3.x). It has more or less the same functionality of the arduino Duemilamove, but in a different package. It lacks only a DC power jack, and works with a mini-B USB cable instead of a standard one.

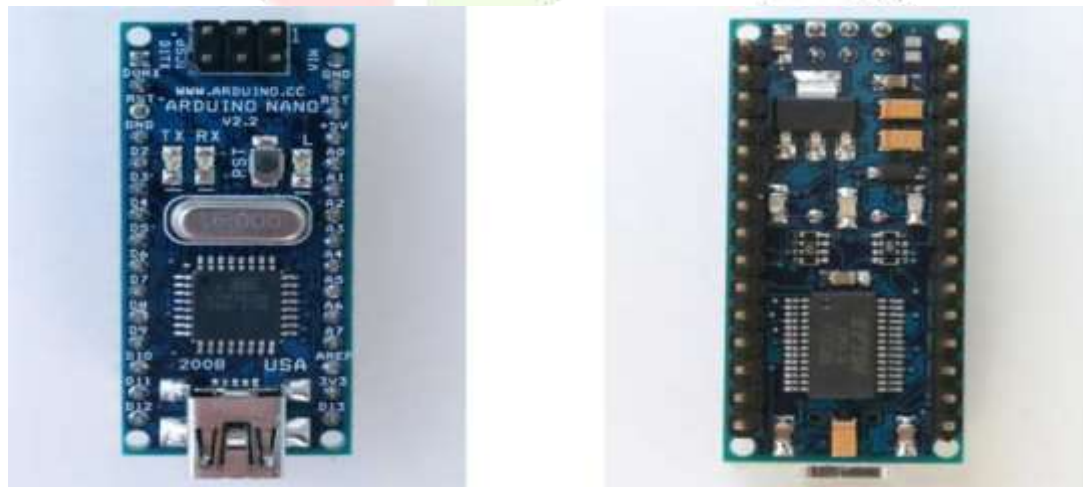

Figure 4: Arduino Nano

1.3 pin description:

Microcontroller	:Atmel ATmega168 or ATmega328
Input Voltage (recommended)	:7-12V
Input Voltage (limits)	:6-10V
Digital I/O Pins	:14 (of which 6 provide PWM
Analog Input Pins	:8
C Current per I/O Pin	:40 Ma
SRAM	:1KB
EEPROM	:512 bytes (ATmega168) or 1 KB
(ATmega328) Clock Speed	:16 MHz
Dimensions	:0.73" x 1.70"

1.4 MAX232 WITH DB9 CONNECTOR:

The MAX232 replaced an older pair of chips MC1488 and MC1489 that performed similar RS-232 translation. The MC1488 quad transmitter chip required 12 volt and -12 volt power,^[11] and MC1489 quad receiver chip required 5 volt power.^[12] The main disadvantages of this older solution was the +/- 12 volt power requirement, only supported 5 volt digital logic, and two chips instead of one.



Figure 5: max232 with db9 connector

Pin description of MAX232

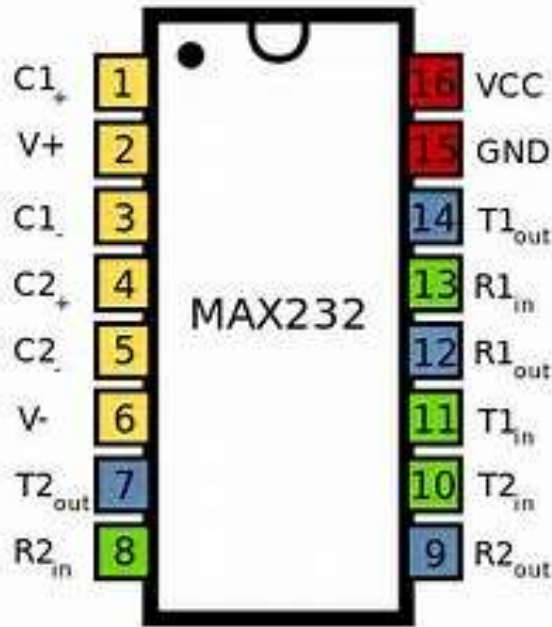

Figure 6: pin description of max232

1.5 LED display:

- An LED display, or light emitting diode display, is a flat panel display that uses light emitting diodes as the video display.
- An LED display panel can be either a small display or part of a larger display.
- LED diodes are used in order to make up an LED display.
- LED displays are also used in billboards and store signs.

2.INTERFACING OF HARDWARE COMPONENTS:

2.1 interfacing of arduino and Bluetooth:

- This circuit is simple and small. There are only four connections to be made between the Arduino and Bluetooth module!

Arduino Pins		Bluetooth Pins
• RX (Pin 0)	————>	TX
• TX (Pin 1)	————>	RX
• 5V	————>	VCC
• GND	————>	GND

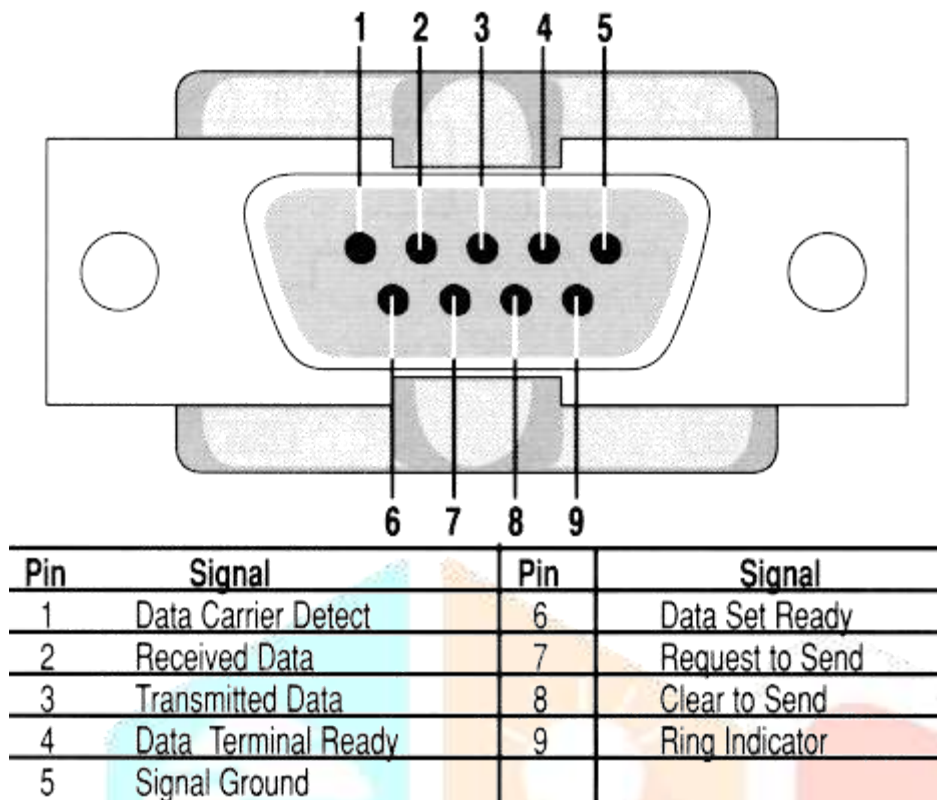

Figure 9:DB 9 serial convertor pin diagram

3.ADVANTAGES

- E-notice Boards are used in a multitude of businesses, such as schools, hospitals and hotels, as they can be used over and over again to display important notices .
- From very basic notice boards to the more premium boards, which are superbly built using the highest quality materials for reliability and extended use

4. websites:

<http://arduino.cc/>

<http://crackeconcept.blogspot.com/2014/03/arduino-and-matlab-interfacing-via.html>

<http://play.google.com/store/apps/details?id=arduino.control.device>

<http://www.c-sharpcorner.com/UploadFile/167ad2/how-to-use-hc-05-bluetooth-module-with-arduino/>

<http://circuitdigest.com>

<http://www.hobbyprojects.com>

5.journals:

1. International journal of trend and development, volume4 (1), ISSN.
2. International journal of innovative research in computer and communication engineering (An ISO 3297:2007 certifie3d organization).
3. International journal of advanced engineering and research Development, volume 4, Issue 5, May-2017.

4. International Research journal of engineering and Technology (IRJET), Volume: 03:12, Dec-2016.
5. International journal of advent research in computer and electronics (IJARCE), VOL 2, No. 1, April 2017.
6. International journal for research in applied science & engineering Technology (IJRASET).
7. International journal for scientific research(IJSR).
8. Internation journal for scientific research and development (IJSRD), vol 4, Issue 01, 2016(ISSN: 2321-0613).

6.CONCLUSION

From this experiment, we conclude that the Arduino Uno with the Bluetooth module and relay driver works very well. This project is used in colleges, bus station, railway stations and public places. It reduces the man power. And also reduces the usage of paper. This we do not want cut many tress.

7.Results:

