

# STRADDLE BUS

<sup>1</sup>Bhange Shyam,<sup>2</sup>Dhakane Vishal,<sup>3</sup>Joshi Shubham,<sup>4</sup>Gambhire Vimal,<sup>5</sup>Prof. Nidhi Mishra

<sup>12345</sup>Department of Electrical Engineering

<sup>12345</sup>JSPM'S Bhivarabai Sawant Institute of Technology and Research Wagholi, Pune-412207

## **Abstract:**

The renewable energy is vital for today's world as in near future the non renewable sources that we are using are going to get exhausted. Nowadays, we are experiencing an electricity scarcity we are experiencing a lead in shortage too. So the battery manufacturing cost and resulting end user prices are sky high also a shortage of batteries in the market. We are also experiencing a hike in fuel prices considerably, is bound to go on as time pass by as soon we will be shortage of fuel too. There is an emphasis on using fuel appreciably but nobody is taking care of it.

But we are at least taking the consideration of it and with this we are trying to put a novel concept in the market. The solar train is a step in saving these non renewable sources of energy. In India where weather is mostly sunny and sunlight is available whole year, it's a very good idea to use solar energy for the purpose of transportation.

We propose an electricity supply system suitable for public transportation. In this system, solar cells are installed on the rooftop of the trains. We provide solar panels on the roof of the coach to directly charge the storage battery mounted under slung at each coach. There are many doubts about viability and applicability of such provisions. Nowhere in any of the railways world over, self-generating coaches are in service, therefore, there is no possibility of getting the ready-made technology from abroad and has to be tried and developed in India only. The developed countries are already experimenting use of solar power for road vehicle and aircraft, which gives confidence for its viability. Bendable solar panels which can be pasted on the coach roof without affecting maximum moving dimension will serve the purpose.

**Keywords:** RF Module, IR Sensor, Relay, Solar Panel, Battery.

## **1. INTRODUCTION**

Energy is one of the most vital needs for human survival on earth. We are dependent on one form of energy or the other for fulfilling our needs. One such form of energy is the energy from fossil fuels. We use energy from these sources for generating electricity, running automobiles etc. But the main disadvantages of these fossil fuels are that they are not environmental friendly and they are exhaustible. To deal with these problems of fossil fuels, we need to look at the Non-Conventional Sources of energy. With regard to this idea we have designed a train that runs on solar energy.

Many specifications must to know about solar train from solar array, motor, battery and so on each specification has theory and calculation to make it function correctly & able to move perfectly. This project a lot depends on solar panel because it using influence if the solar train can drive or not.

Using brain storming techniques to generate ideas, several initial design may be consider a common place to start is with the shape of the train since it will dictate the design of many other system initial designing concept are also developed for chassis design mechanical system design, electric system design, driving train design & solar array design that show promise are investigated further so that design can be compare through trade of studies the concept must be eliminated until a final design can be agreed upon there are many factors to consider to each design, for example:

- Weight
- Efficiency
- Speed

Knowledge about solar array also important because the array is made up of many photovoltaic solar cell that convert sun energy into electricity. The cell types & the dimensions of the array depends on the vehicle size and class.

2. HARDWARE COMPONENT

- I. RF TX RX
- II. RELAY
- III. PROBLEM STATEMENT
- IV. IR SENSOR
- V. MOTOR

I. RFTX:

An RF module (radio frequency module) is a (usually) small electronic device used to transmit and/or receive radio signals between two devices. In an embedded system it is often desirable to communicate with another device wirelessly. This wireless communication may be accomplished through optical communication or through radio frequency (RF) communication. For many applications the medium of choice is RF since it does not require line of sight. RF communications incorporate a transmitter and/or receiver.

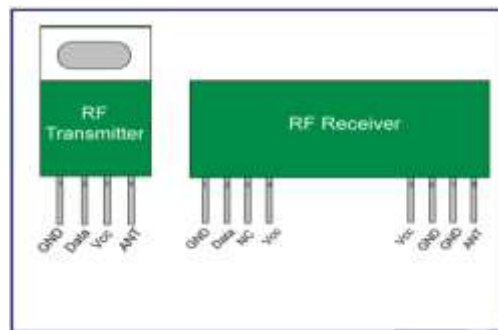

Fig. Rf Tx Rx Module.

- One of the major problems faced by the Indian urban cities is the problem of traffic congestion.
- A big concern is how to speed up the traffic.
- Putting more buses on the road will jam the roads even worse and pollute the air.

3. BLOCK DIAGRAM

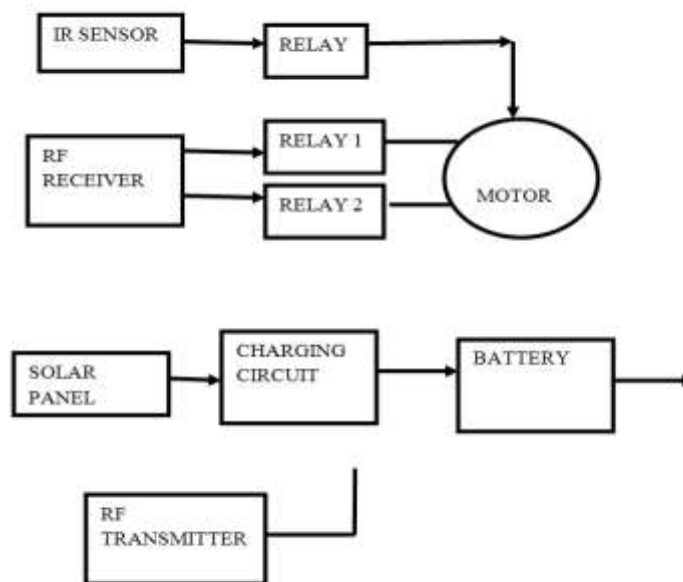

Fig. Block Diagram

## BLOCK DIAGRAM DESCRIPTION

- Here we are using solar panel. by using the solar energy it will reduce the traffic jams 20% to 30%.
- Rf Module Is Used Here.
- If IR sensor detect an track fault at that time automatically cut power. bus will stop.

## II. DC MOTOR:

A DC motor is any of a class of electrical machines that converts direct current electrical power into mechanical power. The most common types rely on the forces produced by magnetic fields. Nearly all types of DC motors have some internal mechanism, either electromechanical or electronic; to periodically change the direction of current flow in part of the motor. Most types produce rotary motion; a linear motor directly produces force and motion in a straight line.

DC motors were the first type widely used, since they could be powered from existing direct-current lighting power distribution systems. A DC motor's speed can be controlled over a wide range, using either a variable supply voltage or by changing the strength of current in its field windings. Small DC motors are used in tools, toys, and appliances. The universal motor can operate on direct current but is a lightweight motor used for portable power tools and appliances. Larger DC motors are used in propulsion of electric vehicles, elevator and hoists, or in drives for steel rolling mills. The advent of power electronics has made replacement of DC motors with AC motors possible in many applications.

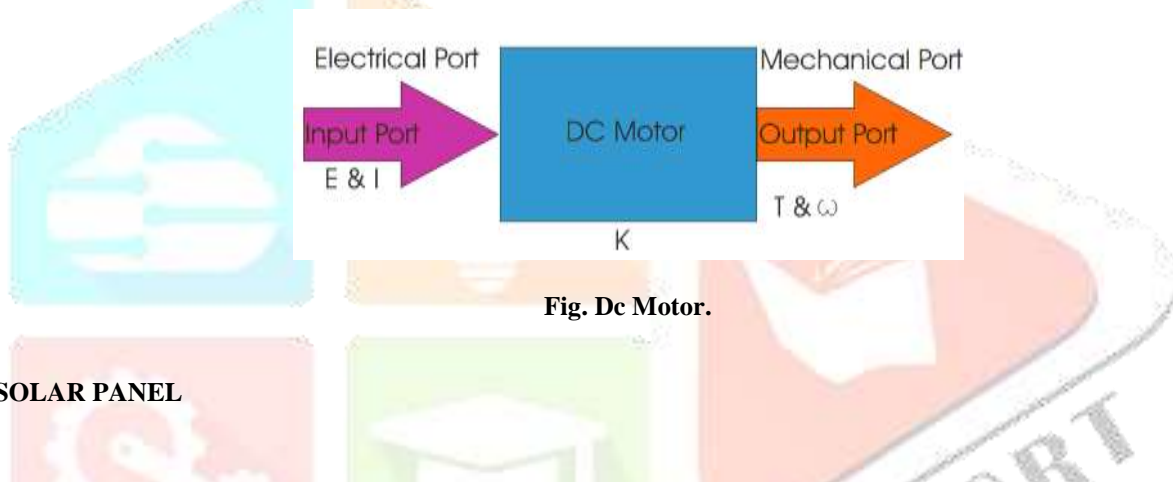

**Fig. Dc Motor.**

## III. SOLAR PANEL



**Fig.Solar Panel**

A solar panel pumps electricity into a battery that stores it, but the solar panel has no control over how much it does or how the battery receives it. The charge controller (charge regulator) positioned between the solar panel and the battery regulates the voltage and the current and essentially halts charging activity temporarily when necessary. Solar panels are connected through an Array Combiner.

## IV. IR SENSOR

Proximity Sensor is used to detect objects and obstacles in front of sensor. Sensor keeps transmitting infrared light and when any object comes near, it is detected by the sensor by monitoring the reflected light from the object. It can be used in robots for obstacle avoidance, for automatic doors, for parking aid devices or for security alarm systems, or contact less tachometer by measuring RPM of rotation objects like fan blades.



Fig. IR Sensor

#### 4. OBJECTIVES

- It is cheaper And construction takes less time.
- It saves road spaces,efficient,
- And high in capacity
- Travelling with this buseswill consume less time.
- And hence it is more sophisticated

#### 5. NEED IN INDIA

- India is second largest country in population .
- In India measure cities facing traffic jams due to density of population.
- By implementation of straddle bus of system pollution, traffic jams can be minimizing as well as cost of fuel will reduces. This tends to less fuel consumptions.
- Construction period of straddle bus is very less.

#### 6. ADVANTAGES

- Solar energy is renewable and freely available.
- Traffic reduced by 30%.
- Construction period required is very less.
- 860 tons of fuel consumption and fuel cost is saved by implementing this system
- Fuel source for Solar Panel is direct and endless so no external fuels required.
- Unlimited life of Solar Modules, fast response and high reliability.
- Can operate under high temperature and in open.
- Inherently short circuit protected and safe under any load condition.
- Pollution free.
- Minimum Maintenance
- Independent working
- Noise-free as there are no moving parts.
- No AC to DC conversion losses as DC is produced directly.

#### 7. CONCLUSION

The straddle bus is used very rarely, at present there is only Mexico has 40 km line and china have tested it successfully in 2010 . Though they have beenaround for about few years only, the technology is still in the developmental stages.Hence they cannot be used as a practical means of traction. So here is the conclusion that the challenge lies in making it a viable means of transport. Further research is needed inthis regard to improve solar panels, increase efficiency, and reduce weight, to improvereliability and to reduce the cost. Research is being carried out on many semi-conductors and their alloys to develop more efficient solar cells. Thus this technology will definitelylive up to its potential sometime in the future.

#### REFERENCES

- 1] Guruprasad Patil <sup>1</sup>, Dr.C.R Rajashekhar <sup>2</sup> - RFID Based Metro Train System , International Journal of Advancements in Research & Technology, Volume 3, Issue 5, May-2014 ISSN 2278-7763

- 2] Akshatha R. , Dr. J Meenakumari -Enhanced &Integrated E-Ticketing - An One Stop Solution, International Journal of Advance Research in Computer Science and Management Studies, Volume 3, Issue 6, June 2015
- 3] Prakash Ratan , Chandra Jogi - Auto Metro Train to Shuttle Between Stations - International Journal & Magazine of Engineering, Technology, Management and Research , Volume No: 2 (2015), Issue No: 5 (May)
- 4] R.Valarmathi, G.Karthika -Smart Ticketing System in Metro Rail -International Journal of Advanced Research in Electrical, Electronics and Instrumentation Engineering , Vol. 3, Special Issue 3, April 2014

