

WIRELESS SOLAR POWER MONITORING USING EMBEDDED SYSTEM

¹Durga Prasanna Mohanty, ²Gopinath Das

¹ Asst. Professor, ²M.Tech Scholar,

¹Department of EE/EEE

¹Raajdhani Engineering College, Bhubaneswar, India

Abstract: To improve the utilization of solar power energy resources, Solar Power monitoring system is important. In this paper we discussed Data monitoring in solar power system is performed by combination of processor chip of ARM 7 family and GPRS wireless Communication. The ARM 7 processor LPC2148 is used for data automatic analysis, processing, displaying and saving automatically whereas GPRS wireless communication device is responsible for real time data transmission to the monitoring center. This system monitors the ambient temperature around solar power generation equipments, the Backplane temperature, and Humidity, solar irradiation, generated Current & Voltage. Here the system not only made the data transmission to the monitoring center in real time & effectively but also realize the unmanned watching.

Index Terms - Data monitoring system; ARM 7; GPRS

I. INTRODUCTION

Solar power is emerging as the number one competitive renewable energy resource, so to improve the utilization of solar energy resources, solar power monitoring systems is more important. Photovoltaic solar panels are increasing in popularity and users need accurate information of their solar energy installation. Currently, most residential solar panel systems only provide energy information on a monthly basis and do not allow individual panel monitoring. PV solar panel has at least 25 years warranty, whereas inverters only come with an 8-10 years warranty. That means that sometime in the 8-10 years range the inverter will die and the system will stop producing energy. With a monitoring system in place the installer or homeowner will know immediately that the system has been compromised. Otherwise it could be weeks or months before the home owner looks at their energy usage statement from their utility company and realizes that their solar electricity system is not longer producing energy. Other problems are arrives when solar power monitoring system is not in use and that problems are related to the battery charging and discharging states. Overcharging of battery will produces Gasification and that will reduces the effective capacity of battery, whereas over discharging will produces Hard Sulfation. As result of sulfation it generates big crystals on battery plate which do not take part in any chemical reaction and can make battery unusable. So, it is very important to get more information about solar panel performance, tracking and maintenance.

II. THE EMBEDDED PROCESSOR ARM7

The LPC2148 microcontrollers are based on a 32/16 bit ARM7TDMI-S CPU with real-time emulation embedded trace support that combines the μ c with embedded high speed flash memory ranging from 32 kB to 51 kB. A 128-bit wide memory interface and unique accelerator architecture enable 32-bit code execution at the maximum clock rate. They are small size and have low power consumption . The LPC2148 are ideal for applications where miniaturization is a key requirement, such as access control and point-of-sale. A blend of serial communications interfaces ranging from a USB 2.0 Full Speed device, multiple UARTs, SPI, SSP to I2Cs, and on-chip SRAM of 8 kB up to 40 kB , make these devices very well suited for communication gateways and protocol converters, soft modems, voice recognition and low end imaging. It has various 32-bit timers, single or dual 10-bit ADC(s), 10-bit DAC, PWM channels and 45 fast GPIO lines with up to nine edge or level sensitive external interrupt pins. Crystal Frequency is ranging from 1MHz to 30MHz and two low power mode i) Idle mode ii) Power down mode.

III. System Design

In this system the core processor LPC2148 collects the data from different sensors such as ambient temperature around solar power generation equipments, solar irradiance, humidity, generated voltage and current from solar panel, battery voltage and current. Here LPC2148 processor is responsible for data automatic analysis, processing, displaying and sending to the monitoring centre by using wireless communication technique. GPRS [sim900] is used for wireless communication. At the monitoring centre the received data is displayed in graphical way as well as it will save in the database. For graphical representation has been used as VB6.0 & for database SQL server. This proposed system continually monitors the temperature around the solar panel and when temperature reaches to 130 centigrade then the processor turns on cooling system. Similarly this system monitors the battery charging state, as the battery reaches to its maximum level then processor stopped charging current battery and switched to the next battery. The main feature of this mechanism is continues monitoring of solar system as well as controlling action will take place against faults occurring in some parameter.

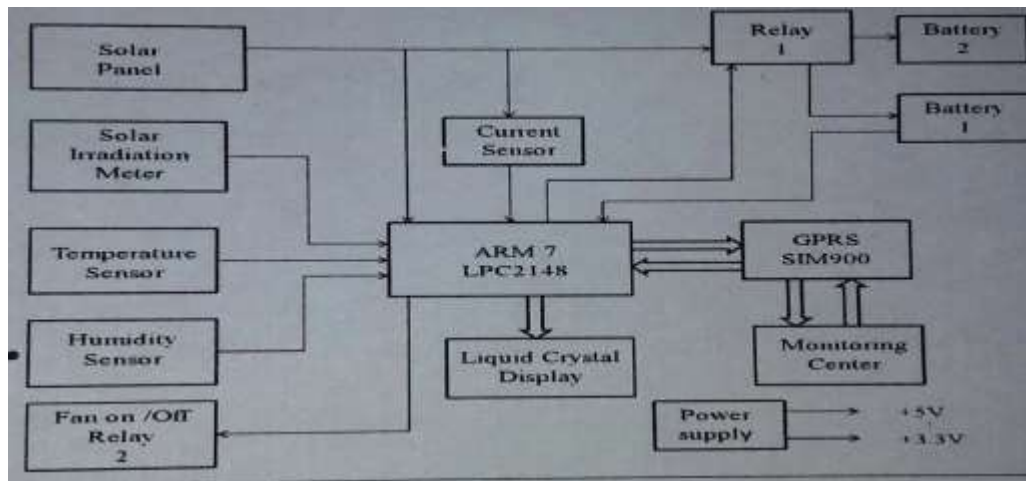

Fig.1 block diagram of solar power monitoring system

A. The Embedded Processor LPC2148 Arm7.:

The LPC2148 microcontrollers are based on a 32/16 bit ARM7TDMI-S CPU with real-time emulation embedded trace support that combines the microcontroller with embedded high speed flash memory ranging from 32 kB to 51 kB. A 128-bit wide memory interface and unique accelerator architecture enable 32-bit code execution at the maximum clock rate. A blend of serial communications interfaces ranging from a USB 2.0 Full Speed device, multiple UARTs, SPI, SSP to I2Cs, and on-chip SRAM of 8KB up to 40KB, make these devices very well suited for communication also have low power consumption.

B. Temperature Sensor:

The LM35 series are precision integrated-circuit temperature sensors, whose output voltage is linearly proportional to the Celsius (Centigrade) temperature (+ 10.0 mV/°C scale factor). It has an advantage over linear temperature sensors calibrated in° Kelvin, as the user is not required to subtract a large constant voltage from its output to obtain convenient Centigrade scaling. It operates from 4 to 20 volts. It provides Low output impedance. The LM35 is rated to operate over at -55° to +150°C temperature range.

C. Solar Irradiation Sensor –LDR

LDR is an input sensor which converts brightness (light) to resistance. It is made from cadmium sulphide (CdS) and the resistance decreases as the brightness of light falling on the LDR increases. Normally the resistance of an LDR is very high, sometimes as high as 1000000 ohms, but when they are illuminated with light resistance drops dramatically. It also is capable of reacting to a broad range of frequencies (Infrared (IR), visible light and ultraviolet (UV)).

D. Humidity Sensor (SY-HS 230)

SY-HS230 is resistance type Humidity Sensor Module. It operated on DC 5V. This sensor has operating temperature range 0~60°C (32~140°F) and Operating Humidity 95%RH or less 4. Its Humidity output 0~3.3V.

E. Current Sensor (ACS 712)

ACS712 current sensor can measure positive and negative currents (range -5A...5A). Its output voltage is proportional to current flowing between IP+ AND IP-. It requires +5V power supply.

IV. Software Design

The software implementation of this system can be divided in to two main parts. At transmitter side the software implementation is done on LPC2148 ARM7 processor. The software used for the ARM7 processor is Keil software (μ vision4). The whole programming at transmitter side is written in Embedded C language. At receiver side, software implementation is based on VB6.0 and the received data is saved in SQL database.

V. CONCLUSION

The solar power monitoring system could realize the accurate diagnosis and prevent faults from further expanding and improve reliability of photovoltaic power station.

VI. ACKNOWLEDGMENT

We would like to thank Raajdhani Engineering College, Bhubaneswar for motivating us to do research and development works on Arduino based Embedded system. We are thankful to the Faculty members of EE & EEE department for their support.

REFERENCES

- [1] Solar Power Wireless Monitoring Based On Embedded System, ISSN 2348 – 7968 ,IJISSET
- [2] Solar power wireless monitoring based on arm7 <http://ieeexplore.ieee.org/978-1-4577-0536-6/11>
- [3] GPRS networks by geoff sanders, lionel thorens, manfred reisky, oliver rulik and stefan deylitz.
- [4] Embedded systems by Rajkamal
- [5] Solar Power Systems Web Monitoring The 2nd symposium on renewable energy technology (soret), october2011, raiwai, Fiji <http://arxiv.org/ftp/arxiv/papers/1111/1111.1605.pdf>
- [6] Electronic Devices and circuits by A.P.Gadse&U.A.Bhakshi
- [7] Data Acquisition System For Performance Monitoring Of Solar Photovoltaic (Pv) Power Generation vol. 1 issue 7, september – 2012 www.ijert.org.
- [8] www.infocenter.arm.com/help/index.jsp?topic=/co_m.ar_m.doc.dai0234a/index.
- [9] www.ieee.org
- [10] www.google.com.

