

FIELD ORIENTED CONTROL OF INDUCTION MOTOR USING SVPWM

K.A Dange¹, A.S Inchure², R.B Gaikwad³, T.L Deshpande⁴. Department of Electrical Engineering,
S.N Gudadhe⁵ Ass Prof. Department of Electrical Engineering,
JSPM's Bhivarabai Sawant Institute of Technology And Research Wagholi Pune 412207

Abstract: Space Vector PWM (SVPWM) is a more sophisticated technique for generating a fundamental sine wave that provides a higher voltage to the motor and lower total harmonic distortion (THD). It is also compatible for use in vector control (Field orientation) of AC motors. This abstract describes the theory of SVPWM and the project shall be made using a programmed microcontroller of 8051 families duly interfaced to 3 phase six pulse inverter with 6 no's MOSFET from DC derived from a single phase mains or 3 phase, 50 Hz supply. The load shall be a three phase 50 Hz 440volt 0.5 HP motor. Alternatively, a star lamp load can be used in place of motor to view the waveform only.

Further this project can be enhanced by using IGBT instead of MOSFET for higher voltage power operations. Speed control of the motor can also be achieved by V/F method.

Key Words: SVPWM –Space Vector Pulse Width Modulation, AC- Alternating current, PWM-Pulse width modulation SVM- Space vector modulation,

I. INTRODUCTION:

SVM is an algorithm for the control of pulse width modulation (PWM). It is used for the creation of alternating current (AC) waveforms; most commonly to drive 3 phase AC powered motors at varying speeds from DC using multiple class D amplifiers. There are various variations of SVM that result in different quality and computational requirements. One active area of development is in the reduction of total harmonic distortion created by the rapid switching inherent to these algorithms. Space vector modulation is a PWM control algorithm for multiphase AC generation, in which the reference signal is sampled regularly, after each sample, nonzero active switching vectors adjacent to the reference vector and one or more of the zero switching vectors are selected for the appropriate fraction of the sampling period in order to synthesize the reference vector and one or more of the zero switching vector are selected for the appropriate fraction of sampling period in order to synthesize the reference signal as the average of the used vector.

II. CONSTRUCTIONAL DETAILS:

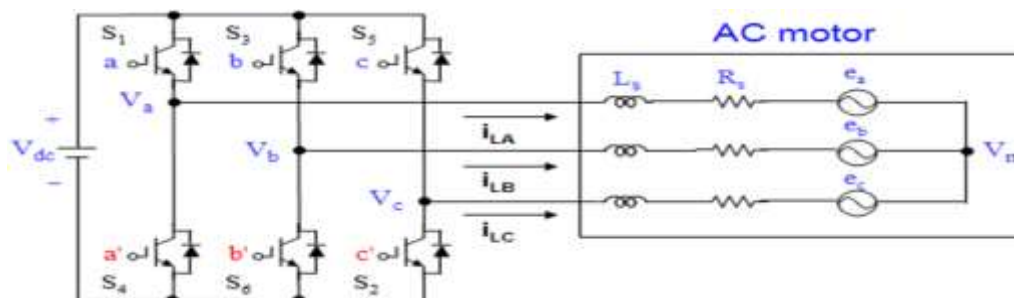

Fig 1: Output Voltages of Three-Phase Inverter

Where, Upper transistors: S_1, S_3, S_5

Lower transistors: S_4, S_6, S_2

Switching variable vector: a, b, c

S₁ through S₆ are the six power transistors that shape the output voltage

When an upper switch is turned on (i.e., a, b or c is “1”), the corresponding lower switch is turned off (i.e., a', b' or c' is “0”)

Eight possible combinations of on and off patterns for the three upper transistors (S₁, S₃, S₅)

Line to line voltage vector [V_{ab} V_{bc} V_{ca}]^t

$$\begin{bmatrix} V_{ab} \\ V_{bc} \\ V_{ca} \end{bmatrix} = V_{dc} \times \begin{bmatrix} 1 & -1 & 0 \\ 0 & 1 & -1 \\ -1 & 0 & 1 \end{bmatrix} \times \begin{bmatrix} a \\ b \\ c \end{bmatrix} \text{ Where switching variable vector } [a \ b \ c]^t$$

Line to neutral (phase) voltage vector [V_{an} V_{bn} V_{cn}]^t

$$\begin{bmatrix} V_{an} \\ V_{bn} \\ V_{cn} \end{bmatrix} = \frac{1}{3} V_{dc} \begin{bmatrix} 2 & -1 & -1 \\ -1 & 2 & -1 \\ -1 & -1 & 2 \end{bmatrix} \begin{bmatrix} a \\ b \\ c \end{bmatrix}$$

The eight inverter voltage vectors (V₀ to V₇)

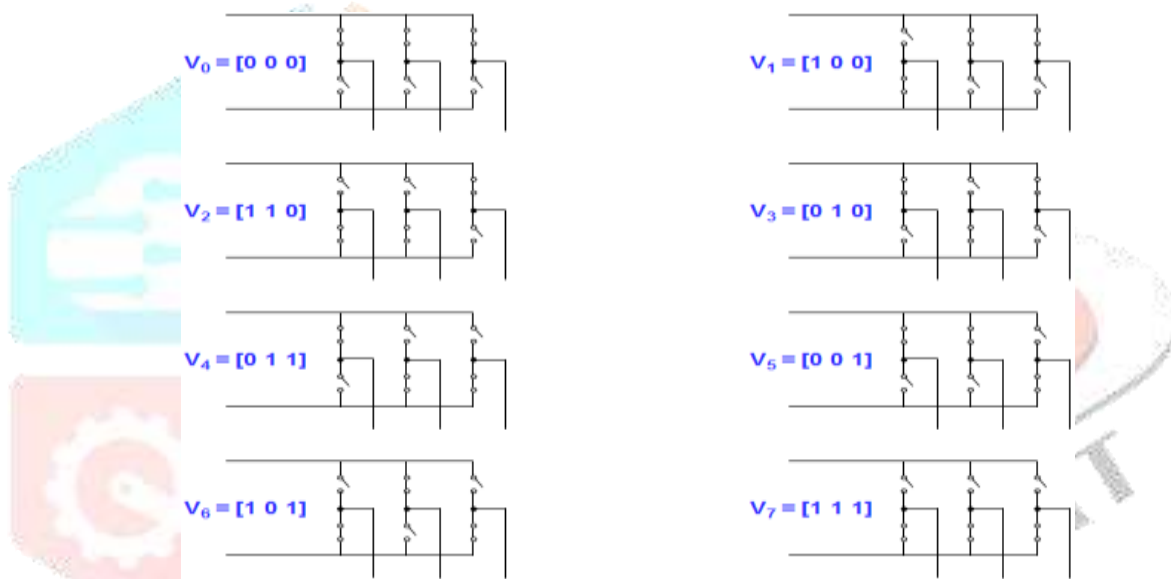

Fig 2: The eight combinations, phase voltages and output line to line voltages

Voltage Vectors	Switching Vectors			Line to neutral voltage			Line to line voltage		
	a	b	c	V _{an}	V _{bn}	V _{cn}	V _{ab}	V _{bc}	V _{ca}
V ₀	0	0	0	0	0	0	0	0	0
V ₁	1	0	0	2/3	-1/3	-1/3	1	0	-1
V ₂	1	1	0	1/3	1/3	-2/3	0	1	-1
V ₃	0	1	0	-1/3	2/3	-1/3	-1	1	0
V ₄	0	1	1	-2/3	1/3	1/3	-1	0	1
V ₅	0	0	1	-1/3	-1/3	2/3	0	-1	1
V ₆	1	0	1	1/3	-2/3	1/3	1	-1	0
V ₇	1	1	1	0	0	0	0	0	0

(Note that the respective voltage should be multiplied by V_{dc}.)

PRINCIPLE OF SPACE VECTOR PWM:

Treats the sinusoidal voltage as a constant amplitude vector rotating at constant frequency

This PWM technique approximates the reference voltage V_{ref} by a combination of the eight switching patterns (V₀ to V₇)

Co-ordinate Transformation (abc reference frame to the stationary d-q frame): A three-phase voltage vector is transformed into a vector in the stationary d-q coordinate frame which represents the spatial vector sum of the three-phase voltage

The vectors (V_1 to V_6) divide the plane into six sectors (each sector: 60 degrees)

V_{ref} is generated by two adjacent non-zero vectors and two zero vectors

COMPARISON OF SINE PWM AND SPACE VECTOR PWM:

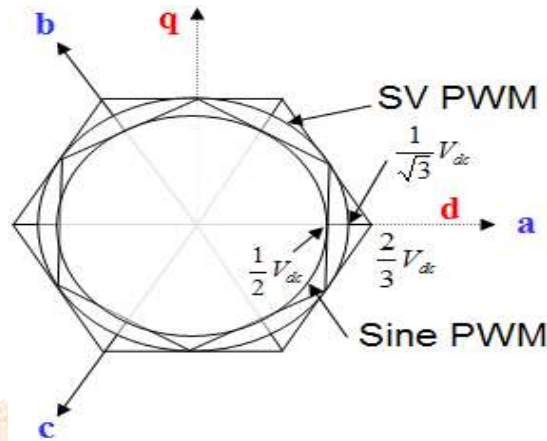

Fig: Locus comparison of maximum linear control voltage in Sine PWM and SV PWM.

Space Vector PWM generates less harmonic distortion in the output voltage or currents in comparison with sine PWM

Space Vector PWM provides more efficient use of supply voltage in comparison with sine PWM

Sine PWM: Locus of the reference vector is the inside of a circle with radius of $\frac{1}{2} V_{dc}$

Space Vector PWM: Locus of the reference vector is the inside of a circle with radius.

∴ Voltage Utilization: Space Vector PWM = $\frac{2}{\sqrt{3}}$ times of Sine PWM of $\frac{1}{\sqrt{3}} V_{dc}$

REALIZATION OF SPACE VECTOR PWM:

- Step 1. Determine V_d , V_q , V_{ref} , and angle (α)
- Step 2. Determine time duration T_1 , T_2 , T_0
- Step 3. Determine the switching time of each transistor (S_1 to S_6)

Step 1. Determine V_d , V_q , V_{ref} , and angle (α)

Coordinate transformation: abc to dq

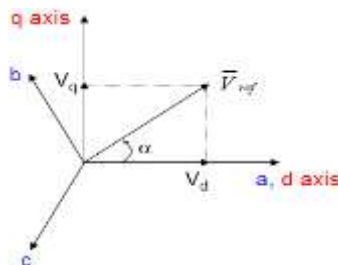

Fig: Voltage Space Vector and its components in (d, q)

Step 2. Determine time duration T_1, T_2, T_0 :

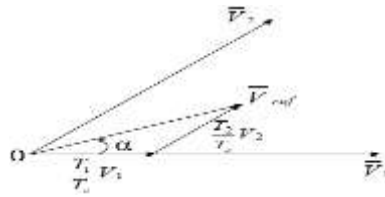

Fig: Reference vector as a combination of adjacent vectors at sector 1.

Switching time duration at Sector 1:

$$\int_0^{T_z} \bar{V}_{ref} dt = \int_0^{T_1} V_1 dt + \int_{T_1}^{T_1+T_2} V_2 dt + \int_{T_1+T_2}^{T_z} \bar{V}_0 dt \quad \dots\dots\dots (1)$$

$$T_z \cdot \bar{V}_{ref} = (T_1 \cdot \bar{V}_1 + T_2 \cdot \bar{V}_2)$$

$$T_z \cdot |\bar{V}_{ref}| \cdot \begin{bmatrix} \cos(a) \\ \sin(a) \end{bmatrix} = T_1 \cdot \frac{2}{3} \cdot \begin{bmatrix} 1 \\ 0 \end{bmatrix} + T_2 \cdot \frac{2}{3} \cdot V_{dc} \cdot \begin{bmatrix} \cos(\pi/3) \\ \sin(\pi/3) \end{bmatrix} \quad \dots\dots\dots (2)$$

(where, $0 \leq a \leq 60$)

$$T_1 = T_z \cdot a \cdot \frac{\sin(\frac{\pi}{3} - a)}{\sin(\pi/3)}$$

$$T_2 = T_z \cdot a \cdot \frac{\sin(a)}{\sin(\pi/3)}$$

$$T_0 = T_z - (T_1 + T_2), \left[\text{where, } T_z = \frac{1}{F_s} \text{ and } a = \frac{|\bar{V}_{ref}|}{\frac{2}{3}V_{dc}} \right] \dots\dots\dots (3)$$

Switching time duration at any Sector:

$$T_1 = \frac{\sqrt{3} \cdot T_z \cdot |\bar{V}_{ref}|}{V_{dc}} \left(\sin \left(\frac{\pi}{3} - \alpha + \frac{n-1}{3} \pi \right) \right) \quad \dots\dots\dots (4)$$

$$= \frac{\sqrt{3} \cdot T_z \cdot |\bar{V}_{ref}|}{V_{dc}} \left(\sin \frac{n}{3} \pi - \alpha \right)$$

$$= \frac{\sqrt{3} \cdot T_z \cdot |\bar{V}_{ref}|}{V_{dc}} \left(\sin \frac{n}{3} \pi \cos \alpha - \cos \frac{n}{3} \pi \sin \alpha \right)$$

$$T_2 = \frac{\sqrt{3} \cdot T_z \cdot |\bar{V}_{ref}|}{V_{dc}} \left(\sin \left(\alpha - \frac{n-1}{3} \pi \right) \right) \quad \dots\dots\dots (5)$$

$$= \frac{\sqrt{3} \cdot T_z \cdot |\bar{V}_{ref}|}{V_{dc}} \left(-\cos \alpha \cdot \sin \frac{n-1}{3} \pi + \sin \alpha \cos \frac{n-1}{3} \pi \right)$$

DETERMINE THE SWITCHING TIME OF EACH TRANSISTOR (S₁ TO S₆):

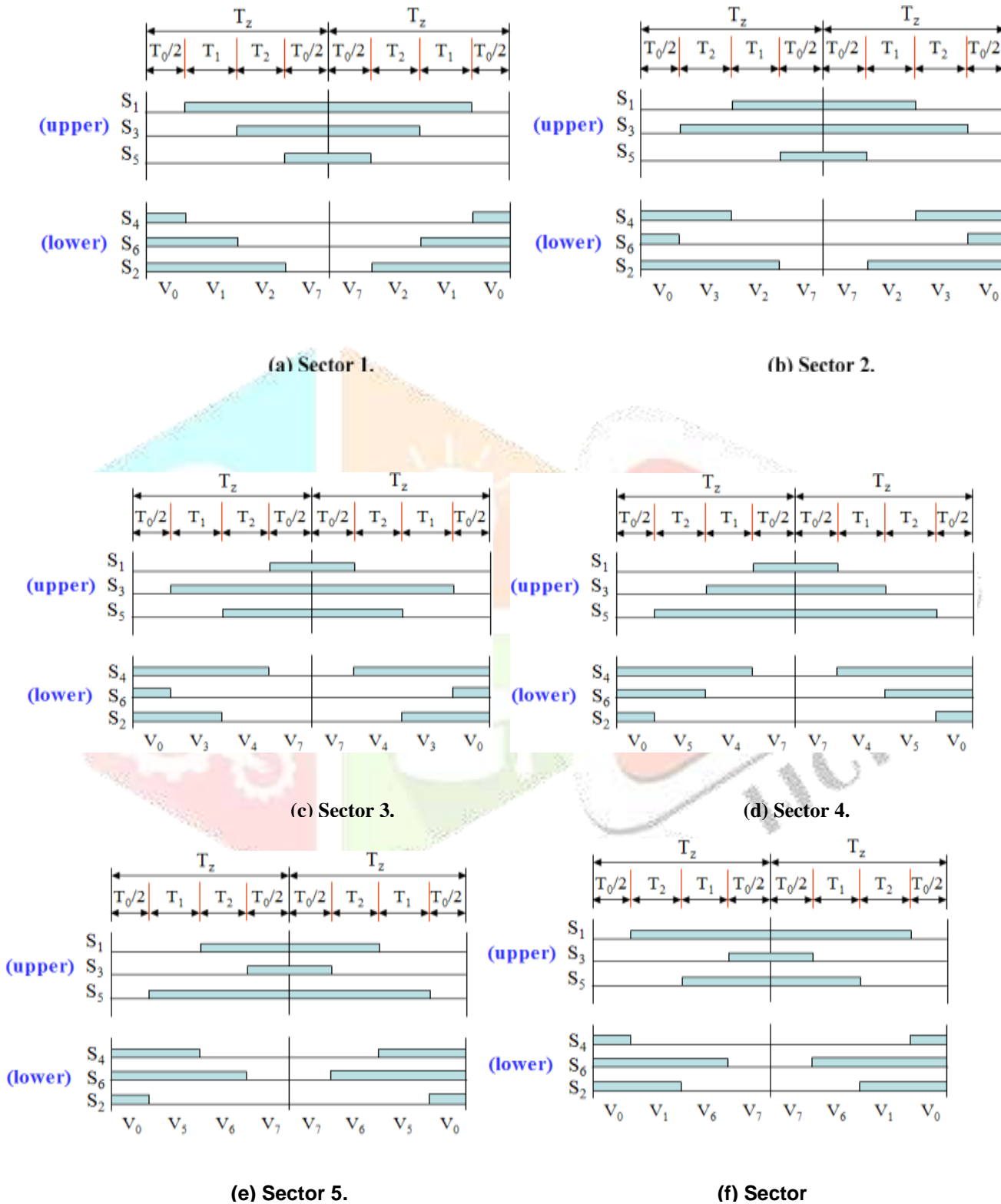

Fig: Vector Pwm Switching Patterns At Each Sector

SECTOR	UPPER SWITCHES (S_1, S_2, S_3)	Low switches (S_1, S_2, S_3)
1	$S_1 = T_1 + T_2 + T_0/2$ $S_3 = T_2 + T_0/2$ $S_5 = T_0/2$	$S_4 = T_0/2$ $S_6 = T_1 + T_0/2$ $S_2 = T_1 + T_2 + T_0/2$
2	$S_1 = T_1 + T_0/2$ $S_3 = T_1 + T_2 + T_0/2$ $S_5 = T_0/2$	$S_4 = T_2 + T_0/2$ $S_6 = T_0/2$ $S_2 = T_1 + T_2 + T_0/2$
3	$S_1 = T_0/2$ $S_3 = T_1 + T_2 + T_0/2$ $S_5 = T_2 + T_0/2$	$S_4 = T_1 + T_2 + T_0/2$ $S_6 = T_0/2$ $S_2 = T_1 + T_0/2$
4	$S_1 = T_0/2$ $S_3 = T_1 + T_0/2$ $S_5 = T_1 + T_2 + T_0/2$	$S_4 = T_1 + T_2 + T_0/2$ $S_6 = T_2 + T_0/2$ $S_2 = T_0/2$
5	$S_1 = T_1 + T_0/2$ $S_3 = T_0/2$ $S_5 = T_1 + T_2 + T_0/2$	$S_4 = T_1 + T_0/2$ $S_6 = T_1 + T_2 + T_0/2$ $S_2 = T_0/2$
6	$S_1 = T_1 + T_2 + T_0/2$ $S_3 = T_0/2$ $S_5 = T_1 + T_0/2$	$S_4 = T_0/2$ $S_6 = T_1 + T_2 + T_0/2$ $S_2 = T_2 + T_0/2$

Table 2. switching time table at each sector

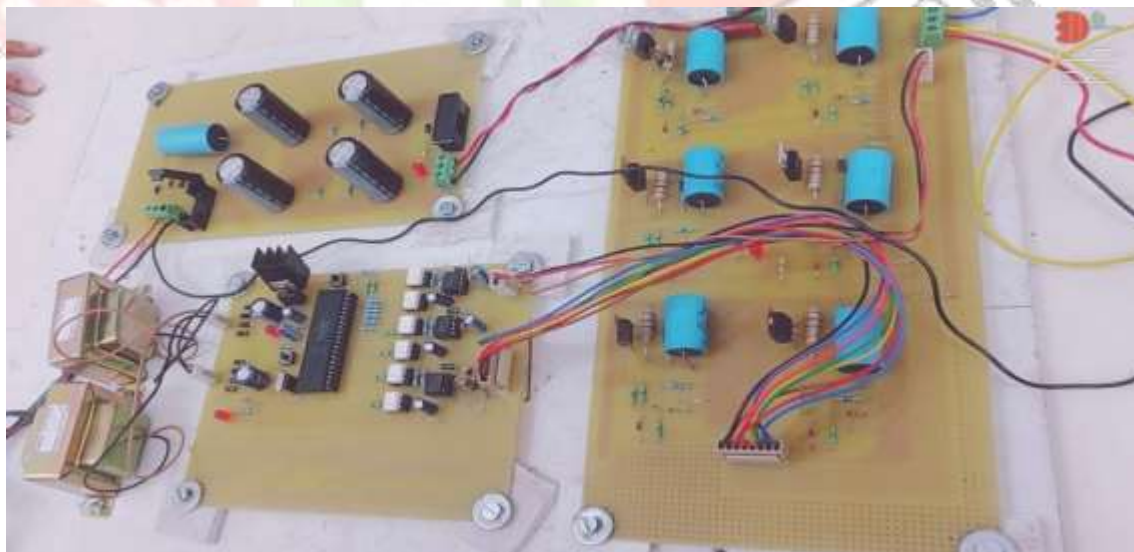

Fig. Final Assembly of Circuits

III. ADVANTAGES:

- 1) SVM lower harmonics and a higher modulation.
- 2) Better fundamental output voltage and current.
- 3) Reduce switching losses.
- 4) High switching frequency

IV. RESULT:

Sinusoidal PWM three phase reference modulating signals are compared against a common triangular carrier to generate the PWM signals for the three phases. It is simple and linear between 0% and 78.5% of six step voltage values, which results in poor voltage utilization. Frequency in conventional spwm output waves owing to their fixed switching frequencies.

The simulation circuit connection of a three phase inverter based induction motor drive with Sinusoidal PWM (SPWM) is as shown in above figure. Here the three-phase 415V, 50Hz ac supply is converted into dc and then this DC voltage is converted into 3phase variable frequency ac. Here the controlling of inverter is done by PWM method i.e. sinusoidal PWM. The speed and electromagnetic responses of induction motor with the different load torques at different instants are as shown in Fig. 11. From this figure it is observed that when load is applied on the motor the speed of motor get reduced.

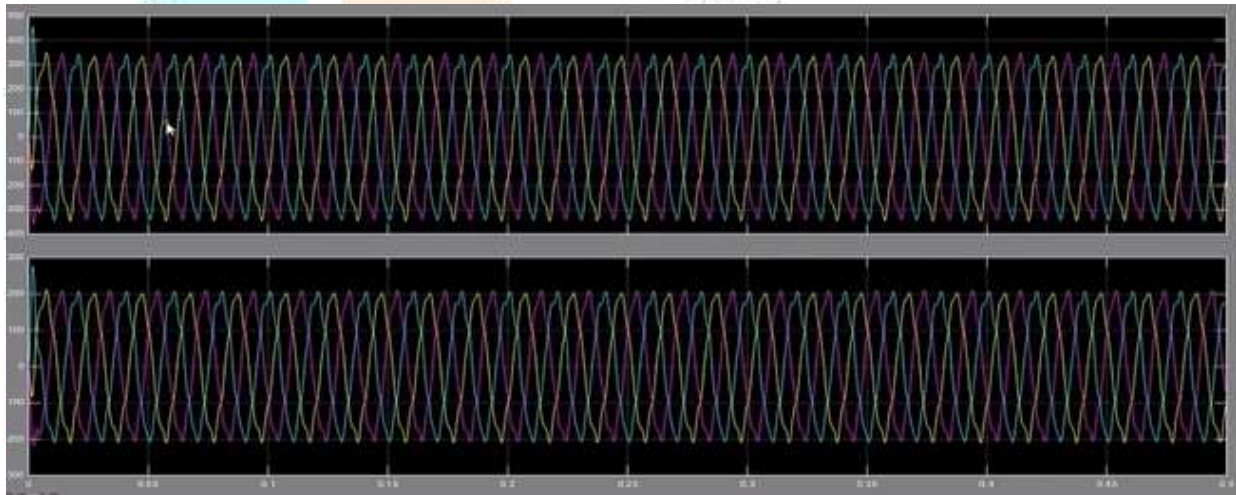
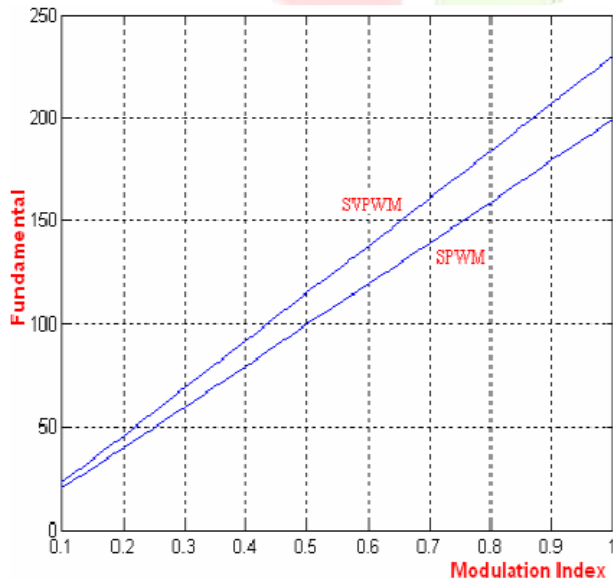

Fig. output waveform



Fundamental voltage comparison of SVPWM & SPWM

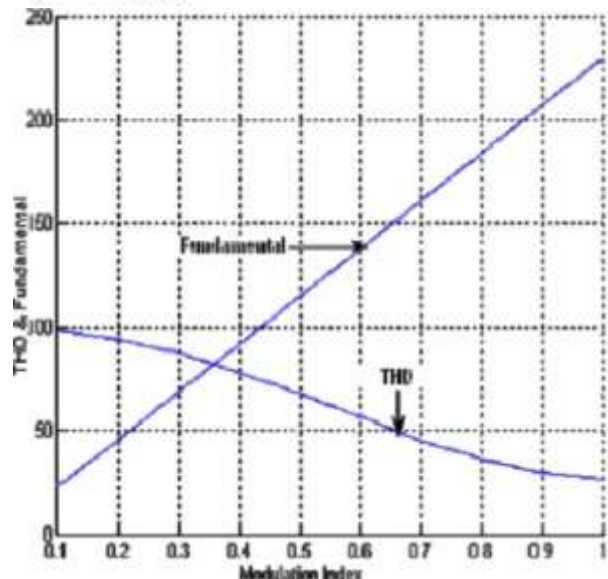

Fig. Fundamental & THD Vs Modulation Index (m)

Fig.

V. FUTURE SCOPE:

The space vector pulse width modulation based algorithms for multilevel inverters. The SVPWM algorithms have essentially been aimed at reducing the harmonic distortion in the output voltage of multilevel inverters. The performance of all these algorithms can be evaluated in the over modulation zone. Analytical evaluation of harmonic distortion for multilevel inverters can also be carried out.

More SVPWM based techniques can be developed for inverter switching at much higher frequencies and hardware implementation can also be done. All the proposed algorithms in this thesis are for time-invariant systems. Further to reduce the switching losses of the inverters, discontinuous pulse width modulation algorithms have to be proposed

VI. CONCLUSION:

The simulation of “Control of Induction Motor Drive Using Space Vector PWM” is carried out in MATLAB/Simulink. The simulation has been done for open loop as well as closed control. The appropriately output results are obtained. The variation of speed of Induction Motor has been observed by varying the load torque in open loop control and results are noted down in the table. Also observed that for the change in input speed operate the motor speed is settled down to its final value with in 0.1sec.

VII. REFERENCES:

- [1] Vas, P., “Electrical Machines and Drives a Space—Vector Theory Approach,” Oxford University Press, 1992.
- [2] Rashid, M. H, “Power Electronics Handbook,” Academic Press, 2001.
- [3] Design and Implementation of Space Vector Pwm Inverterbased Microcontroller; Mahmoud M. Gaballah.
- [4] control of induction motor drive using space vector PWM by Syed Mahamood & Arshia azam
- [5] Electrical motor drives by R. KRISHNAN

