

# PV-BATTERY-BASED HYBRID MICROGRIDS WITH ELECTRIC VEHICLE USING UNIFIED CONTROL AND POWER MANAGEMENT SCHEME

<sup>1</sup>K.Swapna Rani, <sup>2</sup>V.Sandhya Rani, <sup>3</sup>M.Jhansi Rani, <sup>4</sup>M.Lingesh

<sup>1,2,3</sup>Assistant Professor, <sup>4</sup>UG Student, <sup>1,2,3,4</sup>Department of Electrical and Electronics Engineering, Visvesvaraya College of Engineering & Technology, Hyderabad, India.

## ABSTRACT

A power grid reinforcement management system to efficiently handle a photovoltaic (PV) powered automobile is described in this research. To boost acceleration, electrical grading reconstruction techniques (EAR, horizontal, range, and horizontal-series) are utilized and maintained according to driving conditions (the early movement state, speed state, and fast state). Because the horizontal approach produces a lot of voltage and torque, the speed is employed to keep things moving. When both speed and torque are necessary, the horizontal-range approach is utilized at the quickest speed after the automobile begins. A photovoltaic-based automobile with a 2.65 m solar cell has been set up for an efficient test, with a variety of motor beginning torque results producing 1.4 times the torque comparable to the parallel-range type 2.5 times the series title. So the horizontal array of reconfiguration type is suitable for starting the car. When testing the maximum speed of the motor, the range of results range is twice the motor speed of the horizontal-range type, and 4.1 times higher than the horizontal. So the range of the series is suitable for a car at high speeds. In this method a motor acceleration in the photovoltaic-based car revealed results of better than 38 percent compared to a range of sequences.

**Index Terms**—Solar PV System, Battery, Control and Power Management System, Distributed Energy Resource, Microgrid, Power Electronics, Electrical vehicle.

## INTRODUCTION

The ever-increasing need for energy, along with worries about environmental degradation, has prompted electric power specialists to seek for sustainable methods of power generation. Distributed generation (DG) in the form of renewable resources, such as solar energy, is seen to be an efficient option for reducing reliance on traditional power generation and improving power system dependability and quality [1]. Because of their appealing properties such as an availability of sunshine and clean energy, photovoltaic (PV) power systems have emerged as one of the most promising renewable generation technologies. Rapid PV technology development and falling installation costs are also driving more PV use in power systems. However, due to the nature of solar energy and PV panels, instantaneous power output of a PV system depends largely on its operating environment, such as solar irradiance and surrounding temperature, resulting in constant fluctuations in the output power [2], [3]. Therefore, to maintain a reliable output power, battery storage systems are usually integrated with PV systems to address the variability issue.

A typical configuration of PV-battery system is illustrated in Fig. 1, which is a hybrid microgrid system consisting of a PV array that contains a number of PV panels, battery bank for power storage, and a centralized bidirectional inverter that interfaces the DC to AC power system [4], [5]. A unidirectional DC/DC converter is installed to control the power of PV arrays, while the battery bank is charged/ discharged by controlling a bidirectional converter that bridges the battery and the DC bus. DC loads are supplied through direct connection to the DC bus and AC loads and the point of common coupling (PCC) is located on the AC side. Before connecting to the utility grid, a transformer is employed to step up the AC voltage to that of the grid. The PV-battery system can be working in either grid-connected or islanded modes by changing the breaker status at the PCC, subject to the condition of the system and the grid, e.g., a serious fault on the AC bus may require opening the breaker to prevent the back-feeding current from the grid [6]. Since PV output power and load demand may change constantly during a day, the power management algorithms for PV-battery system are required to manage the power flow and promptly respond to any change to maintain the balance between power productions and consumptions. Furthermore, both DC bus and AC bus voltages must be stabilized regardless of changes in the system to ensure a reliable power supply.

A number of power management methods for PV-battery systems have been proposed in the literature. An energy management and control system is introduced in [7] which provide stable operation for a wind-PV-battery system. The control algorithm is designed for single-phase inverter and it is not able to control the reactive power. Ref. [8] introduces another control method for a wind-PV-battery system, which focuses on optimizing the sizes and costs of the PV array and battery instead of dynamic power balancing. Moreover, the proposed method requires massive historical data of 30 years to estimate the power generated by the wind turbine and PV array. Similarly, in [9], a method to optimize the wind-PV battery system is proposed. Both [8] and [9] focus on size optimization instead of detailed control methods for individual power source. A power management strategy for a PV-battery unit is discussed in [10] based on droop control for load sharing between the PV-battery unit and another power source. An improved version, which considers multiple power units, has been presented in Ref. [11]. Although these strategies successfully manage the power demand and production, both of them mainly focus on the power management between the PV- battery unit and other generation units. Additionally, these methods do not consider systems with DC bus and loads. A hierarchical control algorithm for a PV-battery-hydropower

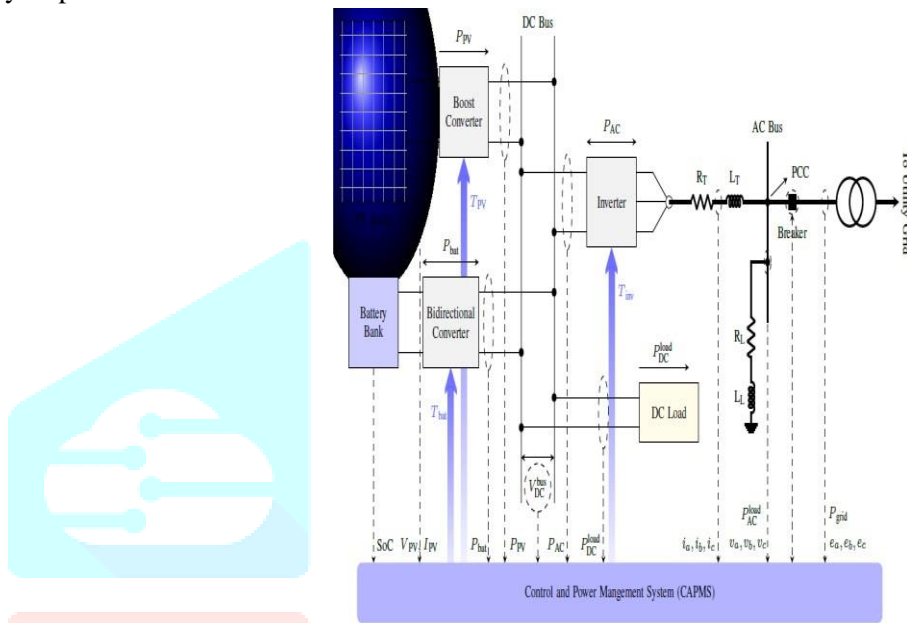

Fig. 1. The proposed control and power management system (CAPMS) for PV-battery-based hybrid microgrids.

system in [12] regulates the AC bus voltage by the hydropower generator and manage the active and reactive power by the PV-battery unit, and Ref. [13] introduces a similar method for a hybrid PV-battery- diesel system. However, both these algorithms fail to consider the voltage control for the case where the hydropower or diesel generator is out of service. A decentralized method for an islanded PV-battery system is presented in [14]. This method aims at solving load sharing in system configurations with multiple PV and battery units. Ref. [15] introduces a similar method which only aims at singlephase low voltage islanded microgrids. None of the aforementioned methods considers the grid- connected situation, where there is power exchange between the hybrid system and the utility grid. Ref.

[16] introduces a supervisory control system based on 24-hour forecasted data for a grid-connected wind- PV-battery system. The topology of the studied system, where PV and battery bank are interfaced with the grid using decentralized inverters, is different from the system configuration of this study. Similar methods using day ahead data for power prediction of a PV-battery system are proposed in

[17] and m[18], which are based on dynamicprogramming and neural networks, respectively. Ref.

[19] proposes a mathematical

model for controlling battery storage in PV systems. All these four methods mainly focus on forecasting the power generation and demand, and scheduling the power flow of PV or battery, instead of specific control algorithms. Additionally, there are also workstrying to manage the power more effectively

by using new topologies of converters [20]–[22] instead of modifying controlling methods. None of the works in the reviewed literature takes into account the stabilization of the DC bus voltage, which is of great importance for reliable power supply for DC loads.

In an attempt to address the issues discussed above, this paper proposes a control and power management system (CAPMS) for PV-battery systems, which is a centralized control

system that flexibly and effectively controls power flows among the power sources, loads, and utility grid. The proposed method succeeds in regulating the voltage on both DC and AC buses, transferring between grid-connected and islanded operating modes smoothly, and balancing power quickly in the hybrid PV-battery system.

### PHOTOVOLTAIC INVERTER

The PV power generation system consists of following major blocks:

1. PV unit
2. Inverter
3. Grid
4. MPPT

Analytical models are essential in the dynamic performance, robustness, and stability analysis of different control strategies. To investigate these features on a three-phase grid-connected PV system, the mathematical model of the system needs to be derived. The modeling of the proposed system includes:

1. Photovoltaic Cell and PV array Modeling
2. Three-phase inverter model
3. Three-phase fundamental transformations modeling

In this chapter, the operation and role of each of these components will be described and their mathematical model will be derived.

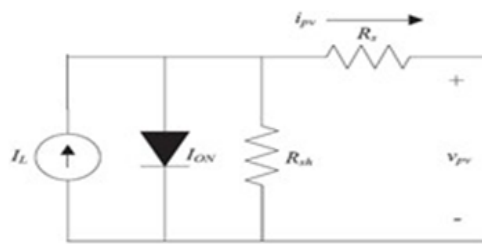

**Fig.2** Equivalent circuit diagram of the PV cell

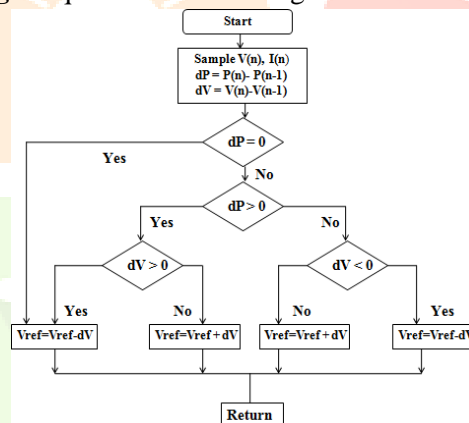

**Fig.3** Flow chart of perturb and observe

### DC-DC Converter Basics

A DC-to-DC converter is a gadget that acknowledges a DC info voltage and produces a DC yield voltage. Normally the yield delivered is at an alternate voltage level than the info. Also, DC-to-DC converters are utilized to give clamor confinement, force transport regulation, and so on. This is a synopsis of a portion of the prevalent DC-to-DC converter topologies.

### MPPT: (Maximum Power Point Tracking)

The P&O algorithm requires few mathematical calculations which makes the implementation of this algorithm fairly simple compared to other techniques. For this reason, P&O method is heavily used in renewable energy systems.

### Perturb and Observe algorithm

At present, the most popular MPPT method in the PV systems is perturb and observe. In this method, a small perturbation is injected to the system and if the output power increases, a perturbation with the same direction will be injected to the system and if the output power decreases, the next injected perturbation will be in the opposite direction. The Perturb and observe algorithm operates by periodically perturbing (i.e. incrementing or decrementing) the array terminal voltage and comparing the PV output power with that of the previous perturbation cycle.

If the PV array operating voltage changes and power increases, the control system moves the PV array operating point in that direction, otherwise the operating point is moved in the opposite direction.

In the next perturbation cycle, the algorithm continues in the same way. The logic of algorithm is shown in Fig.2.2. A common problem in perturb and observe algorithm is that the array terminal voltage is perturbed every MPPT cycle, therefore when the maximum power point is reached, the output power oscillates around the maximum power point resulting in power loss in the PV system.

### BUCK CONVERTER

In this circuit the transistor turning ON will put voltage  $V_{in}$  toward one side of the inductor. This voltage will tend to bring about the inductor current to rise. At the point when the transistor is OFF, the present will keep coursing through the inductor however now moving through the diode.

We at first accept that the current through the inductor does not achieve zero, in this way the voltage at  $V_x$  will now be just the voltage over the leading diode amid the full OFF time. The normal voltage at  $V_x$  will rely on upon the normal ON time of the transistor gave the inductor current is persistent.

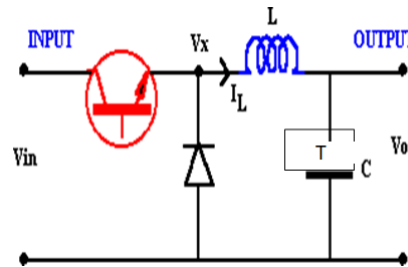

Fig 4 Buck Converter

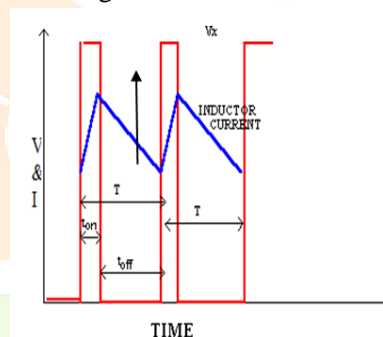

Fig 5: Voltage and current changes

### THE PROPOSED CONTROL AND POWERMANAGEMENT SYSTEM

The proposed CAPMS is a centralized power management system consisting of a supervisory module that monitors the required real-time parameters (dashed lines in Fig. 1) from the PV-battery system and multiple controllers for each of the power converters. According to the situation of the monitored parameters, CAPMS decides the scenarios and select specific control schemes to be applied to the converters to ensure a reliably power environment. Although the proposed CAPMS is designed based on the PV-battery system configuration shown in Fig. 1, for other configurations, such as systems with decentralized inverters or multiple battery banks, similar approach may be applicable with proper modifications. Detailed schemes of the CAPMS, taking into account both grid-connected and islanded modes, are depicted in Fig. 2, which indicates the possible operating scenarios of the PV-battery microgrid and how CAPMS responds to control and balance the system.

As presented in the flowcharts, the PV-battery system, which connects to the grid via a circuit breaker, can operate either in islanded or grid-connected mode, depending on the conditions and plans of both the microgrid and main grid. Firstly, the CAPMS monitors the status of circuit breaker and determines different voltage and power control schemes to be applied to corresponding converters or inverter. In particular, in grid-connected mode, the inverter controls the DC bus voltage ( $V_{bus DC}$ ) and reactive power (QAC) that is exchanged with the AC side; the PV converter controls the power output of the PV array (PPV); and the battery converter manages the charging or discharging of the battery bank. In islanded mode, where the breaker is open, CAPMS has to ensure the reliability of electric power supplied to the loads, i.e., DC and AC bus voltages and AC frequency have to be maintained around set points within acceptable limits, to prevent damaging the loads during transitions. Therefore, upon transferring from grid-connected to islanded mode, the inverter switches to regulate the AC bus voltage ( $v_a$ ,  $v_b$ , and  $v_c$ ) and frequency ( $f$ ), while  $V_{bus DC}$  is regulated by the battery converter. Secondly, state of charge (SoC) of the battery bank is always monitored in both modes. Therefore, CAPMS is

$$\text{Grid-connected: } P_{PV} + P_{bat} = P_{DC}^{load} + P_{AC}^{load} + P_{grid}, \quad (1)$$

$$\text{Islanded: } P_{PV} + P_{bat} = P_{DC}^{load} + P_{AC}^{load}, \quad (2)$$

aware of the available energy storage that can be used in the battery. The upper and lower limits of the SoC (SoCupper limit and SoClower limit) are set up to make sure the battery is not over-charged or discharged and to increase its cycle life [27]. Depending on the PV output power, SoC and power limit of the battery, DC and AC loads, and the grid demand, CAPMS decides the operation modes of the PV array (MPPT or power-reference mode) and the battery (charging or discharge mode) and provides proper reference values to the controllers, if applicable. Therefore, power flows in the hybrid microgrid are always balanced. The power management criteria are based on

where  $P_{PV}$  is the output power of the PV array,  $P_{bat}$  is the power flows in the battery converter ( $P_{bat} < 0$  in charging mode and  $P_{bat} > 0$  in discharging mode),  $P_{load DC}$  and  $P_{load AC}$  are DC and AC loads, respectively, and  $P_{grid}$  generally represents the power exchanging between the main grid and the microgrid through the breaker ( $P_{grid} < 0$  when receiving power and  $P_{grid} > 0$  when sending power). Note that the power demand

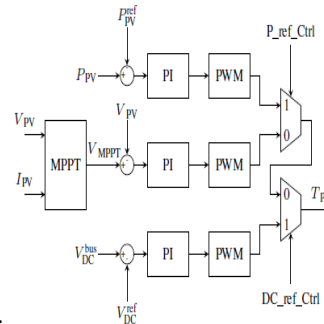

Fig. 2. PV array controller.

from the main grid is denoted as  $P_{demand grid}$  (Fig. 2), which might be obtained by forecasting data. Before switching from islanded to grid-connected mode, CAPMS will synchronize the AC voltages at the PCC of the microgrid to follow the grid-side voltages to ensure a smooth transition. With well-balanced power and regulated voltages, CAPMS ensures an uninterrupted power on both DC and AC buses

and allows loads to plug and play in the PV-battery system, regardless of disturbances from switching operating modes. Additionally, since the DC bus voltage is controlled, as long as voltage level matches, DC loads will be able to connect to the DC bus without additional converters. When necessary, the PV-battery system can also provide reactive power to the grid. Detailed controlling schemes for each part of the system will be elaborated in the next section.

## CONTROLLER DESIGN OF THE CAPMS

### PV Array Controller

The PV array converts solar energy into DC power, and is connected to the DC bus via a boost DC/DC converter. However, due to nonlinear characteristics of PV panels and the stochastic fluctuations of solar irradiance, there is always a maximum power point (MPP) for every specific operating situation of a PV array. Therefore, maximum power point tracking (MPPT) algorithms are typically implemented in PV system to extract the maximum power a PV array can provide [28]. The proposed CAPMS employs one of the most popular methods, the Incremental Conductance MPPT, which provides a reference voltage  $V_{MPPT}$  that the PV array will track to produce the maximum power under various operation conditions (different combinations of irradiance and temperature). There are three possible control schemes for the PV array: MPPT control, power-reference control, and DC bus voltage control, depending on the situation of the PV-battery system. For example, in islanded mode, when  $P_{MPPT PV}$  is greater than the total load demand (DC and AC), and the battery is fully charged or the charging rate  $P_{bat}$  reaches its upper limit, the CAPMS will generate control commands  $P_{ref Ctrl} = 1$  and  $DC_{ref Ctrl} = 0$  to set the PV array to work in power-reference control mode by sending PWM streams,  $T_{PV}$ , to the DC/DC

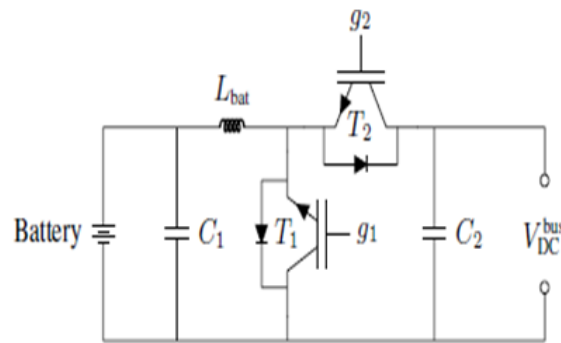

Fig. 3. Bidirectional DC/DC converter for the batterybank.

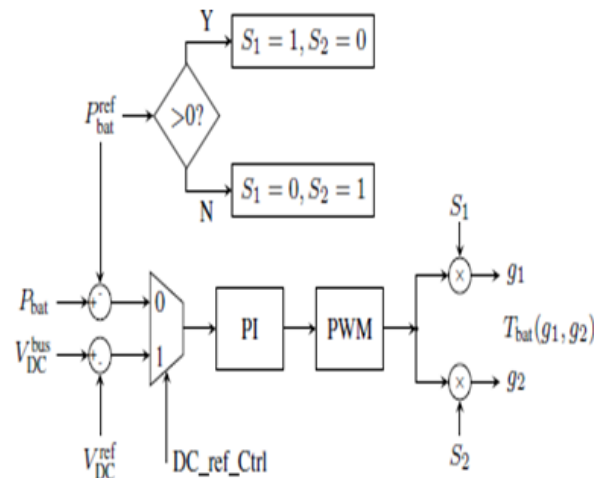

Fig. 4. Battery charging/discharging controller.

converter accordingly. In this case, to balance the power flows, CAPMS will decide proper power references for the PV array, Pref PV, according to the value of which the operating voltage of the PV array, VPV, will be moving between its VMPPT and the open-circuit voltage, VOC. Since the DC bus voltage is regulated by the battery converter in this situation, there will be a stable voltage at the DC bus in spite of the fluctuations in VPV. In MPPT mode (P ref Ctrl = 0 and DC ref Ctrl = 0), real-time PV current, IPV, and V PV are measured and sent to the MPPT module, which then provides V MPPT as the voltage reference for the PV array. Additionally, in islanded mode, when the battery is not available, e.g., due to faults, the PV converter has to switch to control the DC bus voltage to ensure a stable power supply to the loads on the DC bus (P ref Ctrl = 0 and DC ref Ctrl = 1). Fig. 3 illustrates the controller for these three modes. Note that the situation where both P ref Ctrl = 1 and DC ref Ctrl = 1 is not applicable.

### Battery Controller

As an energy buffer, battery bank is necessary in PV systems for power balancing. The battery bank of this system is connected to the DC bus and is controlled by a bidirectional DC/DC converter (Fig. 4) which includes two switches, T1 and T2, that control the charging/discharging process. Fig. 5 explains the detailed control process. In grid-connected mode, with the command DC ref Ctrl = 0, the converter controls the power flow (Pbat) in or out of the battery, where in discharging mode Pbat > 0, and in charging mode Pbat < 0. The final output of the battery controller is a two-dimensional switching signal Tbat(g1; g2). In Islanded mode, the control command DC ref Ctrl is set to -1 by the CAPMS, which switches the converter to work in voltage reference mode. The output voltage of converter, which is also the DC bus voltage, is regulated to follow the reference so that the DC load voltage is stabilized. The CAPMS monitors the SoC of the battery and enforces its upper and lower limits (SoCupper limit = 90% and SoClower limit = 10% in this study) in order to increase the life cycle. Note that the selections of the SoC limits do not affect the performance of the controller.

### Inverter Controller

A three-phase inverter is used to convert DC to AC power, interfacing the DC and AC sides. Similar to the converters discussed above, the control scheme of inverter depends on the operating (grid-connected or islanded) mode of the system. As is illustrated in Fig. 1 and 6, in grid-connected mode, a phase-locked loop (PLL block) is employed to extract  $\omega$ , angle of phase-A voltage after the breaker (ea). In islanded mode,  $\omega$  is generated locally, which is a periodical ramp signal

varying from 0 to  $2\pi$  with frequency  $f$ . It is used to decompose the three-phase AC bus voltages ( $v_a$ ;  $v_b$  and  $v_c$ ) and the inverter output currents ( $i_a$ ;  $i_b$  and  $i_c$ ) into d-q frame variables  $V_d$  and  $V_q$ , and  $I_d$  and  $I_q$  by Park transformation, respectively, for control purposes. Depending on the operating mode, the controller selects different sets of variables to be controlled. Under islanded mode, CAPMS sets the signal  $-Islanded$  to 1, forcing the converter to regulate the AC bus voltage  $V_d$  and  $V_q$ . Frequency of the AC bus voltages ( $f$ ) is set to 60 Hz in an openloop manner. Before closing the breaker and reconnecting the PV-battery system to the grid, the AC bus voltage must be synchronized with the grid. During islanded mode, the signal  $-Sync$  is set to 0 so that CAPMS has full control of the AC bus voltage by adjusting the references,  $V_{refd}$  and  $V_{refq}$ . However, to ensure a smooth transition upon switching to gridconnected mode,  $-Sync$  will be set to 1 to synchronize the AC bus and grid side voltages right before closing the breaker. To this end,  $\theta$  will be synchronized to follow the output angle of PLL, and the AC voltages after the breaker in d-q frame,  $E_d$  and  $E_q$ , will be chosen as the references for  $V_d$  and  $V_q$ .

**Simulation Results**

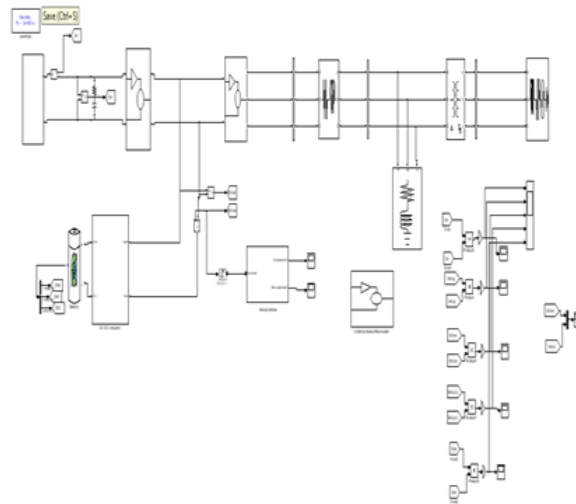

Fig . Complete Block Diagram Of grid connected Simulation

In order to verify the performance of the proposed Control And Power management Scheme, numerous simulation and experimental case studies are carried out in this section using the PSCAD/EMTDC and Matlab/Simulink software package and the dPACE-DS1104 platform. A PV-battery system is constructed with the configuration presented in Fig. 1, with the parameters listed in Table I. Note that the parameters for the PV array are under standard testing condition (STC, irradiance = 1000W/m<sup>2</sup>, temperature = 25\_C). The battery bank uses a general Ni-Cd characteristic model whose capacity is sized to support 5 days of autonomy operation (for 150kW loads) under low irradiance conditions. The proposed Control And Power Management Scheme monitors the required variables out of the PV-battery system mentioned in the above sections, process the data following the schemes in Fig. 2, and, according to the situation observed, switches the control schemes automatically. The case studies test the CAPMS's responses for multiple scenarios that the PV-battery system is working in or switching to. Results are analyzed individually in each case.

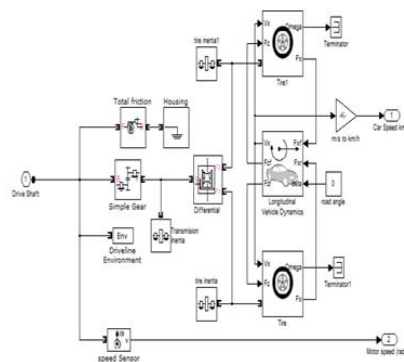
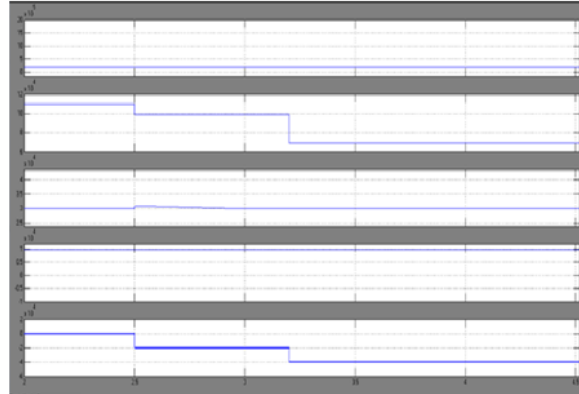

Fig.2 Electric car internal diagram

**Electric car**

The design of a electric car is strongly limited by the amount of energy introduced into the car. electric are built for eletric car racing and also for public use. List of prototypes of solar powered cars. Even the best solar cells can only collect limited power and energy on the surface of the car. This limits solar cars to ultralight composite bodies to save weight. Solar carsdo not have the safety and convenience features of conventional vehicles. The first solar family car was built in 2013 by students in the Netherlands. [2] This vehicle is capable of traveling 550 miles on a single charge during the day. It weighs 850 pounds and has a 1.5 kW solar generator. Solar vehicles must be light and efficient. Vehicles with 3,000 pounds or even 2,000 pounds are less practical. Stella Stella's predecessor, Stella Lux, broke a record with a 932- mile span. The Dutch are trying to commercialize thistechnology.

**Grid Connected ModeCase A-1**



Case A-1: (a) power flows and (b) voltage values of the PV-battery system.

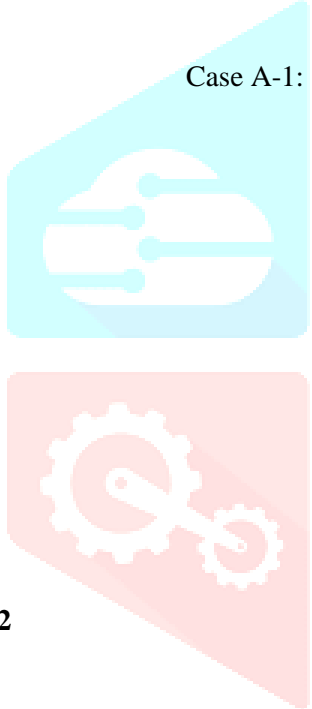

**Case A-2**

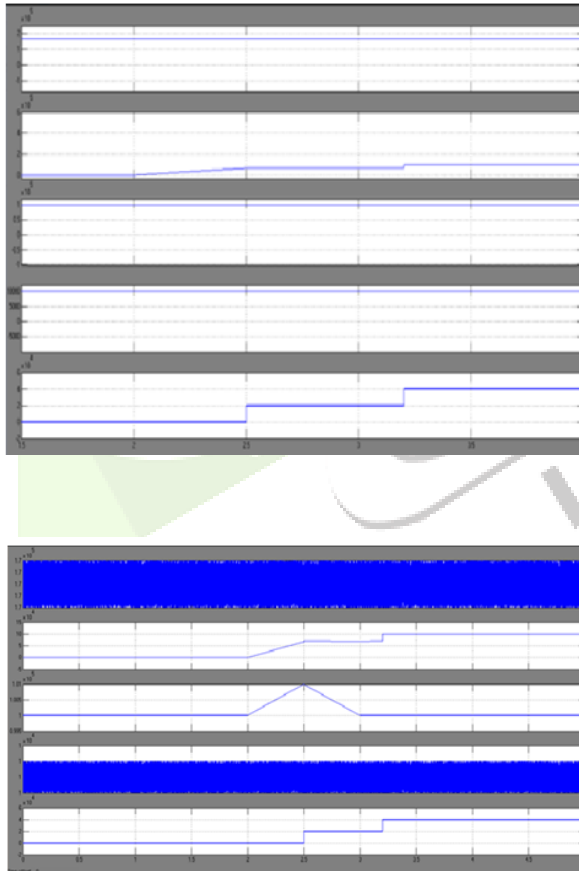

power flows of the PV-battery system.



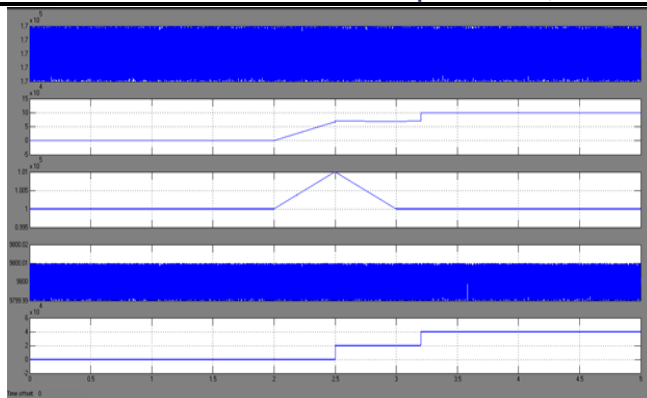

power flows and voltage changes in pv array at Pv-battery system. Islanded Mode

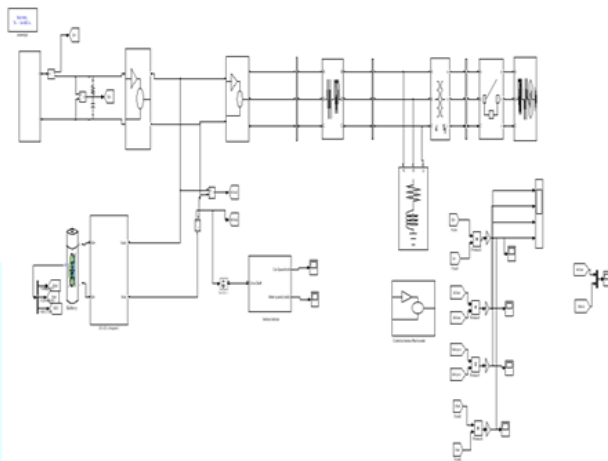

Case A-3 Fig Islanded Mode pv battery based completed diagram

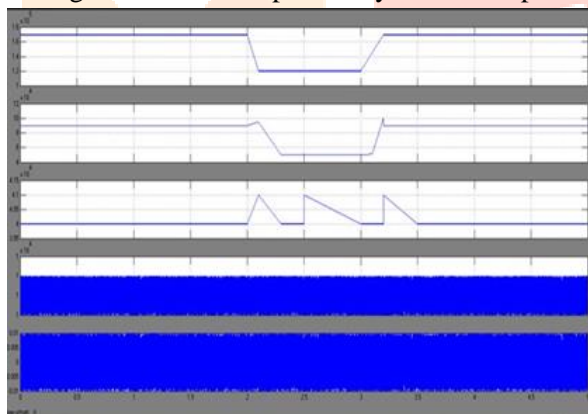

PV array in power-reference mode.

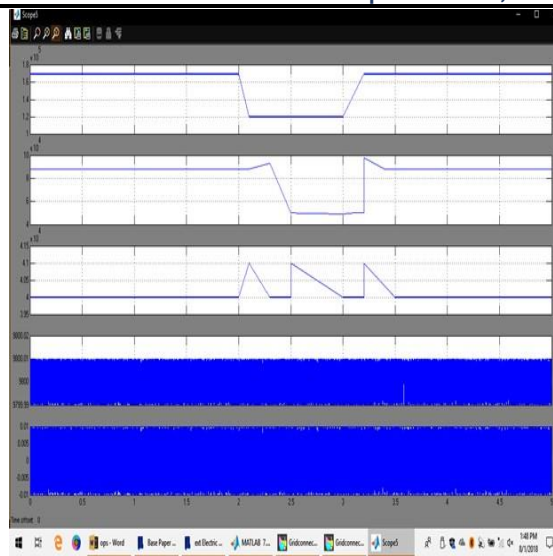

Case B-1

power flows of the PV-battery system with changing loads.

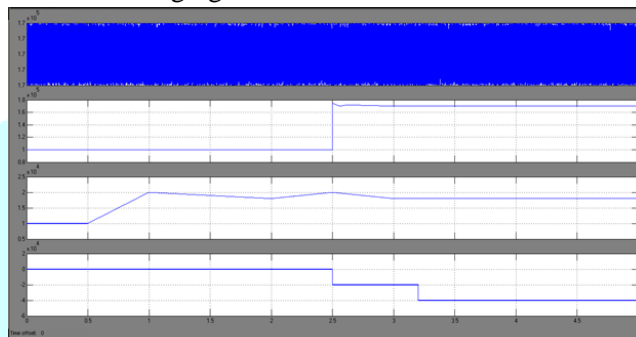

power flows of the PV-battery system dc voltage changing loads.

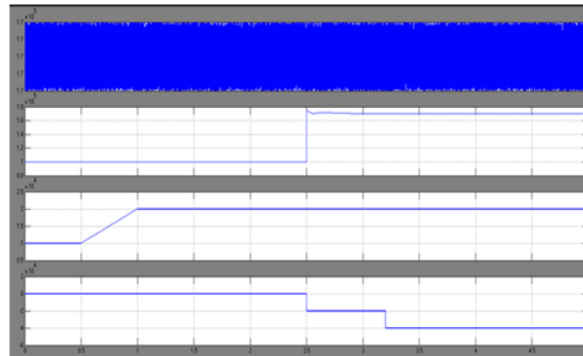

Case B-2

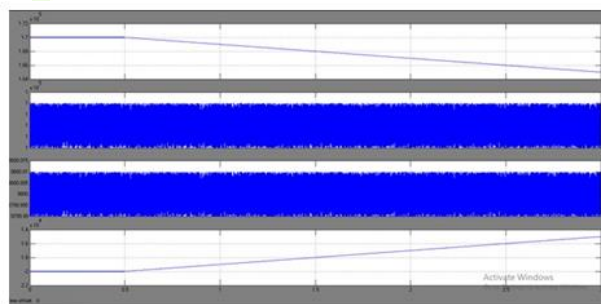

battery power changes with PV generation.

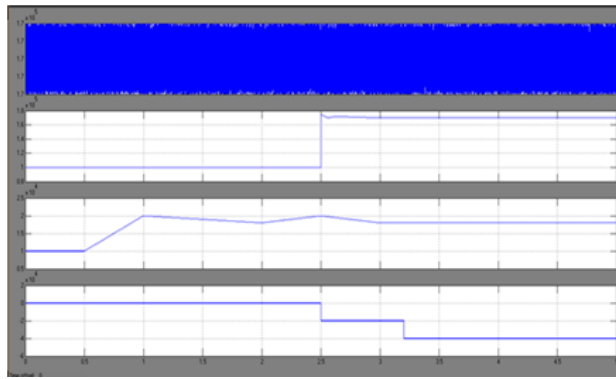

battery power changes Vdc with PV generation

## CONCLUSION

A complete analytical examination of a control and power management system (CAPMS) for hybrid PV-battery systems with both DC and AC buses and loads, operating in both grid-connected and islanded modes. The given CAPMS is capable of managing power flows in all units' converters in a flexible and effective manner, finally achieving power balance between the hybrid microgrid system and the grid. Furthermore, CAPMS guarantees that the system receives a dependable power supply when PV power varies owing to fluctuating irradiance or when the PV array is shut down due to faults. The CAPMS fully controls DC and AC buses in both grid-connected and islanded modes, ensuring a stable voltage environment for electrical loads even during transitions between these two modes. This also allows additional loads to access the system without extra converters, reducing operation and control costs. Numerous simulation and experimental case studies are carried out in Section IV that verifies the satisfactory performance of the proposed CAPMS.

## REFERENCES

- [1] T. A. Nguyen, X. Qiu, J. D. G. II, M. L. Crow, and A. C. Elmore, "Performance characterization for photovoltaic-vanadium redox battery microgrid systems," *IEEE Trans. Sustain. Energy*, vol. 5, no. 4, pp. 1379–1388, Oct 2014.
- [2] S. Kolesnik and A. Kuperman, "On the equivalence of major variable step-size MPPT algorithms," *IEEE J. Photovolt.*, vol. 6, no. 2, pp. 590–594, March 2016.
- [3] H. A. Sher, A. F. Murtaza, A. Noman, K. E. Addoweesh, K. Al-Haddad, and M. Chiaberge, "A new sensorless hybrid MPPT algorithm based on fractional short-circuit current measurement and P&O MPPT," *IEEE Trans. Sustain. Energy*, vol. 6, no. 4, pp. 1426–1434, Oct 2015.
- [4] Y. Riffonneau, S. Bacha, F. Barruel, and S. Ploix, "Optimal power flow management for grid connected PV systems with batteries," *IEEE Trans. Sustain. Energy*, vol. 2, no. 3, pp. 309–320, July 2011.
- [5] H. Kim, B. Parkhideh, T. D. Bongers, and H. Gao, "Reconfigurable solar converter: A single-stage power conversion PV-battery system," *IEEE Trans. Power Electron.*, vol. 28, no. 8, pp. 3788–3797, Aug 2013.
- [6] Z. Yi and A. H. Etemadi, "A novel detection algorithm for line-to-line faults in photovoltaic (PV) arrays based on support vector machine (SVM)," in *2016 IEEE Power and Energy Society General Meeting (PESGM)*, July 2016, pp. 1–4.
- [7] A. Merabet, K. Ahmed, H. Ibrahim, R. Beguenane, and A. Ghias, "Energy management and control system for laboratory scale microgrid based wind-PV-battery," *IEEE Trans. Sustain. Energy*, vol. PP, no. 99, pp. 1–1, 2016.
- [8] B. S. Borowy and Z. M. Salameh, "Methodology for optimally sizing the combination of a battery bank and PV array in a wind/PV hybrid system," *IEEE Trans. Energy Convers.*, vol. 11, no. 2, pp. 367–375, Jun 1996.
- [9] D. Abbes, A. Martinez, and G. Champenois, "Eco-design optimisation of an autonomous hybrid wind-photovoltaic system with battery storage," *IET Renewable Power Generation*, vol. 6, no. 5, pp. 358–371, Sept 2012.
- [10] H. Mahmood, D. Michaelson, and J. Jiang, "A power management strategy for PV/battery hybrid systems in islanded microgrids," *IEEE J. Emerg. Sel. Top. Power Electron.*, vol. 2, no. 4, pp. 870–882, Dec 2014.