



INTERNATIONAL JOURNAL OF CREATIVE RESEARCH THOUGHTS (IJCRT)

An International Open Access, Peer-reviewed, Refereed Journal

Automatic Lubrication System

Prof. Husain Shaikh¹, Dr. Harish Harsurkar², Lalit Kamte³, Kiran Tanwade⁴

¹Asst. Professor Mechanical Engineering Vidya Prasarini Sabha's College of Engineering and Technology, Lonavala

²HOD Mechanical Engineering Vidya Prasarini Sabha's College of Engineering and Technology, Lonavala

³Student Mechanical Engineering Vidya Prasarini Sabha's College of Engineering and Technology, Lonavala

⁴Student Mechanical Engineering Vidya Prasarini Sabha's College of Engineering and Technology, Lonavala

Abstract-

In Lubrication process lubricant is used as fluid in machining process can reduce the cutting temperature and provides the lubrication to work piece and tool. These increase the long life of the tool and good surface quality. There are many types of lubrication system is used in industry. This paper is review of Automatic Lubrication System which is used in industry. This system delivers controlled amount of lubricant to multiple location on a machine parts while the machine is working. The lubrication consists of greasing oil to different greasing points. This study involves with design and manufacturing of automatic lubrication system. This system gives safety to part and worker and it also minimize manpower required for lubrication system. Damage due to large greasing to part can be stopped. This paper also describes the parts which are used to construct of Automatic Lubrication System.

Keywords- Double acting pneumatic cylinder, Grease gun, Solenoid valve, Digital timer, connecting rod.

1. INTRODUCTION

Now a day many industry maintenance areas are decrease due to wrong lubrication. But there are the number of production machines and lubrication places that have need manual lubrication. By manual lubrication the many times the product is spoilage due to excess lubricant and large energy consumption. The manual lubrication is used in industry to done a job of maintenance operations. Due to this large

amount of lubricant is wastage and decrease production. There benefit is not compare to those provided by automated lubrication system in the terms of worker safety, production rate and etc. In automated lubrication system with the help of grease guns equal amount of lubricant in done on the system. Automation lubrication system protects the bearing failure by giving the proper amount of lubricant to the machine at proper time. The automation in lubrication system the crawler system arranged in heavy machinery. The big advantage of automation is that gives safety to labour. It other benefits of this it save the energy and material, increase quality efficiency. It control the excess amount of lubricant to givesthe final product the worker area. With many years experience in lubrication systems, Lincoln has different system solution to define these factors.

Lubricating grease is made from petroleum thick oil substance which is used as lubricant. The grease consists of oil and other lubricant that is mixed with a typically a soap, to form a semi solid. Lubricating grease contains some performance additives. Grease are a type of shear thinning fluid which define the viscosity of fluid is decreased undershear. The function of grease is that minimize the leakage as sealant. The features of grease is that posses a high initial viscosity, which depend on application of shear. The change in viscosity is called the Thixotropy. Lubricating grease is used in much industry to reduce the wear and friction between movable parts. Due to its semisolids character it act as seal thus preventing from leakage.

The main difference between the automated and manual lubrication is that in the accordance of manually applied lubricants, mechanic tend to lubricate chart. There are many advantages of automation over manual application. It is better to apply small amounts of grease at small time rather than high amounts of grease at large time. With manual application, the device is to apply as large grease as possible without causing harm due to large greasing, thereby maximize the re-lubrication times.

1.1 Application

- 1) Punching presses
- 2) Capstan laths
- 3) Hobbing machines
- 4) Milling machines
- 5) Shaping machines
- 6) Turing laths
- 7) Slotting machines
- 8) Spring making machines
- 9) Steel plants

1.2. Advantages

- 1) Less power consumption due to less friction
- 2) Less wear on the components
- 3) Reduce replacement costs and maintenance
- 4) Gives safety to worker
- 5) Reduce wastage of lubricant
- 6) Increased machine availability
- 7) All critical parts are lubricated according to location
- 8) Increased productivity
- 9) Reduce the downtime due to general maintenance

2. LITERATURE REVIEW

The automated lubrication system is play important role in lubrication where that manual lubrication cannot be done on the machine parts. After the survey on automated lubrication the right lubrication can provide new opportunities to increase profitability by reducing costs to operate machinery, improving reliability and safety, extending service interval and optimizing manpower resources.

Lincoln and SRK discuss the injecting the correct quantity of grease at proper interval is critical to bearing performance. Lincoln is creating the Lincoln grease based lubrication solution. This means now you have go to resource for advanced lubrication solution for any friction related application. This gives us a unique perspective how complex systems operate and how to optimize lubrication to achieve result that are both sufficient and cost effective. This save the time and labour as compared to manual lubrication.[1]

Muskat, M. Gulf research and development company Pittsburgh, Pennsylvania and Eviger H.H. h Equal amount of lubricant is distributed on components and increasing machines availability as explain the study of lubrication. It explain the effect of pressure variation of viscosity in the lubrication of plane slider. The Reynold theory is used to calculation the lubrication properties of plane slider with the viscosities are increase directly with pressure. The friction coefficient, film thickness and lubricant flow calculated for wedge angle and pivoted slider.[2]

Bowden, F. P. Council for scientific and industrial research, East Melbourne, Australia and Tabor, on March 1947 discuss the thin metallic films. It research discuss role of thin metallic film which reduce the friction and wear between metal surface. It explain metallic film surface properties is very low coefficient of friction.[3]

3. CONCEPT

In programme we have to in made Automatic Lubrication System by using pneumatic cylinder and grease gun. Lincoln invent Automatic Lubrication System based hydraulic is expensive than Automatic Lubrication System which is used pneumatic cylinder.

The double acting pneumatic cylinder is attached to handle of grease gun and its other end is attached to compressor. The compressor starts at deliver pressure 3bar and it moves the handle of grease gun to lower. And second piston of grease gun is delivered the grease to needed greasing area through nozzles attached. It get actuated when handle reach to switch. The pneumatic cylinder worked oppositely due to actuation of the switch. After this grease gun get return to original position. This process is working continues along the time interval of machine

4. DESCRIPTION OF COMPONENT

Components are used in the system are given follows:-

Pneumatic cylinder

Grease gun

3/2 Solenoid valve

Digital Timer

Connecting rod

3.1 Pneumatic Cylinder:-

Double acting pneumatic cylinder consists of two ports are used alternatively as supply and exhaust ports. It also consists a permanent magnet and cushioning rings.

3.1.1 Specification:-

End cap made of aluminium Piston rod is made of stainless steel Air supply can vary from 3bar to 10bar

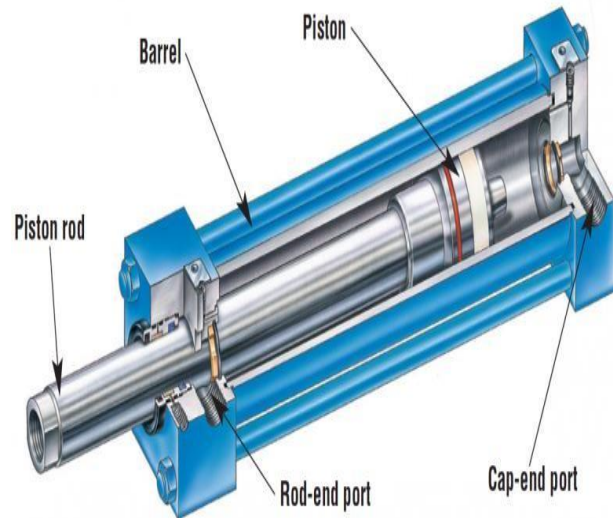

Fig 1: Double acting pneumatic cylinder

3.2 Grease Gun:-



Fig 2: Grease gun

A grease gun is a device which is used for lubrication. Grease gun is applied for the purpose of pumping a lubricant to some particular point. The most common styles of grease guns include the lever, pistol grip, hand grip etc. The lever style is the most economic and mostly used of the grease guns.

3.33/2 Solenoid Control Valve:-

Solenoid Valves are used to close or mix the liquid in a pipe. A 3/2 valve has three ports and two positions and operates between two circuits. 3/2 valves have different functions such as normally closed or opened. They usually consist of a spool inside a cylinder which is mechanically or electrically controlled. The movement of the spool stops the flow, thus it controls the fluid flow.



Fig 3: 3/2 solenoid control valve

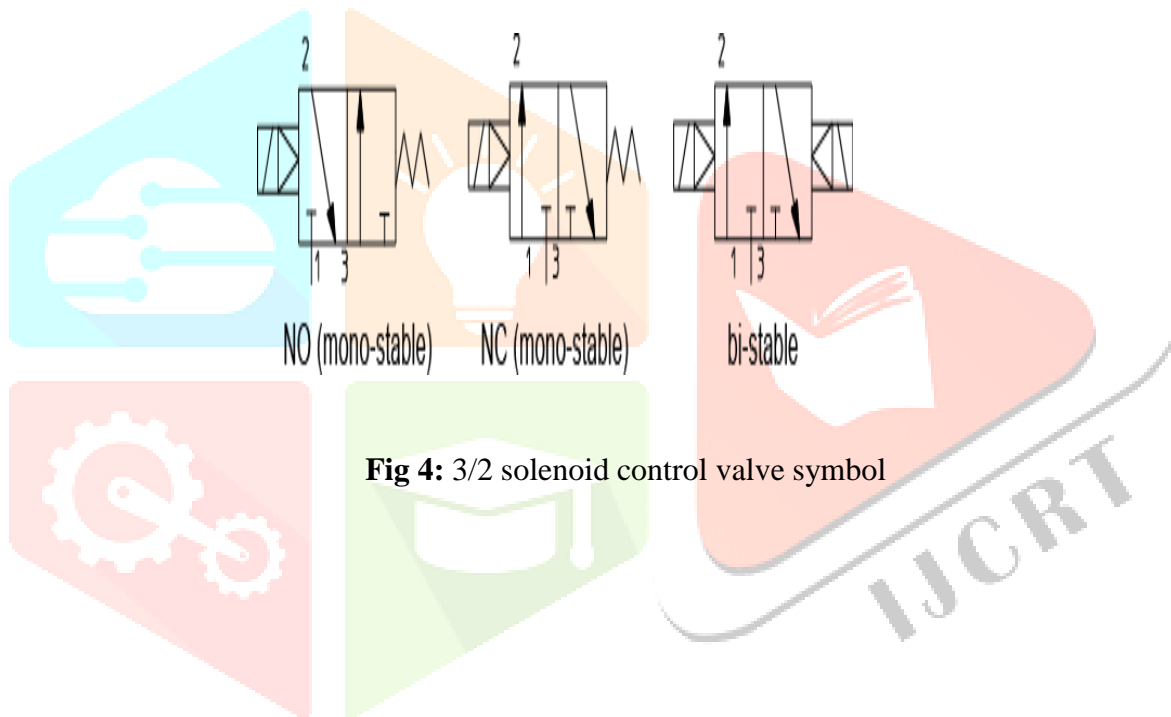

Fig 4: 3/2 solenoid control valve symbol

3.3.1 Specification: -

Table -1:

TYPE	3 Port 2 Position
Body Material	Aluminium
Operating Temperature	-10 To 80 degree Celsius
Coil Insulation and Protection Class	F Class, IP65
Seal Material	NBR(Buna N)
Plunger & Spring	Stainless Steel
Armature Tube	Brass
Operating Voltage	12V
Power Consumption	3W

3.4 Digital Timer :-

The digital timers are basically used in industry to control the operation with specified time interval of repetitive nature. It is basically a time clock with an arrangement for on or off operation at predetermine time interval.



Fig 5: Digital timer

3.5 Connecting Rod:-

In reciprocating engine connecting rod attached the piston to crankshaft. It transmits the motion and force between a piston and crank.



4. CONCLUSION

After the study of Automatic Lubrication System it concluded that the wastage of lubricant is reduced by control system optimization that a right amount of lubricant at right point. It reduce the man power consumption required for the lubricating the different grease point, maintenance costs and cost on wastage. It increases the production of the component and reduce time consumption This system gives the safety to worker and tool. The loss of grease is comparative less than manual greasing.

REFERENCES

- [1] Lincoln and SRK “injecting the quantity of grease at proper interval”
- [2] Muskat, M. Gulf research and development company, Pittsburgh, Pennsylvania and Evinger, H.H. – Effect of the pressure variation of viscosity on the lubrication
- [3] Bowden, F.P. Council for Scientific and Industrial Research, East Melbourne, Australia and Tabor, D on March 1947- The Lubrication by Thin Metallic Films and the Action of Bearing Metals
- [4] Bousu sch of Electr. Eng. And Automation, Henan Polytech. Univ., Jiaozou, China Li Wang the structure planning of the lubrication system , online monitoring of pressure and temperature.
- [5] Danilo de Jesus Oliveria, Luiz Gustavo Guermandia, “ Improving MQL in CBN grinding using compressed air wheel cleaning” , Journal of Materials Eng. 41 (2012) 1743-1749
- [6] Evelyn George et al., “retention of lubrication during sliding of mating surfaces”
- [7] Z.H. Nazria, M.Z.M., Rodya, Mond Fadzli Bin Abdollah, “Elastohydrodynamics Lubrication for Bio Based Lubricants” Elsevier Procedia Engineering 68 (2013)
- [8] M. Shahabuddin, H.H. Masjuki, M.A. Kalam, “Experimental investigation into tribological characteristics of biolubricant formulated from jatropha oil”5th BSME International Conference on Thermal Eng., Proceda Eng. (2013)
- [9] Mohamad Noor Harun, Zhongmin Jinb, Ardiyansyah Syhroma, “Influence of Lubrication Performance on WearFactor in Metal on Metal Hip Joint Replacement using Numerical Ananylise” the Malaysian International TrIbology conference 2013
- [10] S.M. Hafisa, Anila Rahayu, “Minimum quantity lubrication in cold work drawing process: Effects on forming load and surface roughness” , Elsevier Proceda Eng. (2013)
- [11] Mohamad Syahmi Shahron, “Taguchi Method Approach on effect of lubrication condition on surface roughness in milling operation”, Elsevier Procadia Engineering (2013)