



Design and Analysis of a Smart Ventilation System for Indoor Air Quality

Aditya Madakwara, Dr. Tejpal Parshivanikarb.

a: Student of M-Tech CAD/CAM, ME Department GHRCEMN.

b: Asst. Prof. & H. O. D., ME Department GHRCEMN.

Mechanical Department, G H Raison College of Engineering and Management, RTMNU University, Shradha Park, B-37/39, Hingna–Wadi Link Road, Maharashtra 440016.

Abstract — Indoor Air Quality (IAQ) has emerged as a critical determinant of human health, comfort, and cognitive productivity, particularly as urbanization leads individuals to spend approximately 90% of their lives in enclosed environments. Conventional ventilation systems, which typically operate on static schedules or manual controls, fail to respond to dynamic fluctuations in pollutant concentrations and occupancy levels. This lack of adaptability often results in an insufficient air circulation leading to the accumulation of hazardous contaminants such as carbon dioxide, VOCs and significant energy inefficiency due to unnecessary operation. This paper presents a comprehensive study on the design and implementation of an intelligent, IoT-based Smart Ventilation System. By integrating low-cost, high-efficiency sensors such as the MQ-135 for air quality and the DHT11 for temperature and humidity, the system enables real-time environmental monitoring via a microcontroller platform.

The proposed solution utilizes automated control algorithms to dynamically adjust exhaust fan speeds and air intake based on live sensor feedback, facilitating Demand-Controlled Ventilation. This project focuses on technical simplicity and low power consumption, making it a feasible intervention for residential, educational, and commercial spaces.

The system bridges the gap between environmental health and energy conservation to provide a cost-effective path toward healthier indoor ecosystems.

Keywords — Smart Ventilation System, Indoor Air Quality (IAQ), Internet of Things (IoT), MQ135 Sensor, DHT11 Sensor, Arduino Uno, Automated Ventilation, Air Quality Monitoring, Energy Efficiency, Environmental Monitoring, Smart Building, HVAC Automation, Real-Time Monitoring.

I. INTRODUCTION

Ventilation refers to the process of supplying fresh air to an enclosed space while removing contaminated or polluted air from that environment. It is one of the most crucial factors in maintaining IAQ, thermal comfort, and occupant health. Proper ventilation helps dilute indoor contaminants, regulate humidity, maintain oxygen concentration, and reduce airborne pollutants, thereby improving cognitive performance, productivity, and overall well-being [1], [2].

In modern buildings, where people spend 90% of their time indoors, indoor air quality has become a major environmental and public health concern [10], [17].

Indoor Air Quality (IAQ) directly affects the health, comfort, and productivity of occupants in homes, classrooms, laboratories, offices, hospitals, and industrial environments. Rapid urbanization, industrial growth, and the increasing use of airtight building structures for energy conservation have resulted in poor indoor ventilation and the accumulation of harmful pollutants [4], [5]. Common indoor pollutants include carbon dioxide (CO₂) generated from human respiration, particulate matter (PM), volatile organic compounds (VOCs), smoke, dust particles, and microbial contaminants such as mold and bacteria [10], [11]. According to the World Health Organization (WHO), poor indoor air quality is among the leading environmental health risks worldwide.

Continuous exposure to polluted indoor environments may cause headaches, respiratory

irritation, allergies, fatigue, asthma, reduced concentration, and long-term cardiovascular or pulmonary diseases [12], [17]. Traditional ventilation systems are generally designed with fixed airflow rates and manual operation, making them incapable of responding dynamically to changing indoor environmental conditions [3], [10].

These conventional systems often operate continuously regardless of occupancy levels or pollutant concentration, resulting in excessive energy consumption and inefficient ventilation performance [7], [15]. In many residential and institutional buildings, ventilation systems fail to maintain optimal indoor conditions due to insufficient monitoring and lack of automated control mechanisms [14], [16]. Therefore, there is a growing demand for intelligent and adaptive ventilation technologies capable of balancing indoor air quality with energy efficiency.

To address these challenges, smart ventilation systems have emerged as an effective solution for modern indoor environments. Smart ventilation integrates sensors, microcontrollers, wireless communication technologies, cloud platforms, and automated control mechanisms to monitor and regulate indoor air quality in real time [5], [6], [8]. These systems continuously collect environmental parameters such as temperature, humidity, gas concentration, and particulate matter levels and automatically adjust ventilation. [8], [12].

Unlike traditional ventilation systems, smart ventilation systems make data-driven decisions and provide demand-controlled ventilation

(DCV), significantly improving energy efficiency while maintaining healthy indoor conditions [15], [19].

Recent advancements in the Internet of Things (IoT) have accelerated the development of low-cost and intelligent IAQ monitoring systems [4], [6], [17].

Researchers have demonstrated the effectiveness of IoT-enabled ventilation systems using affordable hardware platforms such as Arduino, ESP8266, and low-cost sensors including MQ135 gas sensors and DHT11 temperature-humidity sensors [6], [9], [14], [16]. These technologies enable real-time monitoring, cloud-based data storage, wireless communication, and remote accessibility through mobile applications and web interfaces [4], [14]. Such systems are especially useful in small indoor environments where cost-effective solutions are required without compromising system performance and reliability.

Several researchers have also explored advanced computational and analytical techniques for improving ventilation system performance. CFD has become an important tool for analyzing airflow distribution, particulate matter dispersion, thermal comfort, and pressure variations inside buildings [11], [12]. Jung and Abdelaziz Mahmoud [10] demonstrated that mechanical ventilation systems effectively reduce indoor pollutant concentration in high-rise buildings.

Similarly, Kim et al. [13] studied passive cooling methods and sustainable building materials to improve thermal comfort and

reduce indoor temperature through optimized airflow patterns.

Artificial Intelligence (AI), machine learning, and predictive analytics are also playing an increasingly important role in next-generation smart ventilation systems [7], [8], [18], [19]. Zhang et al. [8] integrated machine learning algorithms with HVAC systems to optimize indoor air quality and energy consumption. Similarly, Patel and Singh [18] applied deep learning techniques for HVAC cooling optimization and achieved improved energy prediction accuracy. Chinyadza [19] further discussed AI-integrated Ventilation-on-Demand (VOD) systems capable of dynamically adjusting airflow based on real-time pollutant concentration and occupancy conditions, resulting in substantial energy savings and improved environmental control.

Smart ventilation systems are highly relevant in the context of sustainable and green building technologies. Green building standards such as LEED (Leadership in Energy and Environmental Design) and IGBC (Indian Green Building Council) emphasize energy-efficient HVAC systems and sustainable indoor environmental management [13], [15]. Smart ventilation systems support these objectives by minimizing unnecessary airflow operation and reducing electrical energy consumption while maintaining occupant comfort and safety [7], [18].

Therefore, intelligent ventilation technologies contribute not only to improved indoor air quality but also to sustainable energy management and environmental conservation.

In academic and research fields, smart ventilation represents an interdisciplinary area combining mechanical engineering, electronics, environmental science, computer engineering, and IoT technologies [6], [12], [17]. The integration of sensors, automation, wireless communication, cloud computing, and intelligent control systems has opened new opportunities for designing affordable and scalable indoor air management solutions [13], [15]. Wireless Sensor Networks (WSNs) further enhance system performance by enabling distributed environmental monitoring and faster response to changing indoor conditions [12].

This project aims to design and develop a cost-effective smart ventilation system capable of monitoring indoor air quality in real time using low-cost sensors and automated control mechanisms. The proposed system will monitor parameters such as harmful gas concentration, temperature, and humidity using MQ135 and DHT11 sensors and automatically control an exhaust fan or ventilation mechanism based on sensor feedback [14], [16]. The system is designed to be simple, energy-efficient, scalable, and suitable for small- to medium-sized indoor environments such as classrooms, laboratories, offices, and residential rooms.

The primary objective of this research is to improve indoor air circulation dynamically while minimizing system complexity and energy consumption.

By integrating IoT-based sensing, automated ventilation control, and real-time environmental monitoring, the proposed system seeks to provide healthier indoor conditions and

promote awareness regarding indoor air quality management [4], [7], [17]. Furthermore, this study presents a comprehensive analysis of smart ventilation technologies, existing research developments, and modern intelligent ventilation approaches that bridge the gap between air quality improvement and sustainable energy conservation [10], [15], [19].

II. LITERATURE

[1] M. K. Singh, A. Verma, and S. Roy presented the design and implementation of a smart ventilation system for improving indoor air quality through real-time monitoring and automated control mechanisms. Their system utilized low-cost sensors to measure carbon dioxide and particulate matter concentrations continuously. The ventilation system dynamically controlled exhaust fans based on predefined threshold levels and feedback control techniques. Experimental results showed nearly 35% faster IAQ response compared to conventional ventilation systems, demonstrating the effectiveness of automated environmental control in smart indoor applications. The authors also emphasized the importance of integrating low-

power embedded systems for cost-effective implementation in residential and commercial buildings.

Their research demonstrated that continuous monitoring and adaptive fan control can significantly improve indoor environmental conditions while reducing manual intervention and improving occupant comfort.

[2] A. Paul and R. Sharma proposed a smart exhaust fan controller based on Arduino Uno and MQ-series gas sensors for indoor air quality regulation. The system automatically adjusted fan speed according to pollutant concentration levels detected within indoor spaces. Their implementation demonstrated reliable sensing and responsive fan operation in pollution-prone environments such as kitchens and enclosed rooms. The research highlighted the practicality and affordability of integrating embedded automation into household ventilation systems. In addition, the study showed that automatic exhaust operation reduces energy wastage caused by unnecessary fan usage while ensuring effective pollutant removal. The proposed system was found to be highly suitable for domestic applications due to its simple hardware architecture, low maintenance requirements, and ease of deployment.

[3] P. Sharma, N. Srivastava, and R. Arora developed a low-cost IoT-based air quality monitoring system for smart city applications. Their system employed MQ-135 sensors for detecting CO₂ and VOC along with DHT11

sensors for temperature and humidity monitoring. Real-time environmental data was transmitted to cloud platforms for remote access and visualization.

The study validated sensor performance against standard monitoring stations and emphasized applications in environmental monitoring and public safety systems. The researchers further highlighted the scalability of IoT-based monitoring networks for urban pollution analysis and environmental management. Their

work demonstrated how cloud connectivity and wireless communication technologies can improve public awareness regarding air pollution conditions in densely populated areas.

[4] J. Saini, M. Dutta, and G. Marques presented an IoT-based indoor air quality monitoring framework integrating embedded systems and cloud computing technologies. Their system combined MQ-135 and SDS011 sensors with ESP8266 Wi-Fi modules to enable continuous air quality monitoring through mobile and web applications. Experimental analysis demonstrated high measurement accuracy compared to government air quality monitoring stations. The work emphasized the suitability of IoT-enabled IAQ systems for smart homes, educational institutions, and healthcare environments. The authors also discussed the importance of remote accessibility, data storage, and real-time alert systems in modern environmental monitoring applications. Their study highlighted the growing demand for intelligent sensing platforms capable of

providing continuous environmental feedback to users.

[5] A. Bhatia introduced an intelligent ventilation system based on real-time Air Quality Index (AQI) analysis using fuzzy logic controllers. The system integrated MQ-135 gas sensors, DHT22 sensors, and infrared sensors for occupancy detection. Fan speed and fresh air inlet operations were dynamically adjusted according to pollutant concentration and human presence. The proposed approach successfully improved indoor air quality while

simultaneously reducing overall power consumption through adaptive control strategies. The fuzzy logic controller enabled more flexible and efficient decision-making compared with conventional threshold-based systems. Their findings demonstrated that combining occupancy detection with pollutant monitoring can optimize both ventilation efficiency and energy utilization in smart indoor environments.

[6] K. Patel and D. Shah designed an IoT-based real-time indoor air quality monitoring and control system using Node MCU (ESP8266) modules for wireless communication. Their hardware implementation included MQ-135 gas sensors and DHT11 environmental sensors connected with relay-controlled exhaust fans. A web-based dashboard enabled real-time monitoring and visualization of environmental conditions. The study demonstrated improved indoor comfort, convenience, and air freshness in residential environments through automated ventilation

control. The researchers also emphasized the role of internet connectivity in enabling remote access and control of environmental systems.

Their implementation proved that low-cost IoT devices can effectively support smart home automation and indoor pollution management.

[7] P. Nair and V. Krishnan proposed an energy-efficient indoor air quality management system using predictive machine learning algorithms. Their system analyzed historical sensor data related to carbon dioxide concentration and temperature variation to forecast pollution trends and activate ventilation systems

proactively. Experimental results reported nearly 30% energy savings compared to conventional reactive ventilation systems. The work highlighted the importance of predictive analytics in sustainable building management applications. Their study also demonstrated that machine learning-based environmental forecasting can improve occupant comfort while minimizing unnecessary energy consumption. The integration of predictive algorithms with smart ventilation systems represents a significant advancement in intelligent building automation technologies.

[8] D. Zhang, T. Liu, and X. Wang presented an IoT-enabled smart HVAC control system integrated with machine learning algorithms for optimizing indoor air quality and energy efficiency. The system monitored multiple environmental parameters including carbon dioxide, particulate

matter, humidity, and temperature. Machine learning models dynamically adjusted HVAC operations according to occupancy and pollution trends.

Their results demonstrated enhanced thermal comfort and reduced energy consumption compared to traditional HVAC systems. The researchers further explained that adaptive HVAC operation based on predictive analysis can significantly reduce operational costs in commercial buildings. Their work highlighted the growing importance of AI-assisted control systems in modern smart infrastructure and sustainable building management.

[9] S. Kumar, R. Singh, and P. Jain developed a low-cost real-time indoor air quality monitoring

system using Arduino hardware integrated with IoT cloud platforms. The system incorporated MQ-series gas sensors, environmental sensors, and wireless communication modules for remote monitoring applications. Data visualization through cloud dashboards enabled continuous observation of indoor pollutant levels. The study emphasized the affordability and reliability of embedded IoT systems for IAQ monitoring. Their research also discussed the importance of cloud-based data storage and analysis for long-term environmental assessment. The proposed framework was found to be suitable for schools, offices, laboratories, and residential environments requiring continuous environmental supervision.

[10] C. Jung and N. S. Abdelaziz Mahmoud investigated ventilation strategies for mitigating indoor air pollutants in high-rise residential buildings.

Their study analyzed mechanical exhaust ventilation systems using mathematical dilution models and field measurements. Results showed that mechanical extraction significantly reduced concentrations of volatile organic compounds and formaldehyde within indoor environments. Their research supports the practical implementation of exhaust-based ventilation systems for residential IAQ improvement. The authors additionally discussed the influence of airflow distribution and ventilation placement on pollutant removal efficiency. Their findings demonstrated that properly designed exhaust ventilation systems can significantly improve occupant health and indoor environmental safety.

[11] C. A. Simatupang et al. conducted a numerical analysis of indoor air characteristics and particulate matter dispersion using Computational Fluid Dynamics (CFD). The study evaluated airflow distribution, pressure drop, and airflow resistance caused by window screens and ventilation arrangements. Their findings demonstrated how ventilation design directly affects pollutant dispersion and occupant comfort. The work provides important guidance for ventilation fan sizing and airflow optimization. The researchers also analyzed particle movement patterns and airflow turbulence within enclosed spaces.

Their study highlighted the importance of CFD-based simulation tool for designing efficient ventilation system before physical implementation.

[12] J. Liu, S. Zhu, M. K. Kim, and J. Srebric presented a comprehensive review of CFD analysis methods for personalized ventilation systems in indoor built environments. Their work discussed turbulence models, airflow simulation techniques, contaminant transport analysis, and boundary condition implementation used in indoor environmental studies. The paper established a strong theoretical foundation for simulation-based smart ventilation design and indoor airflow analysis. The authors emphasized that CFD simulations can significantly reduce design errors and improve ventilation efficiency in complex indoor spaces. Their review further highlighted the growing application of computational analysis in sustainable building design and advanced environmental engineering.

[13] J. Kim, H. Naganathan, S. Moon, and D. Jang analyzed the effects of passive cooling methods and eco-friendly building materials on indoor temperature reduction. Using airflow simulations and thermal analysis software, the researchers evaluated ventilation openings and air exchange rates under varying environmental conditions. Their results demonstrated improved thermal comfort and reduced cooling energy demand through optimized building ventilation strategies. The study further emphasized the importance of combining sustainable construction materials with

efficient ventilation design for green building applications. Their findings support the development of environmentally friendly and energy-efficient indoor climate control systems.

[14] D. J. D. K. Ghanraj proposed the design and analysis of an IoT-based pollution control system utilizing Arduino controllers and MQ135 gas sensors for indoor air monitoring. The system continuously monitored pollutant concentrations and compared them against predefined safety limits. Real-time data transmission through IoT platforms enabled cloud-based monitoring and analysis. The research highlighted the feasibility of low-cost pollution monitoring solutions for smart buildings and industrial environments. The study also discussed sensor calibration methods and automated alarm mechanisms for hazardous gas detection. Their implementation demonstrated reliable environmental monitoring performance suitable for continuous indoor air quality supervision.

[15] H. Dehra introduced an IoT-based smart building framework focused on energy efficiency, indoor air quality improvement, and noise characterization. The system analyzed ventilation rates and energy consumption using mathematical airflow equations and intelligent sensing systems. Real-time monitoring and automated ventilation adjustments improved both environmental quality and building energy performance. The study emphasized integrated environmental management for sustainable smart buildings. The researchers

further proposed mathematical models for calculating airflow requirements based on contaminant concentrations and occupancy conditions.

Their work highlighted the importance of balancing energy efficiency with occupant comfort in modern smart infrastructure.

[16] G. L. Krishna developed a real-time IoT-based air monitoring system with cloud-server integration for continuous environmental sensing. The system utilized gas sensors and wireless communication modules to detect harmful gases and trigger automatic alarms whenever pollutant levels exceeded safety thresholds. Their research focused on sensor calibration methods, threshold-based control systems, and remote air quality visualization techniques. The proposed system enabled rapid environmental assessment and improved response time for pollution management applications. Their work demonstrated the importance of accurate sensing and reliable cloud connectivity in real-time environmental monitoring systems.

[17] J. Saini, M. Dutta, and G. Marques conducted a systematic review of IoT-based indoor air quality monitoring systems. The review critically analyzed sensing technologies, communication protocols, cloud architectures, and monitoring frameworks used in existing IAQ systems. The authors identified challenges related to sensor accuracy, calibration, interoperability, and data reliability.

Their work provides important guidance for selecting suitable hardware and software architectures for future IAQ monitoring applications.

The review also highlighted emerging trends such as edge computing, artificial intelligence integration, and wireless sensor networks for advanced environmental monitoring systems.

[18] P. B. Patel and S. K. Singh proposed an intelligent air-cooling control system for HVAC applications using deep learning algorithms and predictive analytics. The system utilized Random Forest machine learning models to predict cooling requirements based on occupancy and environmental parameters. Experimental analysis demonstrated high prediction accuracy and improved energy efficiency in thermal HVAC operations. Their work highlighted the potential of AI-driven predictive control in smart cooling systems. The study further showed that predictive cooling strategies can significantly reduce unnecessary HVAC operation and operational costs in commercial and residential buildings.

[19] C. R. Chinyadza explored the integration of artificial intelligence into Ventilation on Demand (VOD) systems for modern smart

buildings. The study analyzed real-time gas and particulate matter data to optimize fan speed and airflow dynamically. The proposed AI-assisted ventilation strategy achieved significant energy savings while maintaining healthy indoor air quality levels. Results demonstrated up to 43% reduction in

energy consumption through adaptive airflow management techniques.

III. RESEARCH METHODOLOGY

This study adopts a design-oriented and experimental methodology to develop a smart ventilation system for improving indoor air quality (IAQ). The system is designed using an Arduino-based microcontroller integrated with low-cost sensors, including an MQ135 air quality sensor and a DHT11 temperature–humidity sensor, to continuously monitor environmental parameters. The collected data is processed in real time and compared with predefined threshold values to determine air quality conditions. Based on this evaluation, an automated control mechanism is implemented using a relay module to activate an exhaust fan whenever IAQ parameters exceed acceptable limits.

The developed prototype is tested in a controlled indoor environment to analyze system performance under varying conditions. Experimental data is collected and analyzed using time-based observation and comparative analysis to evaluate improvements in air quality, system response, and operational efficiency. The results are further validated through comparison with existing literature to ensure

reliability and effectiveness of the proposed system.

A. Research Approach

The research adopts a hybrid approach combining system design, experimental validation, and real-time data analysis.

To develop an efficient smart ventilation system for indoor air quality (IAQ) management. The approach focuses on integrating low-cost IoT-based sensors with a microcontroller platform to monitor environmental parameters such as air quality, temperature, and humidity. A rule-based control strategy is implemented to automatically regulate ventilation based on predefined threshold limits. The developed system is evaluated through controlled indoor experiments, where sensor data is continuously recorded and analyzed to assess system performance, responsiveness, and effectiveness in maintaining acceptable IAQ levels. This approach ensures a balance between system simplicity, cost-effectiveness, and functional reliability.

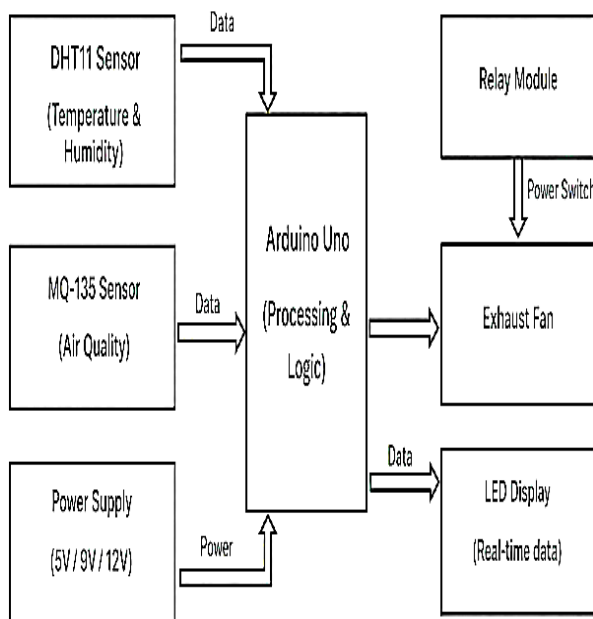

Fig. 1. Block Diagram

The proposed smart ventilation system is designed based on a layered architecture integrating sensing, processing, control, and



user interface components.

The sensing layer consists of air quality and environmental sensors that continuously measure parameters such as gas concentration, temperature, and humidity. The processing layer is built around a microcontroller unit that

Fig. 3. MQ135 Gas Sensor

collects and processes sensory data in real time. Based on the processed data, the control layer executes a decision-making algorithm to regulate the operation of the ventilation system through an actuator mechanism.

B. Component Design and Selection

The component design and selection for the proposed smart ventilation system are carried out based on criteria such as compatibility, cost-effectiveness, reliability, and application-specific requirements.

- An Arduino Uno microcontroller is selected as the central processing unit due to its simplicity, 5V logic compatibility, and ease of programming.
- For sensing air quality, the MQ135 gas sensor is utilized to detect harmful gases such as CO₂ and smoke.

- The DHT11 sensor is employed for measuring temperature and relative humidity.



Fig. 6. Exhaust Fan



Fig. 7. LED Display

- The control mechanism is implemented using a relay module, which enables safe switching of high-voltage devices such as the exhaust fan.



Fig. 5. Relay Module

- A wall-mounted axial exhaust fan is chosen to ensure efficient air circulation within the indoor environment.
- Additionally, an LED display is integrated to provide real-time feedback to the user.

The selection of these components ensures a balance between performance, affordability, and ease of implementation, making the system suitable for small-scale indoor applications.

C. System Development

The system development phase involves the

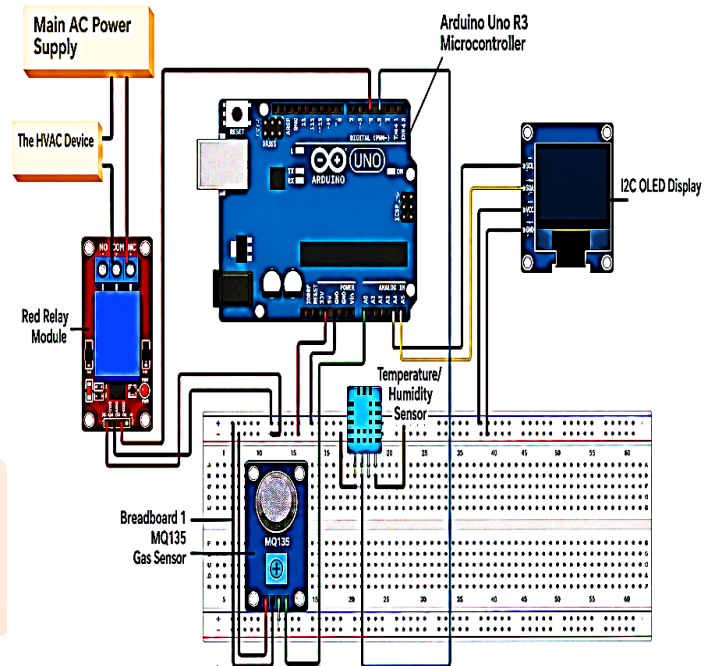

Fig. 8. Circuit Diagram

integration of hardware components implementation of control logic to realize the proposed smart ventilation system.

The Arduino Uno microcontroller is programmed using embedded C through the Arduino IDE to interface with the MQ135 air quality sensor and DHT11 temperature–humidity sensor.

The sensors continuously acquire environmental data, which is processed in real time by the microcontroller. Based on predefined threshold conditions, control signals are generated to operate a relay module, which in turn regulates the functioning of the exhaust fan.

D. Experimental Setup

The experimental setup is to evaluate the performance of the proposed smart ventilation system under controlled indoor conditions. The developed prototype is installed in a closed environment of approximately 10 × 10 feet to simulate real-life scenarios such as classrooms

or small offices with limited ventilation. The MQ135 sensor and DHT11 sensor are strategically placed within the room to continuously monitor air quality, temperature, and relative humidity. The exhaust fan is mounted to facilitate effective air circulation and removal of polluted air. The system operates continuously, collecting real-time data under varying environmental conditions, including normal and elevated pollutant levels. Sensor readings are displayed on an LCD unit and simultaneously monitored through an IoT-based

Fig. 10. Experiment Setup

interface. The system response, including activation and deactivation of the exhaust fan, is observed and recorded to evaluate its

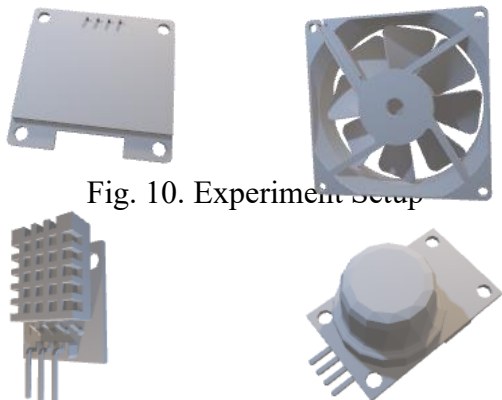

Fig. 11. CAD Models

```

+-----+
| AIR QUALITY MONITOR v3.0
| Sensors : DHT11 + MQ-135 (A0)
| Display : SH1106 128x64 OLED (I2C)
| Relay : Pin 7 — active LOW module
| Fan btn : Pin 8 — manual override
+-----+
*/

```

```

#include <DHT.h>
#include <Wire.h>
#include <U8g2lib.h>
#include <math.h>

```

```

// ---- Pins -----

```

```

#define DHT_PIN 2
#define GAS_PIN A0
#define RELAY_PIN 7
#define FAN_BTN 8

```

```

// ---- Objects -----

```

```

DHT dht(DHT_PIN, DHT11);

```

```

U8G2
U8G2
U8X8
);

```

```

// ----

```

```

#define
float

```

```

// ----

```

```

#define TEMP_HIGH 32.0 // °C
#define HUM_HIGH 50.0 // %
#define CO2_HIGH 800.0 // ppm

```

The complete system is assembled as a prototype using appropriate electrical connections and interfacing techniques to ensure reliable operation. Additionally, an LCD display is incorporated to provide real-time visualization of sensor readings, while IoT-based integration enables remote monitoring through mobile or web platforms. The developed system ensures continuous monitoring, automated response, and efficient control of indoor air quality parameters.

effectiveness in maintaining acceptable indoor air quality level.

IV. WORKING PRINCIPLE

The working principle of the proposed smart ventilation system is based on real-time monitoring and automatic control of indoor air quality parameters. The MQ135 sensor and DHT11 sensor continuously measure air quality, temperature, and humidity within the indoor environment. These sensor readings are processed by the Arduino microcontroller and compared with predefined threshold values. When any of the parameters exceed acceptable limits, the system automatically activates the exhaust fan through a relay module to remove polluted air and improve ventilation. Once the conditions return to normal levels, the system deactivates the fan to conserve energy. This continuous monitoring and control cycle ensures efficient maintenance of a healthy indoor environment with minimal manual intervention.

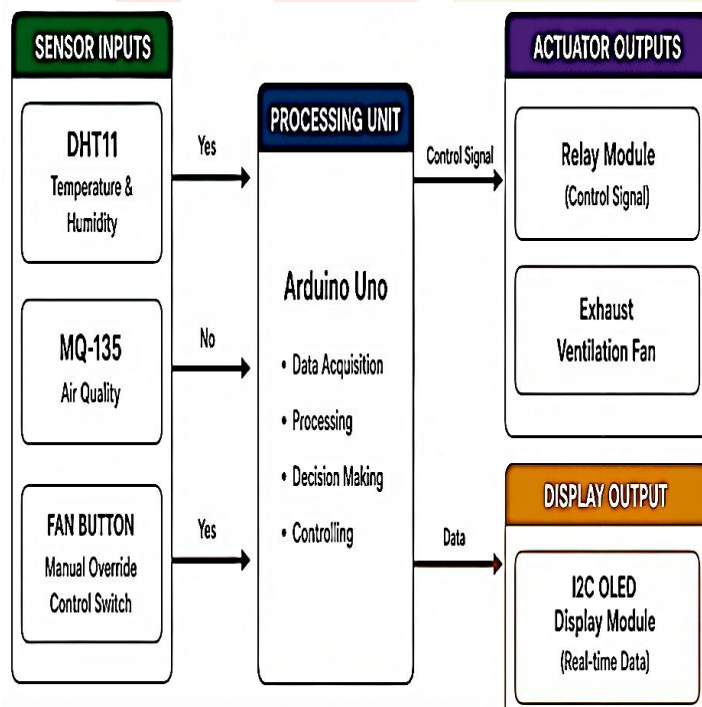

Fig. 12. Working Principle

V. RESULTS AND ANALYSIS

The performance of the proposed smart ventilation system is evaluated through experimental testing in a controlled indoor environment. Real-time data for temperature, relative humidity, and air quality were recorded at regular intervals using the integrated sensors. The collected data is analyzed using graphical representations to observe variations in environmental parameters over time. The results indicate that when the air quality or humidity exceeds predefined threshold limits, the system responds promptly by activating the exhaust fan, leading to a noticeable reduction in pollutant concentration and improvement in indoor conditions.

Similarly, temperature levels are maintained within a comfortable range through automatic ventilation control.

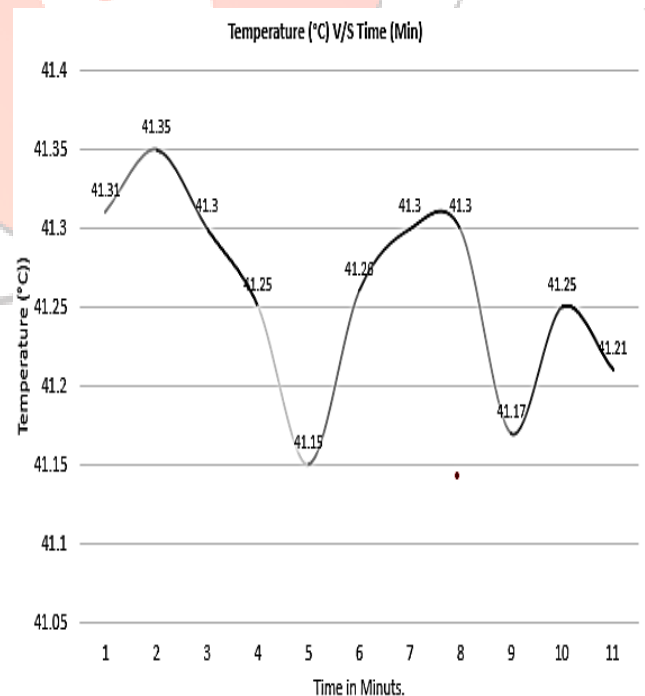

Fig. 13. Temperature Variation With Time

It is observed from Fig. 13. the temperature profile exhibits a gradual decline followed by stabilization, indicating effective heat removal through controlled ventilation. The system maintains thermal conditions within an acceptable comfort range, demonstrating efficient regulation of indoor temperature and contributing to overall thermal comfort and IAQ stability.

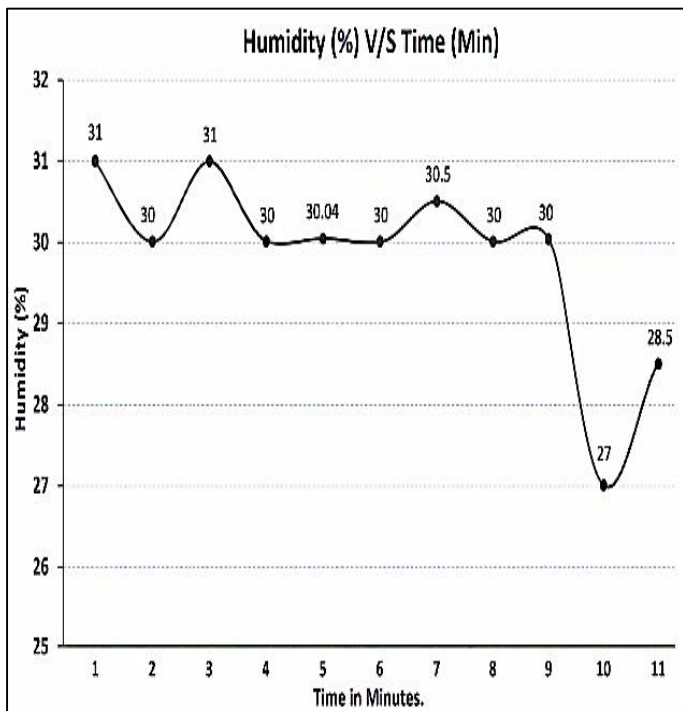

Fig. 14. Humidity Variation With Time

It is observed from Fig. 14. the humidity trend shows a consistent decrease from elevated levels toward an optimal range, reflecting the system’s capability to regulate moisture content through ventilation. This reduction minimizes the risk of discomfort and microbial growth, thereby enhancing indoor environmental quality and maintaining balanced IAQ conditions.

It is observed from Fig. 15 the smoke concentration initially fluctuates due to pollutant

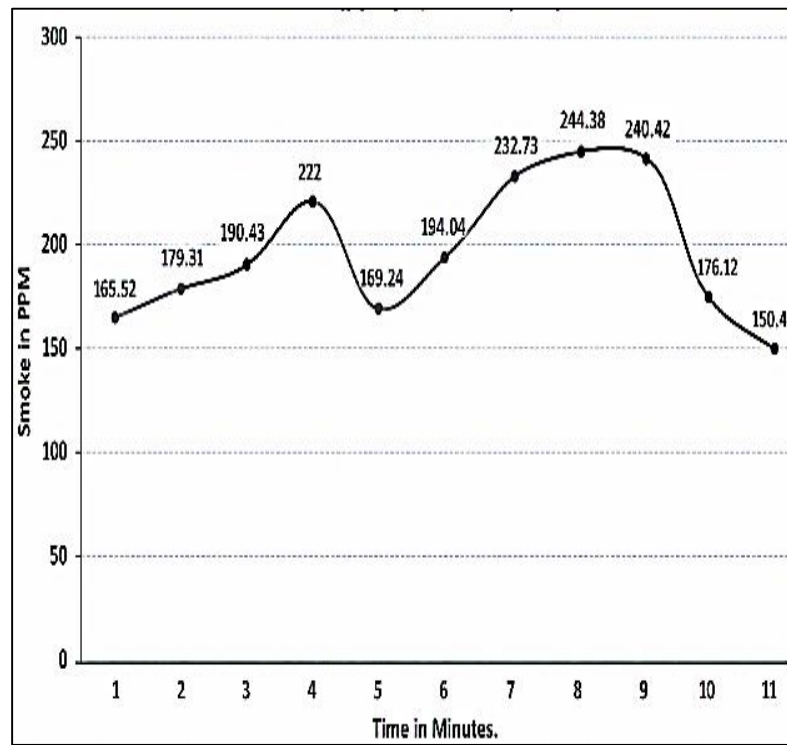

Fig. 15. Smoke Variation With Time

accumulation but shows a significant reduction

Table. 1. Comparative Analysis after system activation. This behavior indicates efficient pollutant removal and validates the responsiveness of the control mechanism. The system effectively maintains air quality within permissible limits, ensuring improved IAQ.

The system demonstrates stable operation, quick response time, and effective regulation of indoor air quality. These observations confirm that the proposed system provides an efficient, low-cost solution for maintaining healthy indoors.

VI. COMPARATIVE ANALYSIS

The comparative analysis of the proposed smart ventilation system was carried out by comparing its

performance with conventional ventilation systems and existing IoT-based ventilation

approaches. The analysis was based on important parameters such as air quality monitoring capability, automation level, energy efficiency, response time, real-time monitoring, cost-effectiveness, and operational reliability. Conventional ventilation systems generally operate manually or at fixed time intervals without considering actual indoor environmental conditions. Such systems are unable to dynamically respond to changes in pollutant concentration, temperature, or humidity levels. As a result, they often lead to unnecessary energy consumption and inefficient air circulation. In contrast, the proposed smart ventilation system continuously monitors indoor environmental parameters using MQ135 and DHT11 sensors and automatically controls the exhaust fan according to real-time sensor feedback. The proposed system demonstrated significantly improved response time and environmental regulation compared to traditional ventilation methods.

The comparative performance evaluation is summarized in Table below :

Parameter	Conventional Ventilation	Existing IoT Monitoring System	Proposed Smart Ventilation System
Real-Time Monitoring	No	Yes	Yes
Automatic Ventilation Control	No	Limited	Yes
Energy Efficiency	Low	Medium	High
Pollutant Detection	Limited	Moderate	High
Response Time	Slow	Moderate	Fast
Remote Monitoring	No	Yes	Yes
Cost Effectiveness	Medium	Medium	High
Human Intervention	High	Medium	Low
Indoor Air Quality Improvement	Moderate	Good	Excellent

During experimental testing, the system rapidly detected increased pollutant concentration and activated the exhaust fan automatically, resulting in noticeable reduction of smoke concentration and stabilization of temperature and humidity levels. This automatic control mechanism minimizes human intervention and improves overall indoor air quality management.

Compared to existing IoT-based air monitoring systems that only provide monitoring and data visualization, the proposed system integrates both monitoring and automated ventilation control. This enables real-time corrective action rather than only passive observation of environmental conditions.

Additionally, the use of low-cost components such as Arduino Uno, MQ135 sensor, DHT11

sensor, and relay modules makes the system economically suitable for classrooms, laboratories, offices, and residential environments.

The analysis clearly indicates that the proposed smart ventilation system provides superior performance in terms of automation, environmental monitoring, response speed, and energy efficiency. The integration of IoT technology with automated ventilation control enables intelligent indoor air management while maintaining low implementation cost.

VII. CONCLUSION

- The present study successfully demonstrates the design and implementation of a smart ventilation system for improving indoor air quality using a low-cost, IoT-based approach.
- The developed system effectively monitors important environmental parameters such as air quality, temperature, and humidity in real time.
- The system automatically controls ventilation based on sensor readings, ensuring efficient air circulation and improved indoor conditions.
- Experimental results confirm that the proposed system helps maintain indoor environmental parameters within acceptable limits by reducing pollutant concentration.
 - The integration of sensors, microcontrollers, and automated control mechanisms ensures

reliable operation with minimal human intervention.

- The proposed system is energy-efficient, simple in design, and cost-effective for practical implementation.
- The system is suitable for small indoor environments such as classrooms, offices, and residential spaces.
- Overall, the proposed smart ventilation system provides a practical, scalable, and effective solution for maintaining a healthier indoor environment.

VIII. FUTURE SCOPE

The proposed system can be further enhanced by incorporating advanced sensors capable of detecting a wider range of pollutants such as carbon dioxide (CO₂), volatile organic compounds (VOCs), and fine particulate matter (PM_{2.5} and PM₁₀) with higher accuracy. In future developments, predictive and adaptive control algorithms can be integrated to optimize ventilation performance based on environmental conditions and occupancy patterns, thereby improving energy efficiency. The implementation of cloud-based data storage and remote monitoring systems would enable users to access real-time indoor air quality information from anywhere through internet.

Additionally, machine learning and artificial intelligence techniques can be applied to analyze environmental data, identify pollution trends, and make intelligent decisions for automatic ventilation control.

The system can also be upgraded with a compact PCB-based hardware design to improve reliability, portability, and suitability for practical real-world deployment. Integration of wireless communication technologies such as Wi-Fi and Bluetooth can further enhance IoT connectivity and support smart building applications.

Future work may also include the development of a mobile application or web-based dashboard for user-friendly monitoring, control, and alert notifications.

Furthermore, renewable energy sources such as solar power can be incorporated to make the system more sustainable and energy-efficient. The proposed system can also be extended for use in larger environments such as hospitals, laboratories, industries, shopping malls, and smart cities, where maintaining indoor air quality is highly important. Additional safety features, including automatic alarms and emergency ventilation mechanisms, can also be integrated to improve overall system reliability and user safety.

IX. ACKNOWLEDGMENT

The author would like to express sincere gratitude to Dr. Tejpal Parshiwani for his valuable guidance, continuous support, and insightful suggestions throughout the course of this research work. His expertise and encouragement played a crucial role in the successful completion of this project. The

author also extends thanks to the Department of Mechanical Engineering at G H Raisoni College of Engineering and Management for providing the necessary facilities and a conducive environment for carrying out this research. Finally, heartfelt appreciation is given to all those who directly or indirectly contributed to the completion of this work.

X. REFERENCES

- 1] M. K. Singh, A. Verma, and S. Roy, 'Design and Implementation of a Smart Ventilation System for Indoor Air Quality Control,' Int. Conf. Sustainable Computing, Springer, 2020.
- 2] A. Paul and R. Sharma, 'Smart Exhaust Fan Controller for Indoor Air Quality Regulation,' Int. J. Computer Applications, vol. 182, no. 42, 2019.
- 3] P. Sharma, N. Srivastava, and R. Arora, 'A Low-Cost Air Quality Monitoring System for Smart Cities Using IoT,' IJRTE, vol. 8, no. 4, 2019.
- 4] J. Saini, M. Dutta, and G. Marques, 'Internet of Things for Indoor Air Quality Monitoring,' Springer, 2021.
- 5] A. Bhatia, 'Design of an Intelligent Ventilation System Based on Air Quality Index,' IEEE Int. Conf. Green Technologies, 2020
- 6] K. Patel and D. Shah, 'IoT-Based Real-Time Indoor Air Quality Monitoring and Control System,' IJERT, vol. 9, no. 3, 2020.

- 7] P. Nair and V. Krishnan, 'Energy Efficient Indoor Air Quality Management System Using Predictive Algorithms,' *Int. J. Smart Home*, vol. 13, no. 2, 2019.
- 8] D. Zhang, T. Liu, and X. Wang, "IoT-Enabled Smart HVAC Control System Using Machine Learning for Indoor Air Quality and Energy Optimization," 2021.
- 9] S. Kumar, R. Singh, and P. Jain, "Low-Cost Real-Time Indoor Air Quality Monitoring System Using Arduino-Based IoT Platform," 2020.
- 10] C. Jung and N. S. Abdelaziz Mahmoud, "Ventilation Strategies for Mitigating Indoor Air Pollutants in High-Rise Residential Buildings: A Case Study in Dubai," *Atmosphere*, vol. 14, no. 11, p. 1600, 2023.
- 11] C. A. Simatupang *et al.*, "Numerical Analysis of Indoor Air Characteristics and Window Screen Influence on Particulate Matter Dispersion Using Computational Fluid Dynamics," *Environmental Health Insights*, vol. 18, 2024.
- 12] J. Liu, S. Zhu, M. K. Kim, and J. Srebric, "A Review of CFD Analysis Methods for Personalized Ventilation in Indoor Built Environments," *Sustainability*, vol. 11, no. 15, p. 4166, 2019.
- 13] J. Kim, H. Naganathan, S. Moon, and D. Jang, "Optimizing Comfort and Sustainability: The Impact of Passive Cooling and Eco-Friendly Materials on Indoor Temperature Reduction," *Buildings*, vol. 14, no. 10, p. 3218, 2024.
- 14] J. D. K. Ghanraj, "Design and Analysis of IoT-Based Pollution Control System," *Lingaya's Vidyapeeth Research Journal*, 2021.
- 15] H. Dehra, "An IoT Scheme for Energy Efficiency, IAQ with Noise Characterization and Measurement in Smart Buildings," *IBPSA Publications*, 2025.
- 16] Krishna, G. L. (2022). Real-Time IoT-Based Air Monitoring System with Cloud-Server Integration for Continuous Environmental Sensing. *International Journal of Advanced Research in Electronics and Communication Engineering*, 11(4), 210–216.
- 17] Research in Electronics and Communication Engineering, 11(4), 210–216.
- 18] Saini, J., Dutta, M., & Marques, G. (2020). A Comprehensive Review of IoT-Based Indoor Air Quality Monitoring Systems. *Sensors*, 20(6), 1608.
- 19] Patel, P. B., & Singh, S. K. (2021). Intelligent Air-Cooling Control System for HVAC Applications Using Deep Learning Algorithms and Predictive Analytics. *International Journal of Smart Engineering Systems*, 9(3), 145–152.

- 20] Chinyadza, C. R. (2026). Integrating Artificial Intelligence into Ventilation on Demand (VOD) Systems for Modern Smart Buildings: Current Practice and Future Promises. PMC12900089.

