



IOT BASED ENERGY MONITORING SYSTEM USING RASPBERRY PI PICO

K.Kartheek¹, R.V.Neha², D.Lohith³, J.Sushmitha⁴, A.Tharun Sai⁵

¹Assistant Professor, ^{2,3,4,5}Students

¹Dept. of EEE,

¹Matrusri Engineering College, Hyderabad, India

Abstract: Traditional approaches to monitoring energy consumption often rely on basic meters or manual observation, which provide limited information about real-time usage. These methods are time-consuming, lack detailed analysis, and do not offer continuous monitoring of electrical loads. In many cases, users are unable to track individual load consumption or identify inefficient energy usage patterns. Additionally, the absence of remote access makes it difficult to monitor energy data from different locations. These limitations reduce the effectiveness of energy management and hinder timely detection of abnormal consumption or faults.

To overcome these challenges, this paper presents an IoT-based energy monitoring system using Raspberry Pi Pico W. The proposed system measures electrical parameters such as current and estimates energy consumption for multiple loads. The collected data is processed by the controller and transmitted to a cloud platform for real-time monitoring and analysis. Users can access this data remotely, enabling better understanding and management of energy usage.

The system eliminates the need for manual intervention and provides continuous monitoring with improved convenience. It also offers features such as data logging, remote accessibility, and visualization of energy consumption patterns. Although the system is not intended for billing-grade accuracy, it provides a practical and cost-effective solution for real-time energy monitoring applications.

Overall, the proposed system supports efficient energy utilization by providing users with meaningful insights into their consumption behavior, making it suitable for residential and small-scale applications.

Index Terms - IoT, Energy Monitoring System, Raspberry Pi Pico W, Smart Energy Management, Real-Time Monitoring, Cloud-Based Data Logging, Load Analysis

I. INTRODUCTION

This paper presents the design and implementation of an IoT-based energy monitoring system using the Raspberry Pi Pico W. The system is developed to monitor and analyze electrical energy consumption for multiple loads, both individually and collectively. Three separate loads are connected, each monitored using current sensors to track load current and estimate energy usage effectively.

The acquired data is processed by the microcontroller to compute power and energy consumption in kilowatt-hours (kWh) for each load. In addition to individual measurements, the system also determines the total energy consumed by all connected loads. A regulated power supply ensures stable and reliable operation of the system components.

A 20×4 LCD display is used to provide real-time information such as current, estimated energy consumption of each load, and total energy usage. For remote access, IoT integration is implemented using the ThingSpeak platform, enabling data logging and monitoring from any location. This allows users to observe consumption patterns and manage energy usage more efficiently.

The proposed system is suitable for residential, commercial, and small-scale industrial applications where monitoring multiple loads is essential. Although the system estimates energy consumption based on sensed parameters, it provides a practical and cost-effective solution for real-time energy monitoring and analysis, helping users improve overall energy efficiency.

II. LITERATURE REVIEW

Veerakumar P. [1] proposed an IoT-based interactive remote monitoring system designed for large-scale industrial and residential applications. The system supports multiple communication methods such as GPRS, SMS, and email, enabling efficient remote monitoring and control of electrical devices.

Harvard Swart A.J. [2] developed a cost-effective energy monitoring system using the ESP8266 NodeMCU to measure energy output and ambient temperature in a pico-solar setup. While the system demonstrates effective remote monitoring, its application is limited to specific use cases, and scalability for general household monitoring remains a challenge.

Dahlan et al. [3] designed a monitoring device capable of recording and displaying real-time parameters such as power consumption, energy usage, cost, and CO₂ emissions. Although the system provides comprehensive monitoring features, it does not support direct integration with existing energy meters, limiting real-time unit tracking.

Rao and Sudheer [4] presented a low-cost energy monitoring system aimed at identifying high power-consuming devices and promoting energy savings. The system uses a mobile application developed with MIT App Inventor; however, limitations in interface design and functionality may affect user experience and system flexibility.

Abubakar Salisu et al. [5] proposed an IoT-based household energy monitoring and control system using an ESP32 microcontroller. The system enables remote monitoring and control of electrical loads and supports energy conservation. However, the use of MATLAB for implementation may introduce performance constraints, particularly in real-time applications.

III. SYSTEM ARCHITECTURE / BLOCK DIAGRAM DESCRIPTION

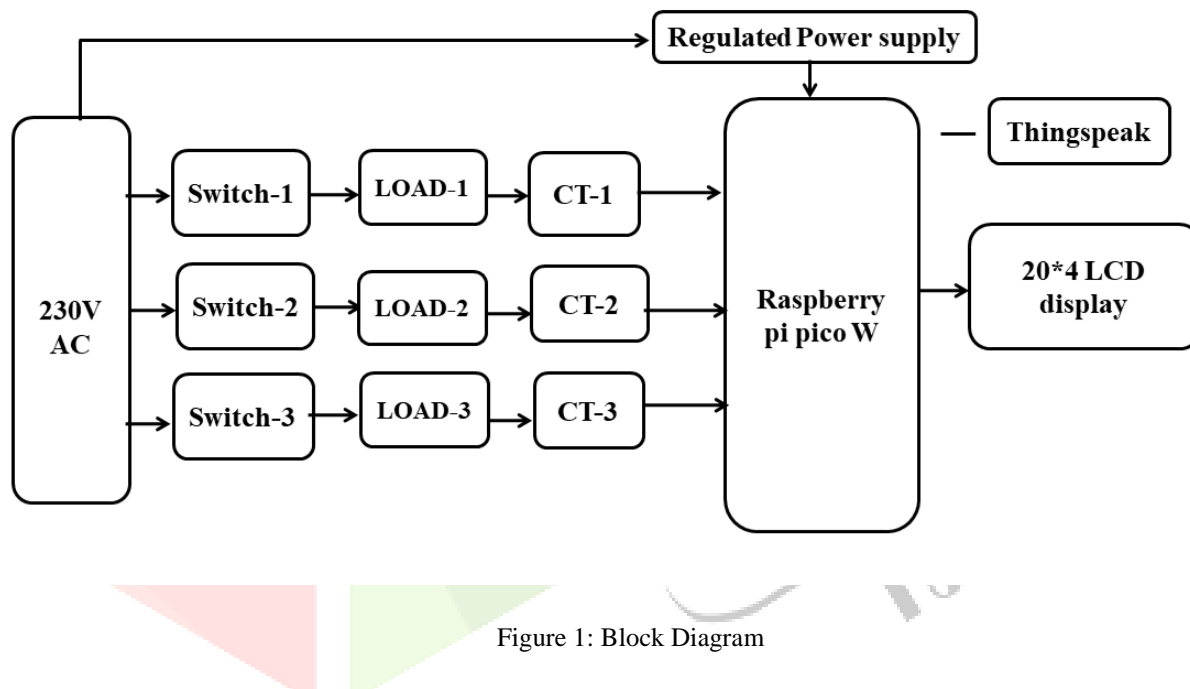

Figure 1: Block Diagram

The proposed system is designed to monitor the energy consumption of multiple electrical loads using an IoT-enabled embedded platform. The input supply of 230 V AC is distributed to three independent loads through individual switches. Each switch allows control over its corresponding load, enabling separate operation and monitoring. To measure the current drawn by each load, current sensors (CT-1, CT-2, and CT-3) are connected in series with the respective loads. These sensors continuously capture the current signals and provide proportional outputs to the controller. This arrangement enables accurate measurement of individual load currents without direct electrical contact. The sensed data from all CT sensors is fed into the Raspberry Pi Pico W, which acts as the central processing unit of the system. A regulated power supply ensures stable operation of the controller and associated components. The microcontroller processes the input signals to compute electrical parameters such as current, power, and energy consumption for each load, as well as the total consumption. For local monitoring, a 20×4 LCD display is used to present real-time values including load-wise current, energy usage, and overall consumption. In addition, the system is integrated with the ThingSpeak cloud platform using built-in Wi-Fi capability of the Raspberry Pi Pico W. This allows remote monitoring, data logging, and analysis of energy usage from any location.

Overall, the system provides an effective solution for real-time, multi-load energy monitoring with both local display and remote access capabilities.

IV. HARDWARE DESIGN

4.1 Raspberry Pi Pico W

Raspberry Pi Pico W acts as the central controller, providing processing capability and built-in Wi-Fi for IoT communication. It interfaces with sensors, control devices, and the cloud platform for real-time monitoring and control.

Specifications:

- Processor: RP2350 (dual-core Arm Cortex-M33 or RISC-V)
- Operating Voltage: 1.8 V – 5.5 V
- GPIO Pins: 40
- Connectivity: Wi-Fi (802.11 b/g/n)
- Operating Temperature: -20°C to 70°C



Figure 2: Raspberry pi pico W

4.2 Current Sensors

Current sensors are used to measure the current drawn by each load. They operate on electromagnetic induction, producing a scaled-down current proportional to the load current, which ensures safe and isolated measurement. In this system, three current sensors are employed to monitor three loads independently. Each sensor is connected in series with its respective load, enabling real-time current measurement. The sensor outputs are conditioned and provided to the Raspberry Pi Pico W for further processing. The measured current values are used to calculate power and energy consumption. Current sensors are preferred due to their accuracy, electrical isolation, and suitability for AC applications.



Figure 3: Current Sensors

4.3 Load and Switching Arrangement

Three electrical loads are connected to the system, each controlled by an individual switch. This arrangement allows independent operation and monitoring of each load. The switching mechanism enables users to turn loads ON or OFF manually, while the system continuously measures the corresponding energy consumption.

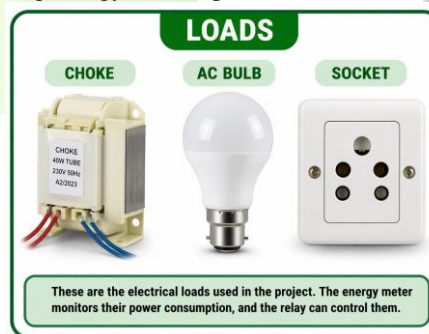

Figure 4: Loads

4.4 Regulated Power Supply

A regulated power supply unit is used to provide a stable DC voltage to the Raspberry Pi Pico W and associated components. It converts the 230 V AC input supply into a suitable low-voltage DC output, ensuring reliable and uninterrupted operation of the system. Proper voltage regulation is essential to prevent fluctuations that could affect measurement accuracy and system performance.

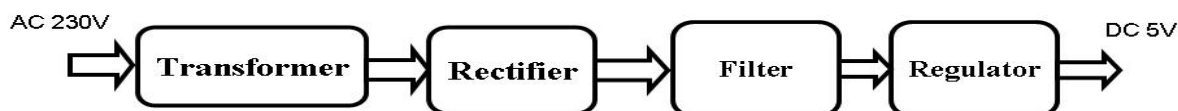

Figure 5: Regulated power supply block diagram

4.5 20×4 LCD Display

A 20×4 LCD display is incorporated to provide real-time visualization of system parameters. It displays important information such as current, individual energy consumption of each load, and total energy usage. This enables users to monitor energy data locally without the need for external devices.



Figure 6: LCD Display

4.6 IoT Communication Module

The built-in Wi-Fi module of the Raspberry Pi Pico W is utilized for IoT communication. It enables the system to transmit data to the ThingSpeak cloud platform for remote monitoring and storage. This feature allows users to access energy consumption data from anywhere and supports data analysis and visualization.

V. SOFTWARE DESIGN

The software design of the proposed system focuses on accurate data acquisition, real-time processing, and reliable IoT communication. The Raspberry Pi Pico W is programmed using embedded firmware to interface with sensors, perform calculations, and transmit data to the cloud.

5.1 Development Environment

The system is developed using MicroPython/C, which provides flexibility and ease of implementation for embedded applications. The program is structured into modules for sensor reading, data processing, display control, and communication.

5.2 Data Acquisition

The analog signals from the current sensors are read through the ADC channels of the controller. These signals are sampled at regular intervals to ensure accurate measurement of load current.

5.3 Data Processing

The acquired current values are processed to calculate electrical parameters such as current, power, and energy consumption. Energy usage is computed over time for each load as well as for the total system.

5.4 Display Control

A 20×4 LCD is interfaced with the controller to display real-time data, including current and energy consumption for individual loads and total usage. The display is updated periodically.

5.5 IoT Communication

The built-in Wi-Fi module is used to connect the system to the internet. Data is transmitted to the ThingSpeak platform using HTTP protocols. This enables remote monitoring, data logging, and visualization.

VI. PROTOTYPE SETUP

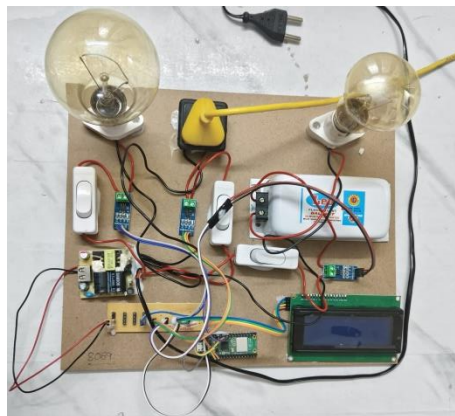

Figure 7: Prototype setup

VII. RESULTS AND DISCUSSION

The proposed IoT-based energy monitoring system was implemented and tested with three independent electrical loads under different operating conditions. The system successfully measured and displayed real-time current and energy consumption for each load, as well as the total energy usage.

The readings obtained from the current sensors were processed by the Raspberry Pi Pico W and displayed on the 20×4 LCD. The measured values showed consistent and stable performance, indicating proper functioning of the sensing and processing units. The system was able to differentiate the energy consumption of individual loads accurately, which is essential for identifying high-energy-consuming devices.

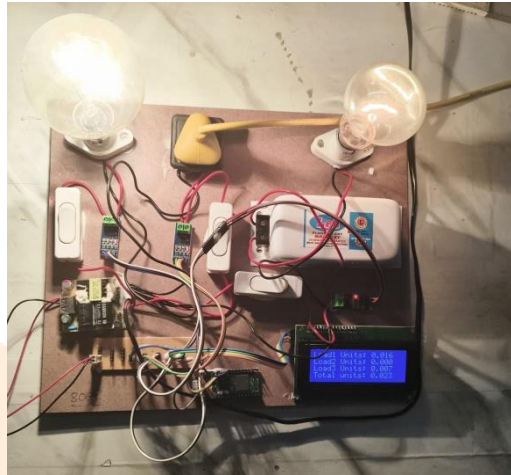

Figure 7: Prototype with energy monitoring of loads

The calculated power and energy values were also transmitted to the ThingSpeak cloud platform. The uploaded data was visualized in the form of graphs, enabling easy analysis of consumption patterns over time. The IoT functionality worked reliably, with minimal delay in data transmission, allowing near real-time remote monitoring.

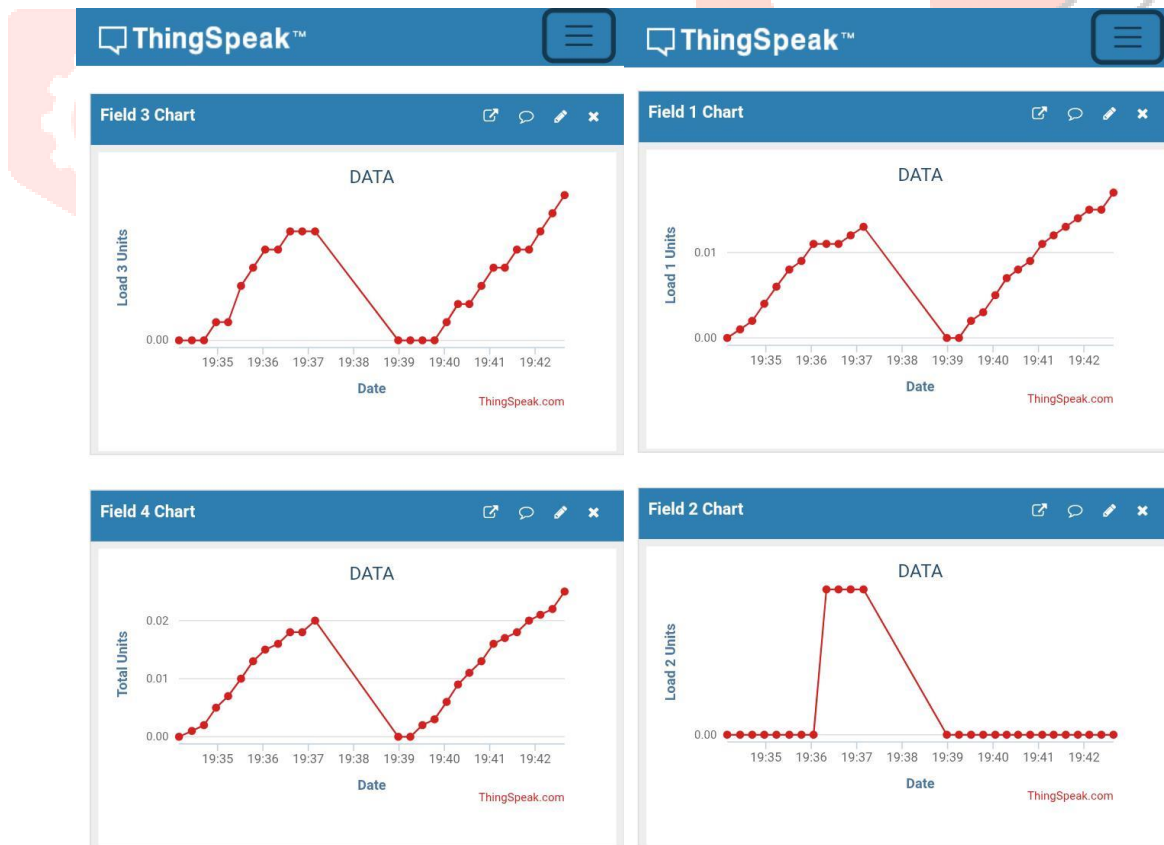

Figure 8: ThingSpeak cloud platform outputs

A comparison between the measured values and expected load consumption showed acceptable accuracy, with minor variations due to sensor tolerances and environmental conditions. The system demonstrated good repeatability and consistency during continuous operation.

The results confirm that the proposed system effectively integrates sensing, processing, and IoT communication for multi-load energy monitoring. It provides both local and remote access to energy data, improving usability and efficiency. Overall, the system proves to be a practical and cost-effective solution for real-time energy monitoring in residential and small-scale applications.

VIII. ADVANTAGES OF THE PROPOSED SYSTEM

- **Real-time monitoring** of individual and total energy consumption
- **Multi-load measurement** for better usage analysis
- **Remote access** through IoT cloud platform
- **Accurate sensing** using CT sensors
- **Low-cost and compact design**
- **User-friendly display** with 20×4 LCD
- **Energy efficiency** through usage insights
- **Data logging** for analysis and tracking

IX. CONCLUSION

This work presents the design and development of an IoT-based energy monitoring system using the Raspberry Pi Pico W. The system is capable of measuring and displaying energy consumption of multiple loads in real time, both individually and in total. The use of current sensors provides reliable measurements, while the 20×4 LCD enables clear and immediate local monitoring.

The integration of the ThingSpeak platform allows data to be accessed remotely, making it possible to track and analyze energy usage from any location. The system performed consistently during testing, with satisfactory accuracy and stable operation.

Overall, the proposed solution is simple, affordable, and effective for real-time energy monitoring. It is well suited for residential and small-scale applications and can be further enhanced to support more advanced energy management features in the future.

X. REFERENCES

- [1] P. Veerakumar, "Energy monitoring system to display on web page using ESP8266," *Indonesian Journal of Electrical Engineering and Computer Science*, vol. 9, no. 2, pp. 286–288, 2020.
- [2] A. J. Harvard Swart, "Cost effective remote energy monitoring using the ESP8266 NodeMCU," *International Journal of Recent Technology and Engineering (IJRTE)*, vol. 7, pp. 974–979, Mar. 2019.
- [3] N. Y. Dahlan, A. A. M. Aris, M. A. Saidin, M. J. M. Nadzeri, M. N. M. Nawi, W. F. Abbas, and P. Arshad, "Development of web-based real-time energy monitoring system for campus university," *Journal of Telecommunication, Electronic and Computer Engineering (JTEC)*, vol. 8, no. 10, pp. 157–164, 2016.
- [4] B. N. Rao and R. Sudheer, "Energy monitoring using IoT," in *Proc. Int. Conf. Inventive Computation Technologies (ICICT)*, 2020, pp. 868–872.
- [5] A. Salisu, A. Bugaje, and A. Z. Loko, "IoT based household electricity energy monitoring and control," *FUDMA Journal of Sciences*, vol. 4, no. 4, 2020.
- [6] S. Karthikeyan and P. T. V. Bhuvaneshwari, "IoT based real-time residential energy monitoring system," in *Proc. Trends in Industrial Measurement and Automation (TIMA)*, 2017, pp. 1–5.
- [7] M. Prathik, K. Anitha, and V. Anitha, "Smart energy monitoring using IoT," in *Proc. Int. Conf. Power, Energy, Control and Transmission Systems (ICPECTS)*, 2018, pp. 1–5.
- [8] W. Hlaing et al., "Implementation of WiFi-based single phase energy monitoring system for IoT," in *Proc. Int. Electrical Engineering Congress (iEECON)*, 2017, pp. 1–5.
- [9] B. Sahani et al., "IoT based smart energy monitoring system," *International Research Journal of Engineering and Technology (IRJET)*, vol. 4, no. 4, pp. 96–99, 2017.