



Transformer Fault Diagnosis Based on Multi-Class AdaBoost Algorithm

¹ Miss. Deepa Avinash Bisen ² Mr. Hirendra Hajare

¹ M.Tech. Scholar, ² Assistant Professor Computer Science & Engineering, Ballarpur Institute of Technology, India

Abstract : Transformer is one of the important components of the power system, capable of transmitting and distributing the electricity generated by renewable energy sources. Dissolved Gas Analysis (DGA) is one of the effective techniques to diagnose early faults in oil-immersed transformers. It correlates the concentration and ratio of dissolved gases with transformer faults. Researchers have proposed many methods for fault diagnosis, such as double ratio method, Rogers method, Duval triangle method, etc., but all of them have some problems. Based on the strong data mining capability and good robustness of AI techniques, many researchers introduced AI techniques to mine the features of DGA data. According to the characteristics and scale of DGA data, researchers select appropriate AI techniques or make appropriate improvements to AI techniques to improve diagnostic performance. This paper presents a systematic review of the literature on the application of artificial intelligence techniques for DGA-based diagnosis and for solving intractable problems in early transformer fault diagnosis, which include neural networks, clustering, support vector machines, etc. In addition to reviewing the applications of these intelligent techniques, the diagnostic thinking proposed in this literature, such as the introduction of temporal parameters for comprehensive analysis of DGA data and the extraction of optimal features for DGA data, is also reviewed. Finally, this paper summarizes and prospects the artificial intelligence techniques applied by researchers in transformer fault diagnosis.

KEYWORDS fault diagnosis, power transformer, artificial intelligence, data mining, dissolved gas analysis

1 Introduction

The combined use of renewable and conventional energy sources reduces the proportion of fossil energy (Long et al., 2022). For the power grid, renewable energy is beneficial to reduce greenhouse gas emissions, improve energy efficiency, and achieve clean, efficient, reliable and economic power supply. Large-scale main transformers and medium and low voltage distribution transformers are widely distributed and occupy important positions in the power grid. For the non-linear, uncertain and highly complex distribution network heavily penetrated by renewable energy, the safety and reliability of transformers become particularly important. Many researchers perform fault diagnosis of transformers in terms of short-circuit impedance, frequency response, and many other aspects. These methods are off-line diagnosis methods. Although the accuracy or sensitivity of these methods is high, they cannot detect early transformer faults in time and waste human and material resources. Therefore, the researchers conducted online monitoring of the oil of the transformer, analyzed the dissolved gas in the oil, and then diagnosed the early fault of the transformer, and monitored the status of the transformer in real time.

Dissolved Gas Analysis (DGA) is a very effective diagnostic strategy that is widely used to diagnose early faults in oil-immersed transformers. In order to accurately diagnose transformer faults, researchers have proposed several DGA methods, including the critical gas method, Orenburg ratio method, Rogers ratio method, IEC ratio method, Duval triangle method, etc. However, these methods have disadvantages such as coding defects, oversized coding boundaries, and critical value criterion defects, which affect the reliability of fault analysis. Each method has drawbacks, strict boundaries and hidden relationships .

Intelligence techniques have now been widely used in transformer fault diagnosis with convincing results. Unlike traditional methods, artificial intelligence methods simulate the survival and other behaviors of living beings to make decisions and optimize real problems, and the methods target more general problem descriptions, which are generally more lacking in structural information, and are applicable to solve complex problems like transformer fault diagnosis. Intelligent techniques help to resolve the uncertainty of traditional DGA methods due to boundary problems and unresolved codes or multi-fault scenarios. Researchers have applied many artificial intelligence techniques to DGA fault diagnosis, such as neural networks , support vector machine (SVM), and clustering. These techniques involve statistical machine learning, deep learning, etc. Statistical machine learning and deep learning are not only core issues in the field of artificial intelligence, but also one of the hot research directions in electrical engineering today. Researchers have applied these techniques not only to improve and enhance the DGA method only, but also to combine multiple techniques so as to enhance the robustness of the diagnosis method. In addition, researchers have also used intelligent techniques to mine the information in gas data and find the correlation between gas data and faults from them in order to detect early faults in transformers more accurately.

This study reviews artificial intelligence methods used to diagnose oil-immersed transformers in order to improve diagnostic performance of transformer and enhance the stability and reliability of operation. This paper introduces the intelligent techniques that should be used for fault diagnosis, and compares and analyzes these techniques. Some researchers have also done some reviews in this research topic. analyze the application of artificial neural networks, support vector machines, decision trees and plain Bayes in transformer fault diagnosis from the literature spanning 10 years. The authors point out that the development of new algorithms is necessary to improve diagnostic accuracy. review and summarize both traditional methods of DGA and DGA-based intelligence techniques and hope that future research in this area will not be limited to one diagnostic method. review the application of improved DGA method sin transformer fault diagnosis in terms of AI algorithms combined with DGA techniques, improvement of traditional DGA techniques, and statistical methods for DGA interpretation. The authors find that the visual graphical method is more effective in diagnosis compared to the traditional code method, but there is still room for improvement. Compared with these review articles, this paper highlights the following differences. First, this paper summarizes and analyzes more AI techniques, such as clustering, deep learning, and DS evidence theory. Second, this paper also summarizes the ideas of previous studies, such as the treatment of imbalanced data, the selection of the most optimal set of special features, the consideration of time as the key in formation ,and the avoidance of information loss due to dimensionality reduction as much as possible. In addition to the selection and improvement of diagnostic methods, the processing of data is also a very important part of transformer fault diagnosis. The framework for improving DGA performance with AI techniques is shown in **Figure 1**.

The paper is organized as follows: briefly discusses the traditional DGA method and its shortcomings, and shows the advantages of AI techniques that can compensate for the limitations of the traditional method. analyzes the application of various AI techniques in transformer fault diagnosis. Specifically, neural networks, support vector machines, clustering, deep learning, and other techniques are included. draws the conclusion, and the application of AI techniques in transformer fault diagnosis is prospected.

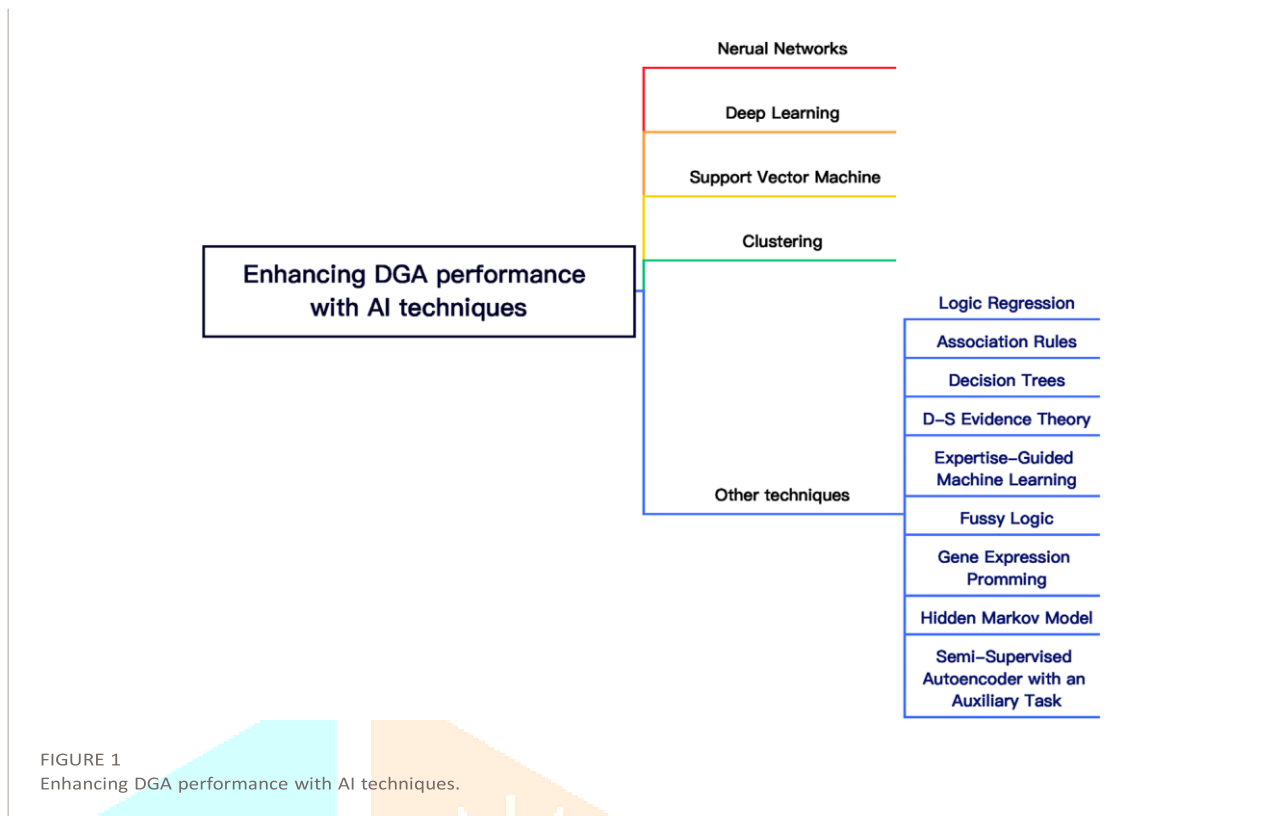

2 Enhancing dissolved gas analysis performance with appropriate improvements techniques

2.1 Neural networks

Neural networks can adequately approximate arbitrarily complex nonlinear relationships, and after learning from the initialized inputs and their relationships, it can also infer unknown relationships from unknown data, thus allowing the model to generalize and predicting known data. Many researchers have combined neural networks with DGAs, such as RBF neural networks, probabilistic neural networks (PNN), Elman neural networks, etc. Many researchers have also applied PNN to early fault diagnosis in transformers. However, the performance of PNN is largely influenced by the smoothing factor of its hidden layer elements, which can affect the classification performance combines CNN with DGA in order to accurately predict the type of faults in transformers at different noise levels, up to 20% for each level. The results show that CNNs are more immune to noise and have optimal performance compared to other intelligent techniques. In addition, different input ratios lead to different prediction accuracies. In order to further improve the diagnostic accuracy of DGA, researchers also combine several artificial intelligence methods so as to improve the robustness and diagnostic accuracy of the diagnostic model. Among them, to enhance the diagnostic performance of PNN, intelligent optimization algorithms such as bat algorithm (BA) and gray wolf optimizer (GWO) can be used to optimize the smoothing factor. combine BP neural network with improved Ada-boost algorithm, then combined with PNN neural network to form a series of diagnostic models for transformer faults, and finally combined with dissolved gas in oil analysis for transformer fault diagnosis. propose a new method with the lowest computational cost, using a genetic algorithm to optimize the ANN classifier, which is used to classify faults, replacing the traditional reinforcement learning (RL) action selection process with a genetic algorithm based optimizer. establish a combination of intelligent methods for transformer fault diagnosis evaluation and neural network case inference based on a knowledge base and an oil chromatography fault diagnosis case base. Through practical tests, this integrated method proved to be effective in diagnosing potential faults inside transformers, avoiding the disadvantages of misclassification or incomplete coding of the traditional three-ratio method, and improving the accuracy of transformer fault diagnosis to a certain extent. However, this method has not been validated for sudden faults, and future research is needed to analyze sudden faults of transformers.

2.2 Deep learning

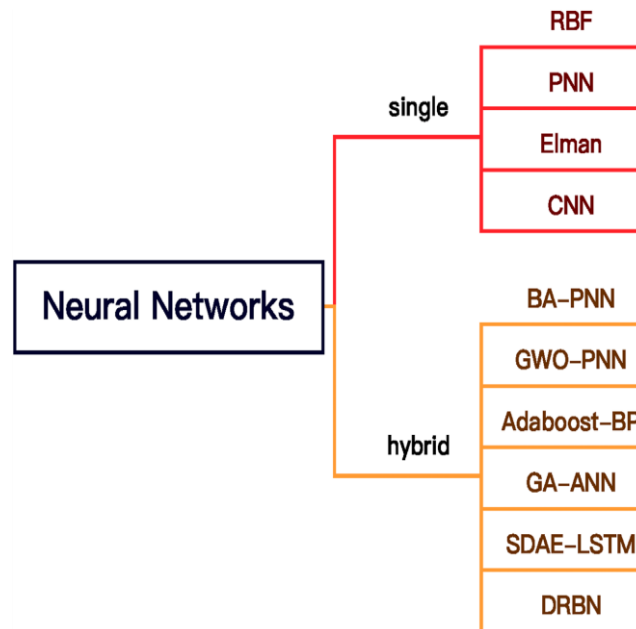

Deep learning was proposed by Geoffrey Hinton et al. at the University of Toronto in 2006, and it was introduced into machine learning to bring it closer to its original goal—artificial intelligence. Compared with “shallow learning” methods such as support vector machines, boosting, and maximum entropy methods, deep learning performs more layers of nonlinear operations and breaks the traditional neural network limit on the number of layers. The feature data learned by deep learning models are more intrinsically representative of the original data, which greatly facilitates classification and visualization problems. Therefore, deep learning is increasingly popular among researchers in the field of transformer fault diagnosis. combine deep confidence network (DBN), BP neural network, DGA triple ratio and eigen gas method and expert system to improve the reliability of diagnostic results and also demonstrated the feasibility and effectiveness of DBN for transformer fault diagnosis. use deep neural network (DNN) to identify the identified fault types of Duval triangles. The DNN achieved very high diagnostic accuracy compared to k-nearest neighbor (k-NN) algorithm and random forest algorithm for different data set sizes.

In addition to purely deep learning algorithms for transformer fault identification, researchers have proposed many diagnostic ideas. proposed a DBNbased DGA algorithm that automatically establishes a mapping relationship between the characteristic gas and the fault type. Different from the traditional data processing, the authors divided the DGA data into three categories: training data, finetuned data, and test data. For training data, the authors initialize the parameters of DBN by unsupervised learning. The fine-tuned data are used to fine-tune the parameters of the DBN. On the test data, DBN achieves good diagnostic accuracy. Compared with BP neural network, DBN has superior recognition accuracy and generalization ability. In practical situations, transformer fault data are not easy to collect, and thus the obtained data sets are usually unbalanced. Therefore, in order to solve the problem well and improve the recognition rate of fault types, many researchers have proposed some measures. use the boundary SMOTE method for oversampling, thus balancing the dataset. The DNN incorporating the boundary SMOTE method has the highest diagnostic accuracy compared to the traditional DGA method, artificial neural network, and DNN trained with unbalanced data. propose a one-dimensional convolutional neural network (1D CNN) model based on cost-sensitive learning, which focuses more on a small number of fault types. The cost matrix of this model was also optimized by a particle swarm algorithm in order to improve the diagnostic recognition rate. The final results show that the model is able to achieve the expected results with more accurate identification of the few classes, thus improving the identification accuracy of fault diagnosis. Obviously, processing for unbalanced data can achieve better results and is one of the hot spots of current research.

Figure 3 shows the framework diagram of deep learning based fault diagnosis methods.

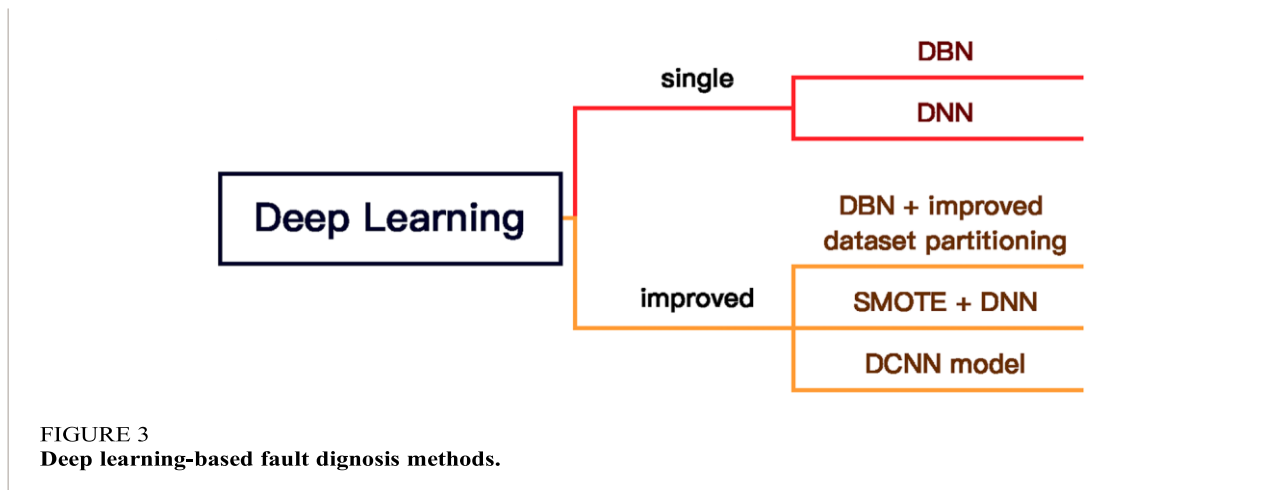

2.3 Support vector machine

Support vector machine (SVM) is also widely used in fault diagnosis to improve the accuracy of fault classification. SVM is an effective method to deal with large dimensionality of independent variables without recalculating from initial conditions to obtain new decision boundaries. However, the classification accuracy using a single SVM is not very high. Therefore, many researchers have combined other intelligent methods with SVMs to effectively improve the classification performance and achieve convincing results. propose an improved evolutionary particle swarm algorithm (Modified Evolutionary particle swarm optimization, MEPSO). EPSO combines particle swarm algorithm and evolutionary strategy by introducing variational operations that are able to preserve the superior properties of particles. In addition, the authors introduce the time varying acceleration coefficient (TVAC) based on EPSO to improve the robustness of the algorithm. Finally, the SVMMEPSO-TVAC method is obtained by mixing MEPSO with SVM. combine GA and SVM for optimizing parameters and selecting the best subset of features. The final results validate the robustness and generalization of the best feature subset selected by GA-SVM, thus verifying the availability and effectiveness of the best feature subset and GA-SVM. In addition, optimal diagnosis cannot be achieved by using a single class of features, and the introduction of some new features is necessary. point out that SVM can easily cause misclassification of samples distributed at decision boundaries, which leads to failure to accurately diagnose faults. Therefore, the authors combined GA, PSVM and fuzzy three ratio (FTR) method to determine whether the samples are at the decision boundary or not by using probabilistic approach to diagnose the samples that are not at the decision boundary. And the samples that are at the decision boundary are diagnosed using FTR. This method improves the accuracy of fault diagnosis and has strong robustness. In addition, researchers have also combined computational intelligence techniques such as bat algorithm (BA) and gray wolf algorithm with SVM to obtain transformer fault diagnosis models with good results.

It is known that the selection of the optimal set of features can improve the performance of fault identification. Many researchers have proposed methods to select a subset of features and establish intelligent algorithms to optimize SVM for transformer fault diagnosis models, which can improve the reliability and robustness of diagnosis. establish the genetic-algorithm-SVM-feature screen (GA-SVM-FS) model to screen out the hybrid DGA feature set. The accuracy of this feature set is 3–30% higher than the feature set formed by DGA gas or gas ratio. Then, the Improved Social Group Optimization-Support Vector Machine (ISGOSVM) Classifier was built for diagnosing transformer faults using OHFS as input, and compared with other models, the ISGOSVM Classifier achieved the best diagnostic accuracy compared to other models. propose a new intelligent diagnosis system for DGA, which is divided into a feature selection module and a fault diagnosis module, where the genetic algorithm-simulated annealing-SVM model is used for the feature selection module and the artificial bee colony-SVM model is used for the fault diagnosis. The results show that the method is reliable, and has a strong anti-interference capability. use GA-SVM model to select the

DGA feature set and optimized the parameters of SVM using Improved Krill Herd (IKH) Algorithm to establish IKHSVM fault diagnosis model. The results show that IKHSVM outperforms GASVM, BP neural network (BPNN) and PSOSVM.

In addition to algorithm improvement, the sample size of the transformer is also an aspect worth investigating. Different algorithms are applicable to data with different sample sizes. Choosing the appropriate algorithm according to the sample size can effectively improve the accuracy of transformer fault diagnosis. propose a transformer fault diagnosis method that divides the diagnosis process into two times. According to the size of the sample, multiple diagnostic models are used for the preliminary diagnosis, and then SVM is used for the secondary diagnosis. For the preliminary diagnosis, a combination of FA-GEP diagnostic model for large samples, SVM diagnostic model for small samples, and cloud object metamodel without creating samples as diagnostic models can effectively improve the diagnostic accuracy.

Many clustering algorithms are widely used in transformer fault diagnosis. Researchers apply clustering algorithms to DGA data or combine with other data to be able to classify transformer faults effectively. Fuzzy c-means clustering algorithm (FCM clustering algorithm) is a classical method of clustering, but the clustering accuracy for dissolved gas data is not high enough to classify transformer faults accurately . Therefore, propose a new exponential similarity function and affiliation function for FCM clustering, and the new affiliation function has no local extrema, which is beneficial to the classification of the algorithm. The improved FCM clustering can identify transformer faults well and classify DGA data accurately, and the clustering performance of FCM is also improved. Self Organizing Map (SOM) clustering can be used to classify early transformer faults and can reflect the severity of transformer faults. It can organize data spatially while maintaining topological relationships among data features, which is useful for analyzing high-dimensional data (e.g., DGA data). In addition, 60% of the training data is sufficient to train the SOM with good diagnostic accuracy compared to supervised learning methods such as SVM, which improves the diagnostic sensitivity of the SOM .

In addition to clustering algorithms alone, combining clustering algorithms with other intelligent techniques has been considered for transformer fault diagnosis. combine the k-Means Algorithm (KMA) with the k-Nearest neighbour (KNN) algorithm for the diagnosis of early transformer faults. The method first uses KMA to generate clusters and then uses the KNN algorithm to determine which clusters are closest to the unclassified dataset. The method is able to classify data that cannot be classified by Duval's triangle with an accuracy of 93%, which is an important addition to Duval's triangle. However, the method is still unable to classify dielectric and thermal hybrid faults effectively. propose a transformer anomaly detection method based on adaptive kernel fuzzy C-means clustering (KFCM) algorithm and kernel principal component analysis (KPCA). The method compares the projection of the old and new data and the change of the anomaly detection limit to determine whether there is an anomaly in the transformer according to the different operating states and the time lapse.

The framework diagram of the clustering methods applied by the researchers is shown in **Figure 5**.

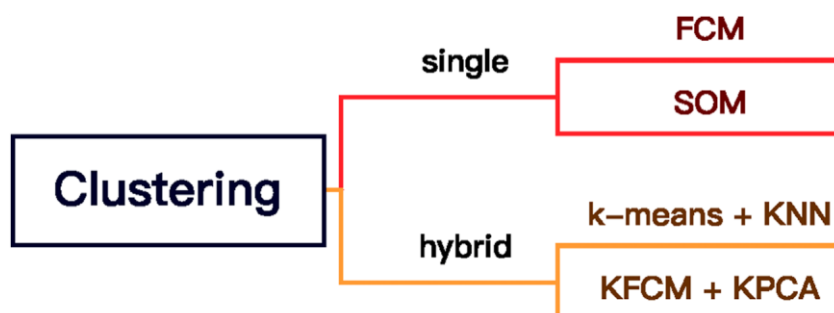

FIGURE 5
Clustering methods for fault diagnosis.

2.4 Other techniques

In addition to neural networks, SVM and clustering, researchers have also applied other AI techniques in fault diagnosis, such as logistic regression and association rules, with good results. Decision trees have also been widely used to improve the accuracy of fault diagnosis by using DGA data to enhance fault classification. Decision tree algorithms have been shown to be effective in processing DGA data of oil-immersed transformers, outperforming SVM, Bayesian algorithms, and neural networks in terms of diagnostic performance. In addition, applying the decision tree algorithm to the KNIME platform greatly reduces the time spent compared to MATLAB. The transformer fault diagnosis model based on the improved KNN algorithm and decision tree proposed by improves the number of neighbors and the type of distance of the KNN algorithm, thus improving the diagnostic accuracy of the model, with a final accuracy of 93.75%. Although combining the KNN algorithm with the decision tree principle has good robustness, the performance of the method is very dependent on the type of distance, the number of neighbors, and how to combine the responses of the neighbors.

D-Evidence Theory (DET) is an information fusion method that has the ability to handle uncertain information. Compared with Bayesian theory, DET does not need to know the prior probability and can represent “uncertainty” well, so it is widely used to deal with uncertain data. The transformer fault diagnosis problem can be viewed as a multi-attribute decision problem, so DET is well suited to solve this problem. However, when there is a high degree of conflicting evidence, it falls into Zadeh’s paradox and cannot reasonably assign Basic Probability Assignment (BPA) to the conflicting quantities. To address this problem, researchers have introduced DS evidence theory with appropriate improvements so that it can be used to accurately diagnose potential transformer failures and avoid misdiagnosis as much as possible. Introduce weight coefficients to readjust the BPA to obtain the Improved D-S Evidence Theory (IDET), thus avoiding the difficulty in resolving conflicting evidence. In addition, to enrich the information sources and improve the accuracy of diagnosis, before using DET for the final diagnosis, the introduction of hypersphere multiclass support vector machine (HMSVM), hybrid immune algorithm (HIA) and kernel extreme learning machine (KELM) for preliminary diagnosis of DGA data, and if the diagnosis results are consistent, the results are output directly. Otherwise, the diagnostic models of the three models need to be used as input and IDET is used for comprehensive diagnosis to obtain the final diagnostic results. The results show that the diagnostic accuracy of HMSVM is higher compared with HIA and KELM. IDET overcomes the problem of high conflict among evidences, and the diagnostic accuracy of using it to fuse multiple data sources is higher than 94%, which is better than that of a single method.

Fuzzy logic has also been used by researchers in DGA fault diagnosis. Fuzzy logic can be used to diagnose the severity of faults and provide guidance to technicians to measure the overall condition of the transformer so that reasonable maintenance measures can be developed to prevent faults from occurring. DGA algorithms to identify transformer faults and their severity. The fuzzy logic allows the calculation of the fault index percentage, a parameter that gives a good indication of the severity of transformer faults. However, the performance of pure fuzzy logic is not very good. Fuse fuzzy theory with reinforcement learning (RL) as a classifier for early transformer faults. For accurate classification, the most appropriate variables are selected as input to the fuzzy RL classifier using J48 algorithm for DGA data. The experimental results show that the fuzzy RL classifier achieves 99.7% fault identification accuracy, which is significantly better than other soft computing methods.

Use Gene Expression Programming (GEP) for DGA fault diagnosis, which is widely used for data classification problems. The performance of DGA data processed with this method is much better than IEC/IEEE, fuzzy logic, ANN, and SVM methods. However, the accuracy of the GEP model for diagnosis suffers when detecting multiple faults, and using more DGA data for training cannot prove this situation.

As analyzed in the previous paper, time is also one of the important information for transformer fault diagnosis, because dissolved gas in oil changes with time, and if this factor of time is ignored, then part of the information for fault diagnosis will be lost. State that Hidden Markov Model (HMM) is a suitable solution for

time-dependent modeling. Solving the transfer probabilities of different health conditions by HMM enables short-term prediction of transformer faults.

In industry, visual inspection to diagnose early faults in transformers requires huge costs, and therefore, most DGA data are unlabeled. To deal with this sparse labeled data, use SOM to perform dimensionality reduction and to cluster adjacent data. However, point out that dimensionality reduction leads to the loss of key information, while clustering does not guarantee the correlation between high-level features. Therefore, a semi-supervised autoencoder with an auxiliary task (SAAT) is proposed for DGA fault diagnosis. semi-supervised autoencoder (SSAE) generates a 2D health SAAT is an auxiliary detection task inserted in the loss function of SSAE to detect faults and normal states and to visualize health degradation features. In addition, the model does not require additional dimensionality reduction and allows direct visualization of high-level features in 2D. Experimental results show that SAAT outperforms principal component analysis, sparse autoencoder (SAE), and deep belief network (DBN) in terms of health degradation performance results by being above 90% in all metrics of fault detection and identification.

Conclusion

This paper reviews the application of artificial intelligence techniques in transformer DGA fault diagnosis. Artificial intelligence techniques diagnose faults by mining the relationship that exists between dissolved gases in oil and transformer faults. Researchers have proposed various diagnostic methods from different aspects to improve the accuracy of fault diagnosis. Among them, many researchers improve the existing intelligent algorithms by adjusting a certain part of the algorithm or combining the corresponding strategies of other intelligent algorithms so as to enhance the robustness of the algorithm. Although this can improve the accuracy of fault diagnosis, it does not do much work on analyzing DGA data and is not targeted enough. Some researchers have been able to effectively improve fault identification performance by selecting appropriate algorithms based on the size of the DGA data. In addition, researchers also found that time plays an important role in DGA fault diagnosis because dissolved gas in oil changes with time, and ignoring the factor of time can lead to loss of information. Therefore, researchers have adopted LSTM, DRBN, HMM, which can analyze time series for fault diagnosis, so as to effectively extract fault features or overcome “time-shift” errors. Artificial intelligence methods have strong data mining capability, but for classification problems, when a new fault appears, artificial intelligence methods will classify the new fault with existing faults based on previous experience data, which will lead to a decrease in diagnostic accuracy. In addition, the DGA data does not fully reflect the transformer status, and it needs to be combined with new monitoring data for a more effective fault diagnosis of the transformer.

References

1. Abu-Siada, A. (2019). Improved consistent interpretation approach of fault type within power transformers using dissolved gas analysis and gene expression programming. *Energies* 12, 730. doi:10.3390/en12040730
2. Almoallem, Y. D., Taha, I. B. M., Mosaad, M. I., Nahma, L., and Abu-Siada, A. (2021). Application of logistic regression algorithm in the interpretation of dissolved gas analysis for power transformers. *Electronics* 10, 1206. doi:10.3390/electronics10101206
3. Benmahamed, Y., Kherif, O., Teguvar, M., Boubakeur, A., and Ghoneim, S. S. M. (2021). Accuracy improvement of transformer faults diagnostic based on dga data using svm-ba classifier. *Energies* 14, 2970. doi:10.3390/en14102970
4. Cui, Q., Kai, L., Gao, H., Chen, G., and Xu, M. (2016). “Research of the transformer fault diagnosis expert system based on esta and deep learning neural network programmed in matlab,” in 2016 International Conference on Civil, Transportation and Environment, Guangzhou, China, January 30–31, 2016 (Atlantis Press), 772–778. doi:10.2991/iccte-16.2016.132
5. Duan, H., and Liu, D. (2011). “Application of improved elman neural network based on fuzzy input for fault diagnosis in oil-filled power transformers,” in 2011 International Conference on Mechatronic Science, Electric Engineering and Computer (MEC), Jilin, China, August 19–21, 2011 (IEEE), 28–31. doi:10.1109/mec.2011.6025393
6. doi:10.1109/mec.2011.6025393

7. Fang, J., Zheng, H., Liu, J., Zhao, J., Zhang, Y., and Wang, K. (2018). A transformer fault diagnosis model using an optimal hybrid dissolved gas analysis features subset with improved social group optimization-support vector machine classifier. *Energies* 11, 1922. doi:10.3390/en11081922
8. Fu, X., Guo, Q., and Sun, H. (2020). Statistical machine learning model for stochastic optimal planning of distribution networks considering a dynamic correlation and dimension reduction. *IEEE Trans. Smart Grid* 11, 2904–2917. doi:10.1109/tsg.2020.2974021
9. Fu, X. (2022). Statistical machine learning model for capacitor planning considering uncertainties in photovoltaic power. *Prot. Control Mod. Power Syst.* 7, 5–13. doi:10.1186/s41601-022-00228-z
10. Ge, C. H., Cui, H. Y., Huo, S. J., Guo, W. C., and Qin, L. M. (2018). “Improved dga methods of power Transformer Fault diagnosis: A review,” in 2018 7th International Conference on Energy and Environmental Protection (ICEEP 2018) (Atlantis Press), 1765–1768. doi:10.2991/iceep-18.2018.321
11. Han, Y., Zhao, D., and Hou, H. (2016). Oil-immersed transformer internal thermoelectric potential fault diagnosis based on decision-tree of knime platform. *Procedia Comput. Sci.* 83, 1321–1326. doi:10.1016/j.procs.2016.04.275
12. Huang, X., Zhang, Y., Liu, J., Zheng, H., and Wang, K. (2018). A novel fault diagnosis system on polymer insulation of power transformers based on 3-stage ga-sa-svm ofc selection and abc-svm classifier. *Polymers* 10, 1096. doi:10.3390/polym10101096
13. 09
14. Illias, H. A., and Liang, Z. W. (2018). Identification of transformer fault based on dissolved gas analysis using hybrid support vector machinemodified evolutionary particle swarm optimisation. *Plos One* 13, e0191366. doi:10.1371/journal.pone.0191366
15. Islam, M. M., Lee, G., and Hettiwatte, S. N. (2017). A nearest neighbour clustering approach for incipient fault diagnosis of power transformers. *Electr. Eng.* 99, 1109–1119. doi:10.1007/s00202-016-0481-3
16. Jiang, J., Chen, R., Chen, M., Wang, W., and Zhang, C. (2019). Dynamic fault prediction of power transformers based on hidden markov model of dissolved gases analysis. *IEEE Trans. Power Deliv.* 34, 1393–1400. doi:10.1109/tpwr.2019.2900543
17. Kari, T., Gao, W., Zhao, D., Abiderexiti, K., Mo, W., Wang, Y., et al. (2018). Hybrid feature selection approach for power transformer fault diagnosis based on support vector machine and genetic algorithm. *IET Gener. Transm. Distrib.* 12, 5672–5680. doi:10.1049/iet-gtd.2018.5482
18. Kherif, O., Benmahamed, Y., Tegar, M., Boubakeur, A., and Ghoneim, S. S. M. (2021). Accuracy improvement of power transformer faults diagnostic using knn classifier with decision tree principle. *IEEE Access* 9, 81693–81701. doi:10.1109/access.2021.3086135
19. Kim, Y., Park, T., Kim, S., Kwak, N., and Kweon, D. (2019). Artificial intelligent fault diagnostic method for power transformers using a new classification system of faults. *J. Electr. Eng. Technol.* 14, 825–831. doi:10.1007/s42835-019-00105-0
20. Kim, S., Jo, S. H., Kim, W., Park, J., Youn, B. D., Han, Y., et al. (2020). A semi-supervised autoencoder with an auxiliary task (saat) for power transformer fault diagnosis using dissolved gas analysis. *IEEE Access* 8, 178295–178310. doi:10.1109/access.2020.3027830
21. Lee, L., Xie, L., Zhang, D., Yu, B., Ge, Y., and Lin, F. (2013). Condition assessment of power transformers using a synthetic analysis method based on association rule and variable weight coefficients. *IEEE Trans. Dielectr. Electr. Insul.* 20, 2052–2060. doi:10.1109/tdei.2013.6678853
22. Li, E., Wang, L., Song, B., and Jian, S. (2018). Improved fuzzy c-means clustering for transformer fault diagnosis using dissolved gas analysis data. *Energies* 11, 2344. doi:10.3390/en11092344
23. doi:10.3390/en11092344
24. Liang, Y., Xu, Y. Y., Wan, X. S., Li, Y., Liu, N., and Zhang, G. J. (2018). “Dissolved gas analysis of transformer oil based on deep belief networks,” in 2018 12th International Conference on the Properties and Applications of Dielectric Materials (ICPADM), Xi’an, China, May 20–24, 2018 (IEEE), 825–828. doi:10.1109/icpadm.2018.8401156
25. Long, H., Fu, X., Kong, W., Chen, H., Zhou, Y., and Yang, F. (2022). Key technologies and applications of rural energy internet in China. *Inf. Process. Agric.* doi:10.1016/j.inpa.2022.03.001
26. Lopes, S. M. D. A., Flauzino, R. A., and Altafim, R. (2021). Incipient fault diagnosis in power transformers by data-driven models with over-sampled dataset. *Electr. Power Syst. Res.* 201, 107519. doi:10.1016/j.epsr.2021.107519
27. *Electr. Power Syst. Res.* 201, 107519. doi:10.1016/j.epsr.2021.107519
28. Luo, Z., Zhang, Z., Yan, X., Qin, J., Gao, Z., Wang, H., et al. (2020). Dissolved gas analysis of insulating oil in electric power transformers: A case study using sdaelstm. *Math. Probl. Eng.* 2020, 1–10. doi:10.1155/2020/2420456

29. Malik, H., and Mishra, S. (2016). Application of gene expression programming (gep) in power transformers fault diagnosis using dga. *IEEE Trans. Ind. Appl.* 52, 4556–4565. doi:10.1109/34084poweri.2014.7117782
30. Malik, H., Sharma, R., and Mishra, S. (2020). Fuzzy reinforcement learning based intelligent classifier for power transformer faults. *ISA Trans.* 101, 390–398. doi:10.1016/j.isatra.2020.01.016
31. Mehdipourpicha, H., Bo, R., Chen, H., Rana, M. M., and Hu, F. (2019). “Transformer fault diagnosis using deep neural network,” in 2019 IEEE Innovative
32. Smart Grid Technologies - Asia (ISGT Asia), Chengdu, China, May 21–24, 2019 (IEEE), 4241–4245. doi:10.1109/isgt-asia.2019.8881052
33. Mi, X., Subramani, G., and Chan, M. (2021). “The application of rbf neural network optimized by k-means and genetic-backpropagation in fault diagnosis of power transformer,” in E3S Web of Conferences, Bogor, Indonesia, July 6–7, 2021 (EDP Sciences), 03002. doi:10.1051/e3sconf/202124203002
34. Misbahulmunir, S., Ramachandaramurthy, V. K., and Thayoob, Y. H. M. D. (2020). Improved self-organizing map clustering of power transformer dissolved gas analysis using inputs pre-processing. *IEEE Access* 8, 71798–71811. doi:10.1109/access.2020.2986726
35. Poonnoy, N., Suwanasri, C., and Suwanasri, T. (2021). Fuzzy logic approach to dissolved gas analysis for power transformer failure index and fault identification. *Energies* 14, 36. doi:10.3390/en14010036
36. Qi, B., Wang, Y., Zhang, P., Li, C., and Wang, H. (2019). A novel deep recurrent belief network model for trend prediction of transformer dga data. *IEEE Access* 7, 80069–80078. doi:10.1109/access.2019.2923063
37. Ravi, N. N., Drus, S. M., and Krishnan, P. S. (2019). “Data mining techniques for transformer failure prediction model: A systematic literature review,” in 2019 IEEE 9th Symposium on Computer Applications & Industrial Electronics (ISCAIE), Kota Kinabalu, Malaysia, April 27–28, 2019 (IEEE), 305–309. doi:10.1109/iscaie.2019.8743987
38. Shang, H., Xu, J., Zheng, Z., Qi, B., and Zhang, L. (2019). A novel fault diagnosis method for power transformer based on dissolved gas analysis using hypersphere multiclass support vector machine and improved d–s evidence theory. *Energies* 12, 4017. doi:10.3390/en12204017
39. Taha, I. B. M., Ibrahim, S., and Mansour, D. E. A. (2021). Power transformer fault diagnosis based on dga using a convolutional neural network with noise in measurements. *IEEE Access* 9, 111162–111170. doi:10.1109/access.2021.3102415
40. Taneja, M. S., Pandey, K., and Sehrawat, S. (2016). “A review on prognosis and diagnosis of transformer oil quality using intelligent techniques based on dissolved gas analysis,” in 2016 7th India International Conference on Power Electronics (IICPE), Patiala, India, November 17–19, 2016 (IEEE), 1–6. doi:10.1109/iicpe.2016.8079419
41. Tang, K., Liu, T., Xi, X., Yue, L., and Zhao, J. (2018). “Power transformer anomaly detection based on adaptive kernel fuzzy c-means clustering and kernel principal component analysis,” in 2018 Australian & New Zealand Control Conference (ANZCC), Melbourne, Australia, December 7–April 8, 2018 (IEEE), 318–323. doi:10.1109/anzcc.2018.8606615.10