



## Contactless EV Charging System

<sup>1</sup>Sangram Patil, <sup>2</sup>Simran Mulla, <sup>3</sup>Poonam Bhore, <sup>4</sup>Vaishnavi Khandekar, <sup>5</sup>D. B. Kadam

<sup>5</sup>Professor, Electronics & Telecommunication Department, P.V.P.I.T, Sangli, Maharashtra, India

<sup>1234</sup>Student, Electronics & Telecommunication Department, P.V.P.I.T, Sangli, Maharashtra, India

### **Abstract:**

This project report explores the development of a contactless EV charging system in static mode. The system aims to provide a convenient and efficient way to charge electric vehicles without the need for physical connections. The report discusses the design and implementation of the system, including the use of wireless charging technology and smart grid integration. The project also evaluates the performance and reliability of the contactless EV charging system in static mode. Overall, this report provides valuable insights into the potential benefits and challenges of contactless EV charging technology for future transportation infrastructure. Contactless electric vehicle (EV) charging system in static mode would typically describe the key features and functionality of the system without going into specific technical details. Here is an example of an abstract for a contactless EV charging system in static mode "Contactless electric vehicle (EV) charging systems have emerged as a convenient and efficient solution for powering EVs without the need for physical connections. This report presents a novel contactless EV charging system designed for static mode operation, where EVs can be charged wirelessly while stationary.

**Keywords:** EV charging, Static, batteries

### **I. INTRODUCTION**

The Demand of Electricity is increasing day by day as the population of world is increasing. So use of electricity efficiently and in controlled manner has become the most important aspect of today's power system. Most of the power system uses wired transmission of power and loss occurred due to this is enormously high about 30% of the total loss in power is just because of wired power transmission and distribution. The main reason behind this loss is the resistance of wires during transmission. The efficiency of wired transmission can be improved composite overhead conductors and underground cables that use high temperature super conductor. But the transmission is still inefficient. India's electricity grid has highest percentage of losses in the world. wireless power transfer can be effective option to curb these losses as wireless power transfer uses wireless mode of transmission. Electricity theft has also become an crucial factor. In India losses due to power theft are increasing rapidly and wired transmission somehow helping power theft as wired transmission is more vulnerable to power theft. in addition to losses, wastage of electricity is a big concern in power system. As per recent survey of government of India waste of electricity is high 8 % to be precise. Electricity wastage sources include home appliances, government offices, street light systems, transport facilities. as sources like home appliances and government offices are subjected to human mentality we can't control the wastage of electricity using technical knowledge as they need awareness more than technical expertise but we can control the wastage which occurs through street lights and other transportation facilities many methods have been developed over the years to curb the leakage and wastage of electricity through the transport facilities like solar power based street lights and traffic systems but still they are not able to provide an effective solution as they are irregular and subjected to environmental conditions. Technical knowledge as they need awareness more than technical expertises but we can control the wastage which occurs through street lights and other transportation facilities many methods have been developed over the years to systems but still they are not able to provide an effective solution as they are irregular and subjected to environmental

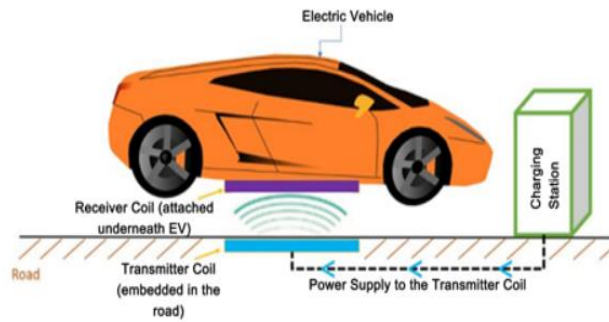

Fig 1. Use of static wireless power transfer using a probe in our country.

## II. THEORITICAL BACKGROUND

Basic principle of wireless charging is same as transformer working principle. In wireless charging there are transmitter and receiver, 220V 50Hz AC supply is converted into low voltage, High frequency alternating current and this high frequency AC is supplied to transmitter coil, then it creates alternating magnetic field that cuts the receiver coil and causes the production of AC power output in receiver coil. Then finally, this AC power at receiver side rectified to DC and fed to the battery to charge battery effectively. Here we implement static wireless charging stations. Here vehicle get charged while it is n parking . The power transfers over the air from a stationary transmitter to the receiver coil in a stationary vehicle. It reduces the need for large energy storage which further reduces the weight of the vehicle. Inductive Wireless Charging System (IWC) :- The basic principle of IWC is Faraday's law of induction. Here wireless transmission of power is achieved by mutual induction of magnetic field between transmitter and receiver coil. When the main AC supply applied to the transmitter coil, it creates AC magnetic field that passes through receiver coil and this magnetic field moves electrons in receiver coil causes AC power output. This AC output is rectified and filtered to Charge the EV's energy storage system. The amount of power transferred depends on frequency, mutual inductance and distance between transmitter and receiver coil. The basic principle of IWC is Faraday's law of electromagnetic induction. Here wireless transmission of power is achieved by mutual induction of magnetic field between transmitter and receiver coil. When the main AC supply applied to the transmitter coil, it creates AC magnetic field that passes through receiver coil and this magnetic field moves electrons in receiver coil causes AC power output. This AC output is rectified and filtered to Charge the EV's energy storage system. The amount of power transferred depends on frequency, mutual inductance and distance between transmitter and receiver coil.

The system will work in two modes A. EV charging station contactless to vehicle battery vehicle to grid AC supply conversion using VSI. A. Ev charging station is incorporated with solar photo voltaic array and ac grid, ac supply is converted to dc then as per solar power and grid power availability power is contactless transferred to EV battery to be charged vehicle to grid

Dc supply for Ev battery is converted to AC 230v single phase using VSI unit and is transferred to grid. VSI unit will have H-BRIDGE INVERTER with SPWM technique.

PHASES:

Phase1: study of Ev charging station.

Phase2: implementation of Pv mppt based charging unit.

Phase3: implementation of grid charging unit.

Phase4: implementation of contactless unit.

Phase5: implementation of vehicle to grid unit.

Phase6: results, analysis and report writing

Technical description:

The wireless energy charger is composed of two independent parts: the transmitter and the receiver which are linked together by a magnetic field.

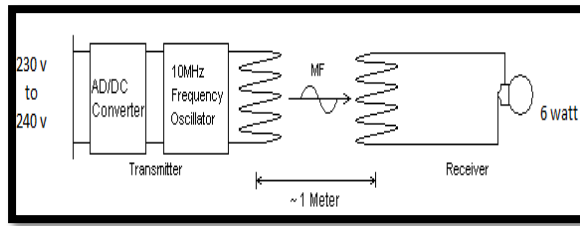

Figure 2: Wireless Energy Charger

The transmitter will receive a 230 V AC and will be composed of an ac/dc converter, a frequency oscillator and a copper coil.

AC to DC converter:

This converter will convert the 230 V AC from the power outlet to a 18 V DC voltage across the input of the frequency oscillator. This converter is basically a rectifier circuit composed a diode network and a capacitor.

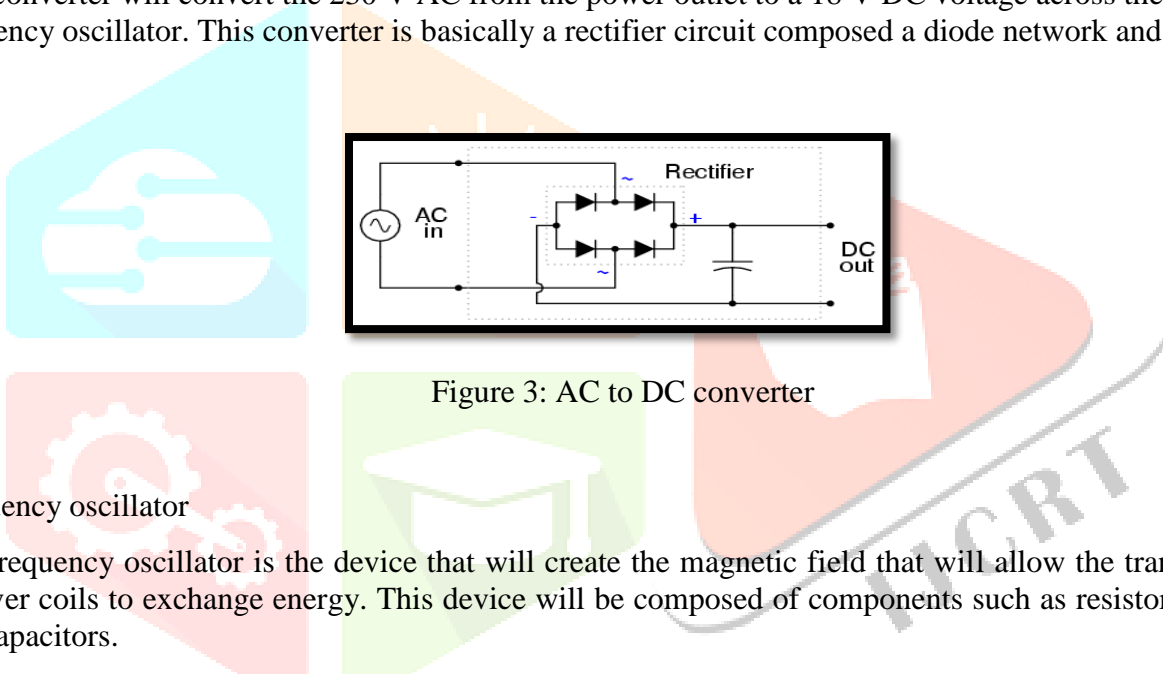

Figure 3: AC to DC converter

Frequency oscillator

The frequency oscillator is the device that will create the magnetic field that will allow the transmitter and receiver coils to exchange energy. This device will be composed of components such as resistors, inductors and capacitors.

In order to achieve a resonance frequency in the oscillator circuit the inductive reactance and the capacitive reactance of the resonator coil will equal such that:

$$\omega L = \frac{1}{\omega C} \rightarrow L = \frac{1}{C} \tag{eq 1}$$

Where:  $\omega = 2\pi * f$  ,  $L$  is the inductance in ‘Henry’

And  $C$  the capacitance in ‘Farad’

In other word the resonance frequency that will allow us to initiate the wireless power transfer from the transmitter and receiver coils will be calculated using the values of the inductance and capacitance of the coils in the following formula.

$$f = \frac{1}{\sqrt{LC}} \tag{eq 2}$$

2)

Where:  $f$  is the resonance frequency in ‘Hertz’

When current starts to flow in the first coil loops, electric (E) and magnetic (B) fields are created. The turns in the loops acts as capacitor as the circulating current deposits positive and negative charges and an electric field is generated. On the other hand, the magnetic field is generated all along each loop and strengthens with an increase in number of turns of the coil. By making the gap between the turns small in the 2 cm, the E-field will be weak and therefore restricted near the transmitting coil. By having more number of turns in the range of 30, the B-field will be strong enough to reach the receiving coil. The reason why the focus is on the B-field is because its strength is easily adjustable by varying the number of turns or the intensity of the current. In other word, an increase in either of these parameters will result in an increase in the magnetic field.

The magnitude of the B-field can be calculated the following formula:

$$B = \mu \frac{N}{l} I \tag{eq}$$

3)

in Tesla, where N= number of turns,  $l$  = length of coil, I= current in Amps

And  $\mu$  = permeability of free space

The electric (E) and magnetic (B) fields are energy carrying wave and their energy densities can be calculated as follows:

$$W_E = \frac{1}{2} \epsilon E^2 \tag{eq}$$

4)

where  $\epsilon$  = permittivity of free space.

$$W_B = \frac{1}{2} \frac{B^2}{\mu} \tag{eq}$$

5)

and  $\mu$  = permeability of free space

When the energy carrying B-field strikes the receiving coil, it induces a voltage or an emf (electromotive force) which supplies power to the load and is given by:

$$V = -N \frac{d\phi}{dt} \tag{eq}$$

6)

where  $\phi$  = flux=  $B * A$  with  $A$  =area of the coil.

**I. PROPOSED METHODOLOGY**

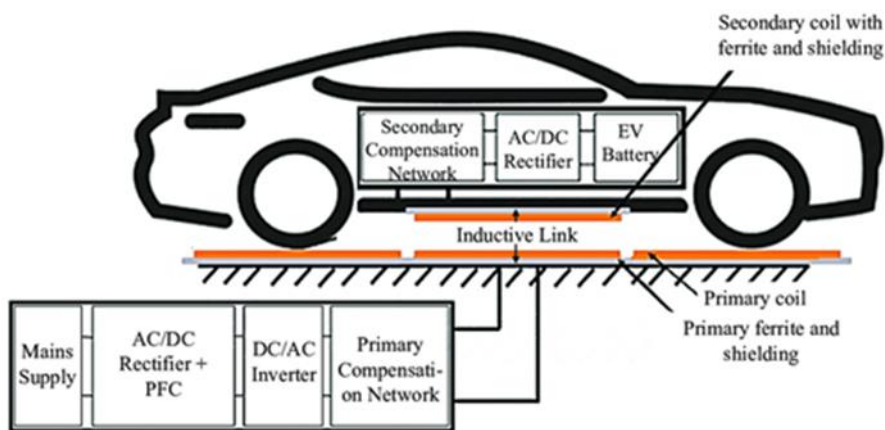

Fig 4 -Construction of contactless EV charging system

### Transmission Station Pad:

- **Base:** This is the physical structure that supports and houses the coil and other components. It can be made of durable materials like concrete or composite materials to handle traffic and weather conditions.
- **Primary Coil:** This is a copper coil with multiple windings. The alternating current (AC) from the power grid runs through this coil.
- **Magnetic Field Generator:** The AC current creates a magnetic field when it flows through the primary coil.
- **Power Electronics:** This unit regulates the AC power from the grid to ensure it matches the requirements for efficient wireless energy transfer and safety.
- **Control Unit:** This unit manages the overall system operation, including communication with the vehicle and safety features.

### Receiver Pad (In-Vehicle):

- **Secondary Coil:** Similar to the primary coil, this coil is also made of copper with windings. It sits under the car and interacts with the magnetic field from the ground station pad.
- **Rectifier:** This component converts the AC current received from the magnetic field into DC current.
- **Voltage Regulator:** This unit ensures the DC voltage reaching the battery is at the appropriate level for safe and efficient charging.

### Additional considerations:

- **Alignment Mechanisms:** Some systems might incorporate mechanisms to guide the driver for proper vehicle positioning over the charging pad.
- **Cooling System:** Wireless energy transfer can generate heat. The system may include heat sinks or fans for proper thermal management.
- **Safety Features:** The system should have safeguards to prevent overheating, electromagnetic interference, and foreign object detection for safe operation.

### Working of Contactless EV charging System

#### First phase : Converter of DC to AC:-

Inverters are the circuit which converting the DC to AC. We could easily say that the transfers of inverter power from the source of DC to an AC load. When only a voltage of DC source is available, the aim is to generate an voltage of AC. By adjusting the dc of input voltage or also keeping the gain of the constant inverter, a output variable voltage could b obtained. On the next hand, if the voltage of DC is not controllable and set , a variable voltage output could be obtained by adjusting the gain of inverter, which is usually achieved by PWM ( Modulation of pulse width) control inside the inverter. The gain inverter could be defining as this ratio of voltage of AC output to the voltage of DC input. Modified inverter of sine wave emulates a sine wave. It introduces a dead time in a normal square wave output. The wave is produced by switching the DC source in the 3 values at frequencies of set thus produces fewer harmonics than square wave. it providing easy and cheap solution of device po powering that using power of AC. Its main drawbacks are that not to whole device that aren't resistant to signal distortion like medical equipment and computers properly works on it. It is noting the modified inverter of Sine wave are not rated for THD (distortion of Total harmonic). It would be useless to rate a modified inverter of sine wave for distortion of harmonic, because its intended use is not to reduce the introduced harmonics to the device. Their aims is providing inexpensive or also AC power of portable. An efficiency topic is brought up to the harmonics discussion. Pure sinus wave of inverters are 5 percent low efficient, but the rating varies from the energy battery conversion to adjusted sinus wave of output. This doesn't taking into the effect consideration of harmonics on battery to the instrument performance quality. In the sine wave of modified, the frequency of high harmonic contents producing the enhanced interference radio, more the heat effect in microwaves/ motors or also overload producing because to the reduction of capacitor impedance for the less frequency of capacitors/filters for the improvement of the factor



of power. In terms of energy conservation of battery, a pure inverter of sine wave may be low efficiently, but this loads uses more of energy output.

A bidirectional single-phase ac/dc converter is usually utilized as the interface between DERs and the ac grid system to deliver power flows bi-directionally and maintains good ac current shaping and dc voltage regulation, as shown in Fig Good current shaping can avoid harmonic pollution in an ac grid system, and good dc voltage regulation can provide a high-quality dc load.

To achieve bidirectional power flows in a renewable energy system, a PWM strategy may be applied for the single-phase full-bridge converter to accomplish current shaping at the ac side and voltage regulation at the dc side. Generally, BPWM and UPWM strategies are often utilized in a single-phase ac/dc converter. In this paper, a novel simplified PWM strategy is proposed. The proposed simplified PWM only changes one active switch status in the switching period to achieve both charging and discharging of the ac side inductor current. Therefore, the proposed simplified PWM strategy reduces the switching losses and also provides high conversion efficiency.

### Voltage Multiplier

The voltage multiplier is an electronic circuit that delivers the output voltage whose amplitude (peak value) is two, three, or more times greater than the amplitude (peak value) of the input voltage.

What is voltage multiplier?

Voltage multiplier power supplies have been used for many years. Walton and Cockroft built an 800 kV supply for an ion accelerator in 1932. Since that time the voltage multiplier has been used primarily when high voltages and low currents are required. The use of voltage multiplier circuits reduces the size of the high voltage transformer and, in some cases, makes it possible to eliminate the transformer.

The recent technological developments have made it possible to design a voltage multiplier that efficiently converts the low AC voltage into high DC voltage comparable to that of the more conventional transformer-rectifier-filter-circuit.

The voltage multiplier is made up of capacitors and diodes that are connected in different configurations.

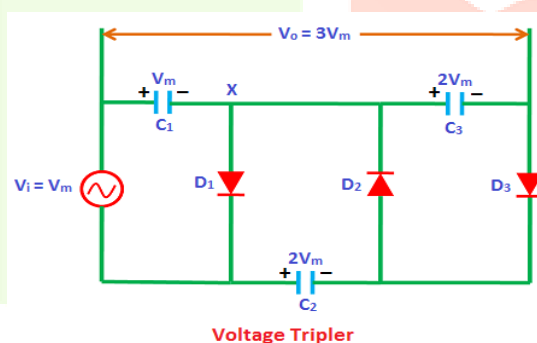

Fig Voltage multiplier Voltage multiplier

The voltage tripler can be obtained by adding one more diode-capacitor stage to the half-wave voltage doubler circuit.

During first positive half cycle:

During the first positive half cycle of the input AC signal, the diode D1 is forward biased whereas diodes D2 and D3 are reverse biased. Hence, the diode D1 allows electric current through it. This current will flow to the capacitor C1 and charges it to the peak value of the input voltage I.e.  $V_m$ .

During negative half cycle:

During the negative half cycle, diode D2 is forward biased whereas diodes D1 and D3 are reverse biased. Hence, the diode D2 allows electric current through it. This current will flows to the capacitor C2 and charges it. The capacitor C2 is charged to twice the peak voltage of the input signal ( $2V_m$ ). This is because the charge ( $V_m$ ) stored in the capacitor C1 is discharged during the negative half cycle.

Therefore, the capacitor C1 voltage ( $V_m$ ) and the input voltage ( $V_m$ ) is added to the capacitor C2 I.e Capacitor voltage + input voltage =  $V_m + V_m = 2V_m$ . As a result, the capacitor C2 charges to  $2V_m$ .

During second positive half cycle:

During the second positive half cycle, the diode D3 is forward biased whereas diodes D1 and D2 are reverse biased. Diode D1 is reverse biased because the voltage at X is negative due to charged voltage  $V_m$ , across C1 and diode D2 is reverse biased because of its orientation. As a result, the voltage ( $2V_m$ ) across capacitor C2 is discharged. This charge will flow to the capacitor C3 and charges it to the same voltage  $2V_m$ .

The capacitors C1 and C3 are in series and the output voltage is taken across the two series connected capacitors C1 and C3. The voltage across capacitor C1 is  $V_m$  and capacitor C3 is  $2V_m$ . So the total output voltage is equal to the sum of capacitor C1 voltage and capacitor C3 voltage i.e.  $C1 + C3 = V_m + 2V_m = 3V_m$ .

Therefore, the total output voltage obtained in voltage tripler is  $3V_m$  which is three times more than the applied input voltage.

### Pulse Width Modulation

Pulse width modulation, or PWM, has become an accepted method for generating unique signals, due to the advancement of microcontrollers and its power efficiency. To create a sinusoidal signal, PWM uses high frequency square waves with varying duty cycles. Duty cycle is the percentage of time the signal is on relative to the period. This means as the duty cycle increases, more power is transmitted. PWM requires rapid on and off signals, which can be achieved using high power MOSFETs. MOSFETs are ideal switches due to the low power loss when the device is activated. It should be noted, however, that when a MOSFET is in transition between on and off, the power loss can be significant. For this reason, the transition times and frequency should be engineered to be as short as possible. This can be achieved by minimizing the amplitude between the on and off stages and lowering the PWM frequency; however as the frequency decreases so does the signal quality.

Analog bridge PWM inverter

Digital bridge PWM inverter

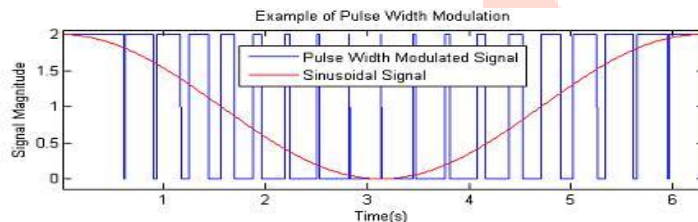

Analog Bridge PWM Inverter

In analog bridge PWM signal is generated by feeding a reference and a carrier signal to a comparator which creates the output signal based on the difference between the two inputs. The reference is a sinusoidal wave at the frequency of the desired output signal. The carrier wave is a triangle or saw tooth wave which operates at frequency significantly greater than the reference wave. When the carrier signal exceeds the reference the output is at high state and when the reference exceeds the carrier the output is at low state.

### Digital Bridge PWM Inverter

Also known as microcontrollerbased power inverter. it makes the controller free from disturbance and drift but the performance is not very high due to its speed limitation. However, to reduce through put delay some microcontroller retrieve switching pattern straight from memory so calculation can be minimized, but this technique demands more memory. This drawback can be eliminated by switching patterns executing simple control algorithms. With availability of advanced microcontroller and DSP (digital signal processor) controller that has advanced features like inbuilt PWM generator, event manager, time capture unit, dead time delay generator, watch dog timer along with high clock frequency, the limitation of speed associated with microcontroller can be neglected to some extent.

As mentioned earlier a DC-AC power inverter is a circuit which modifies an input non-varying direct current (DC) to an alternating current (AC) of a specified voltage and frequency, and a regulated DC voltage. In the

case of this project, the input DC voltage source will be a battery of 24V. As such, the DC voltage will likely be inconsistent, and considerations will need to be made in order to produce the desired output. This desired AC output is a 240Vrms, 50Hz pure sine wave, or what would be seen out of a standard Kenyan wall socket. This will allow the system to output power which is usable by any load. The key concerns regarding the power inverter system are:

### H-Bridge

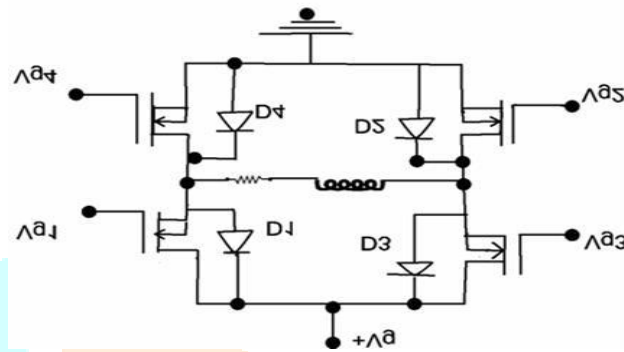

Fig. H-bridge

An H-Bridge or full bridge converter is a switching configuration composed of four switches in this case MOSFETs in an arrangement that resembles an H [10]. By controlling which switches are closed at any given moment, the voltage across the load can be either positive, negative, or zero. As shown in fig 3.7 a solid state h-bridge is built using four switches. When switch S1 and S2 are closed (according to fig 3.7) and switches S3 and S4 are open a positive voltage will be applied across the load. By closing S3 and S4 switches and opening S1 and S2 switches a reverse voltage will be applied to the load. Using nomenclature above switches S1 and S4 should never be closed at the same time as this will cause a short circuit on between the power supply and ground, potentially damaging the devices or draining the power supply. The same applies to switches S2 and S3. This condition is known as shoot-through. The table below outlines the positions.

S1	S2	S3	S4	$V_o$
ON	ON	OFF	OFF	+Ve
OFF	OFF	ON	ON	-Ve
ON	OFF	ON	OFF	ZERO
OFF	ON	OFF	ON	ZERO



## IV RESULTS AND DISCUSSION

A static contactless charging system for EVs. This type of contactless charging is well suited for public transport applications, where it can be used to charge the bus while waiting at the station and also the mass transit applications, where it can be used at parking areas at shopping mall, commercial buildings, etc.



Fig. Result

## V. CONCLUSION

Contactless EV charging systems in static mode offer a convenient and efficient solution for charging electric vehicles in various scenarios. Whether used at public charging stations, for fleet charging, residential applications, or workplace charging, contactless systems streamline the charging process and make it more user-friendly for EV owners. By eliminating the need for physical cable connections, contactless EV charging systems provide a hassle-free experience while promoting sustainability and reducing carbon emissions. Overall, the adoption of contactless EV charging systems in static mode represents a significant step forward in advancing the electrification of transportation and creating a more sustainable future

## VI. REFERENCES

- [1] Siqi Li and Chunting Chris Mi " Wireless Power Transfer For Electric vehicle applications" IEEE journal of Emerging and Selected Topics In Power Electronics, Vol. 3, No.1, March 2015
- [2] A. K. A. Kurs, R. Moffatt, J. D. Joannopoulos, P. Fisher, and M. Soljaic, "Wireless power transfer via strongly coupled magnetic resonances," Science, vol. 317, no. 5834, pp. 83–86, 2007.
- [3] A. P. Sample, D. A. Meyer, and J. R. Smith, "Analysis, experimental results, and range adaptation of magnetically coupled resonators for wireless power transfer," IEEE Trans. Ind. Electron., vol. 58, no. 2, pp. 544–554, Feb. 2011.
- [4] B. L. Cannon, J. F. Hoburg, D. D. Stancil, and S. C. Goldstein, "Magnetic resonant. coupling as a potential means for wireless power transfer to multiple small receivers," IEEE Trans. Power Electron., vol. 24, no. 7, pp. 1819–1825, Jul. 2009.

