



INTERNATIONAL JOURNAL OF CREATIVE RESEARCH THOUGHTS (IJCRT)

An International Open Access, Peer-reviewed, Refereed Journal

Gas Monitoring & Ventilation System In Underground Coal Mine

A Mine ventilation system

Karan Dubey ,
BTech Scholar,

Sakshi urkude ,
BTech Scholar ,

Runali Ninave ,
BTech Scholar,

Hirendra Hajare
Assistant Professor

Computer Science & Engineering
Ballarpur Institute of Technology, Ballarpur , India

Abstract : “Gas Monitoring & Ventilation System In the Underground Coal Mine” presents the design and implementation of a Gas Monitoring & Ventilation System for underground coal mines using an Arduino Nano board, MQ2 gas sensors, flame sensors, and ventilation fans. The system monitors hazardous gases and flames in real-time, triggering ventilation fans to mitigate risks when dangerous levels are detected. The goal is to enhance miner safety, reduce the risk of accidents, and ensure compliance with safety regulations. The paper also discusses the advancements in underground gas testing and reviews significant mine disasters to highlight the system's importance.

This paper presents the development and implementation of a Gas Monitoring & Ventilation System specifically designed for underground coal mines. The system utilizes an Arduino Nano board, MQ2 gas sensors, flame sensors, and ventilation fans to monitor and manage hazardous gases and flames in real-time. When dangerous levels of gases are detected, the system automatically activates ventilation fans to mitigate risks. The primary aim of this project is to enhance miner safety, reduce the risk of accidents, and ensure compliance with stringent safety regulations. Additionally, the paper discusses recent advancements in underground gas testing technologies and reviews significant mine disasters to underscore the necessity of such systems.

Index Terms : Risk Factors , Gas Monitoring , Gas Alerting , Automatic Ventilation System.

I Introduction :

Underground coal mining poses significant risks due to the accumulation of hazardous gases such as methane and carbon monoxide, as well as the potential for fire. Traditional methods of gas monitoring often fall short in providing timely alerts and effective ventilation control. This research focuses on developing a cost-effective, automated system to monitor and manage gas levels, ensuring a safer working environment for miners.

Underground coal mining is fraught with dangers, particularly due to the accumulation of hazardous gases such as methane and carbon monoxide, as well as the potential for fires. Traditional gas monitoring methods often fail to provide timely alerts and effective ventilation control, leading to catastrophic consequences. This research focuses on developing a cost-effective, automated system that continuously monitors gas levels and manages ventilation, thereby ensuring a safer working environment for miners. By leveraging modern sensor technology and automation, this system aims to significantly improve safety standards in underground coal mines.

The Gas Monitoring & Automatic Ventilation System Project aims to address this critical need by designing & developing an advanced System capable of Continuously monitoring gas concentrations in the mine Atmosphere & Automatically regulating the mine's ventilation system to maintain safe working Conditions for Miner.

Coal mines are perilous environments due to the presence of combustible gases like methane and toxic gases such as carbon dioxide. Methane is particularly dangerous because it is both highly flammable and capable of forming explosive mixtures with air. Traditional gas detection methods, such as flame safety lamps and canaries, have been largely superseded by more advanced electronic monitoring systems. This paper aims to present a modern approach to gas monitoring and ventilation using an Arduino-based system, offering a significant improvement in terms of real-time detection and automated response to hazardous conditions.

1.1 AIMS AND OBJECTIVES :

The aim of this project is to design and develop a Gas Monitoring and Automatic Ventilation System for underground coal mines. The system will be capable of continuously monitoring gas concentrations in the mine atmosphere and automatically regulating the mine's ventilation system to maintain safe working conditions for miners.

1. **Gas Detection:** Develop a system for the continuous monitoring of gas concentrations in the mine atmosphere, including methane, carbon monoxide, and hydrogen sulfide.
2. **Sensor Integration:** Integrate advanced gas sensors throughout the mine to provide comprehensive coverage and accurate gas concentration readings.
3. **Data Acquisition and Processing:** Design and implement algorithms for real-time data acquisition, processing, and analysis of gas concentration readings.
4. **Alarm System:** Develop an alarm system to alert miners when gas concentrations reach dangerous levels and prompt them to evacuate the area.
5. **Automatic Ventilation Control:** Integrate the gas monitoring system with the mine's ventilation system to automatically adjust airflow based on gas concentration levels.
6. **Testing and Validation:** Conduct rigorous testing of the system in simulated and real-world mine environments to ensure reliability and effectiveness.
7. **Safety and Compliance:** Ensure that the system complies with safety standards and regulatory requirements for gas monitoring and ventilation in underground coal mines.

II RELATED WORK :

The Gas Monitoring & Ventilation System project aims to design and develop an advanced system for continuous gas monitoring and automatic ventilation control in underground coal mines. Design and integration of advanced gas sensors capable of detecting methane (CH₄), carbon monoxide (CO), and hydrogen sulfide (H₂S) in the mine atmosphere. Selection and optimization of sensor placement to ensure comprehensive coverage and accurate gas concentration readings throughout the mine. Development of algorithms for real-time data acquisition, processing, and analysis of gas concentration readings. Implementation of data logging and storage capabilities to maintain a record of gas concentration data for analysis and reporting. Design and implementation of an alarm system to alert miners when gas concentrations reach dangerous levels. Integration of visual and auditory alarms to provide prompt and effective warnings to miners in the event of a gas-related emergency. Integration of the gas monitoring system with the mine's ventilation system to automatically adjust airflow based on gas concentration levels. Development of feedback control algorithms to regulate ventilation rates and ensure safe working conditions for miners. Continuous testing of the system in simulated and real-world mine environments to evaluate its performance and reliability. Validation of system functionality against safety standards and regulatory requirements for gas monitoring and ventilation in underground coal mines.

III RESEARCH METHODOLOGY :

1. **System Design :** The system centers around the Arduino Nano microcontroller, chosen for its compact size and versatility. The MQ-4 methane sensors are utilized for detecting methane concentrations, and flame sensors are included for detecting fires. The Arduino Nano processes data from these sensors and controls the ventilation fans based on the sensor readings. The initial phase of the research methodology focuses on the overall design of the system. The Arduino Nano was selected as the core microcontroller due to its compact size, versatility, and ease of programming. The small form factor of the Arduino Nano allows it to be easily integrated into the confined and rugged environments typical of underground coal mines. The system is designed to interface with multiple sensors and control output devices, ensuring comprehensive monitoring and automated responses. The design process involved creating detailed schematics and circuit diagrams to map out the connections between the Arduino Nano, sensors, ventilation fans, and alarms. The design also included considerations for power supply, ensuring that the system could operate reliably under varying conditions within the mine.
2. **Data Collection Method :** Data collection is a critical component of this research, focused on gathering accurate and relevant information from the sensors deployed in the underground coal mine. The primary data sources are the MQ-4 methane sensors and flame sensors connected to the Arduino Nano. These sensors continuously monitor the environment for methane gas concentrations and the presence of flames, respectively. The Arduino Nano collects real-time data from these sensors, which is then processed and logged for further analysis. Additionally, environmental data such as temperature and humidity can be collected using supplementary sensors to provide a comprehensive understanding of the mine's conditions. This continuous data collection ensures that any changes in the gas levels or potential fire hazards are promptly detected and addressed.

In-Dept Conversation and Interviews will be Conducted with the Mine Safety Experts , mine operators & Miners to Explore their perspectives on the Gas Monitoring & Ventilation System in the Underground coal Mine.

3. **Sampling Techniques :**

In this research, a systematic sampling technique is employed to ensure that data is collected uniformly across different sections of the mine. Sensors are strategically placed in key locations, such as near workstations, along ventilation pathways, and in areas with high methane potential. This placement ensures that the samples are representative of the entire mining environment. By systematically covering different zones, the system can detect local gas accumulations and identify areas that may require additional ventilation or other safety measures. The sampling frequency is set to collect data at regular intervals, ensuring timely detection of hazardous conditions. This approach helps in creating a detailed and accurate map of gas concentrations throughout the mine. In the context of developing and implementing a "Gas Monitoring & Ventilation System in the Underground Coal Mine," effective sampling techniques are critical to ensure comprehensive and accurate detection of hazardous gases. The sampling strategy involves both the spatial distribution of sensors within the mine and the temporal frequency at which data is collected. This systematic approach is designed to capture a representative snapshot of the mine's atmospheric conditions, ensuring that any dangerous gas accumulations are promptly identified and mitigated.

4. **Data Analysis :**

Data analysis involves processing the raw data collected from the sensors to extract meaningful insights and actionable information. The Arduino Nano processes sensor data in real-time, comparing the readings against predefined safety thresholds. When methane concentrations exceed safe levels or flames are detected, the system triggers an immediate response, such as activating ventilation fans or sounding alarms. Additionally, the collected data is stored for further analysis, which involves statistical methods to identify patterns, trends, and anomalies in gas concentrations.

Advanced data analysis techniques, such as time-series analysis and spatial analysis, are used to predict potential hazardous conditions and optimize the placement of sensors and ventilation systems. This comprehensive analysis helps in refining the system's performance and ensuring its effectiveness in maintaining mine safety.

5. **Validity & Reliability :**

Ensuring the validity and reliability of the gas monitoring and ventilation system is paramount. Validity refers to the accuracy and truthfulness of the system's measurements, while reliability pertains to the consistency and dependability of the system over time. To ensure validity, the sensors are calibrated using known gas concentrations and controlled flame sources. This calibration process verifies that the sensors provide accurate readings under different conditions. The system's algorithms are also tested extensively to ensure they correctly interpret sensor data and trigger appropriate responses. To ensure reliability, the system undergoes rigorous testing in various operational scenarios, including different environmental conditions and gas concentration levels. Redundancies are built into the system, such as multiple sensors and backup power supplies, to ensure continuous operation even in adverse conditions. Regular maintenance and recalibration of sensors are also part of the reliability strategy, ensuring that the system remains functional and accurate over extended periods.

<p>By incorporating thorough data collection methods, systematic sampling techniques, detailed data analysis, and stringent measures to ensure validity and reliability, this research methodology provides a robust framework for developing and deploying an effective gas monitoring and ventilation system in underground coal mines. These methodological components work together to create a system that not only detects hazardous gases promptly but also provides reliable and actionable data to enhance overall mine safety.</p>	<p>Name</p>	<p>Primary sources in mines</p>	<p>Hazards</p>	<p>Flammability limits in air</p>
--	-------------	---------------------------------	----------------	-----------------------------------

			(%)
Methane(CH ₄)	Strata	Explosive, Breathing problem	5 to 15
Carbon dioxide (CO ₂)	Oxidation of carbon, fires, explosions	Increased heart rate and breathing	N/A
Carbon monoxide(CO)	Fires, Explosions, blasting, incomplete combustion of carbon compounds	Highly toxic, Explosive	12.5 to 74.2
Sulphur dioxide (SO ₂)	Oxidation of Sulphides, acid water on sulphide ores	Toxic, irritant to eyes, Throat and lungs	N/A
Nitrogen dioxide (NO ₂)	IC engines, blasting, fumes, welding	Toxic, Throat and lung infections	N/A
Hydrogen Sulphide (H ₂ S)	Acid water on sulphides, Strata decomposition of organic materials	Highly Toxic, irritant to eyes and explosive	4.3 to 45.5

TABLE-1 : The above table Showing the Gases , Their primary Sources in the mines , Hazards & the Flammability limits in the Air

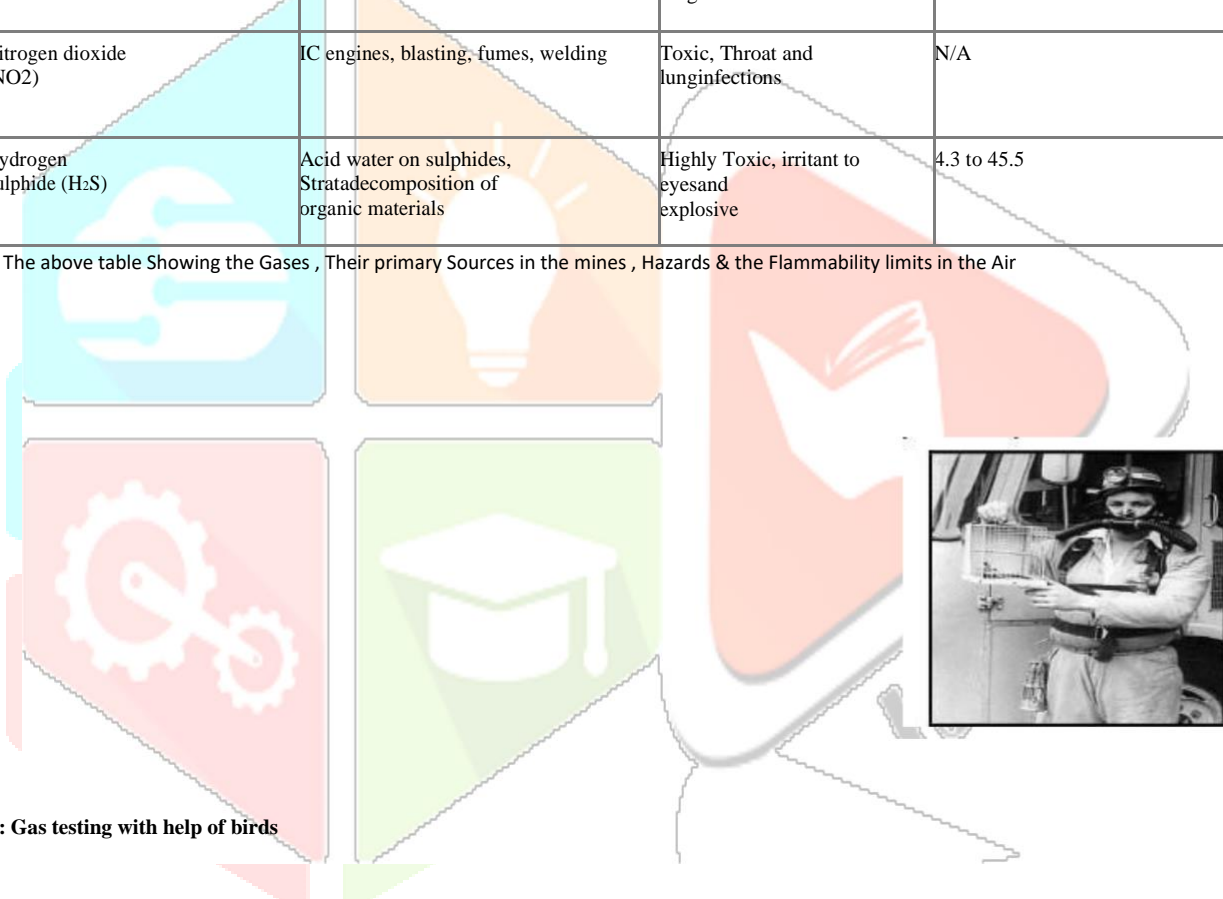

Figure 1 : Gas testing with help of birds

IV ADVANCEMENTS IN UNDERGROUND GAS TESTING

A. Gas Testing by Warm Blooded Bird :

Miners would take caged canaries with them into the mines. These birds have a higher metabolic rate and faster breathing patterns, making them more susceptible to the effects of toxic gases than humans. If a canary showed signs of distress, such as erratic behavior or lethargy, or if it died, it indicated the presence of dangerous gas levels. This early warning allowed miners to evacuate the area before the gas concentrations became harmful to humans. The use of canaries was straightforward and did not require complex equipment, which made it an accessible method for detecting gas. However, this approach had several limitations. It did not provide precise information about the type or concentration of the gas, and it relied on continuous visual monitoring of the birds by the miners. Furthermore, ethical concerns arose from using live animals for safety purposes.

B. Flame Safety Lamp :

The flame safety lamp operates on a simple yet effective principle. It consists of a small oil flame enclosed within a mesh screen or a perforated metal shield. This design allows the flame to burn while preventing it from igniting any flammable gases outside the lamp. When methane or other flammable gases are present, they alter the appearance of the flame. For instance, methane causes the flame to elongate or change color, serving as a visual indicator of gas concentration. Miners could use this information to assess the safety of their environment and take necessary precautions.

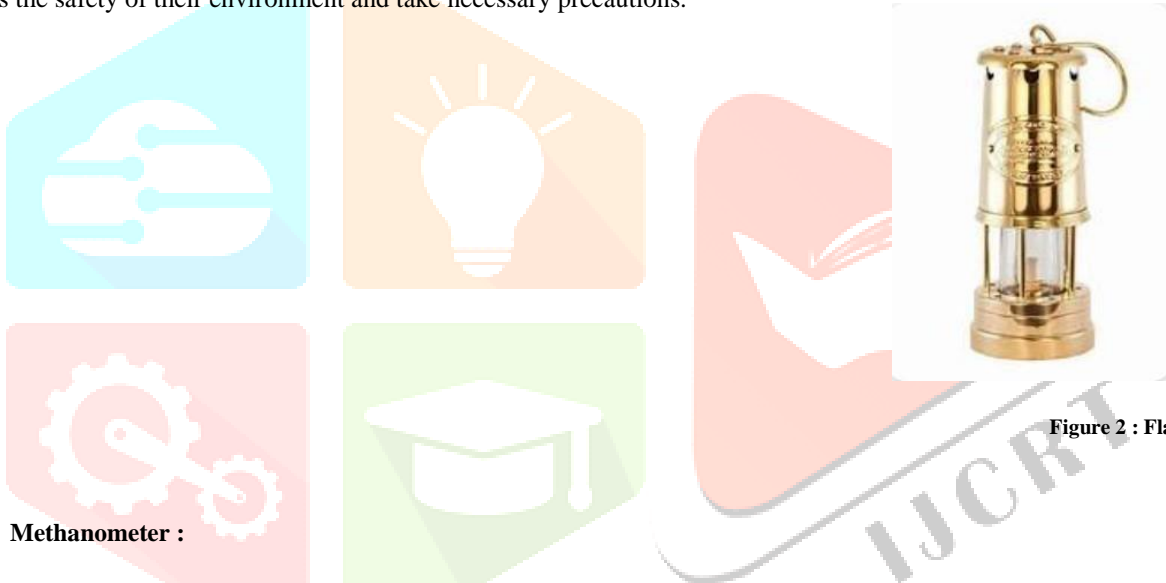

Figure 2 : Flame Safety lamp

C. Methanometer :

Automatic fire damp detectors are sophisticated devices equipped with sensitive electronic sensors that can detect the presence of methane gas in the mine atmosphere. These detectors typically use semiconductor, catalytic bead, or infrared sensors to measure the concentration of methane. When the gas concentration reaches a predefined threshold, the detector triggers an alarm system to alert miners of the danger. This automated response system ensures immediate action can be taken to mitigate the risk, such as increasing ventilation or evacuating the area.

One of the key advantages of automatic fire damp detectors is their ability to provide continuous monitoring without the need for human intervention. This constant vigilance significantly reduces the risk of undetected gas accumulations, which can lead to explosions. Furthermore, these detectors often come with data logging capabilities, allowing for the analysis of gas concentration trends over time. This data can be invaluable for improving mine safety protocols and preventive maintenance strategies.



Figure 3 Methanometer

V, MINE ACCIDENTS & DISASTERS DUE TO THE DANGEROUS GAS PRESENTS IN THE MINE :

S . no.	Date	Places of Accident	Cause of Accident	Fatalities
1.	Sep. 06,2006	Nagada Incline of Bhatdihcolliery , BCCL, India .	Explosion in the mines due to the Accumulation of Methane .	50 miners were declared dead.
2.	Feb .22.2009	Tunlan, Underground Coal mine, Northern China	Poor Ventilation was Responsible for the Accumulation of The methane Gas .	77 miners were Dead and 114 were hospitalized
3.	Oct . 28. 2013	Underground Coal Mine , North Western Area , Spain.	Accumulation of the Methane Gas.	6 miners have been recorded Dead.

TABLE-2 : The above table showing Date , Places of Accident , Cause of Accident & Fatalities

I. COMPONENTS USED IN THE SYSTEM :

1. Arduino Nano :

The Arduino Nano plays a central role in managing the entire system's operations. As the brain of the system, the Arduino Nano is responsible for interfacing with various sensors, processing their data, and controlling the ventilation fans to ensure a safe environment within the mine. The Arduino Nano collects real-time data from the MQ-2 gas sensors and flame sensors deployed throughout the mine. The MQ-2 sensors detect the presence and concentration of various hazardous gases, such as methane (CH4) and carbon monoxide (CO), while the flame sensors identify the presence of flames, indicating potential fires.

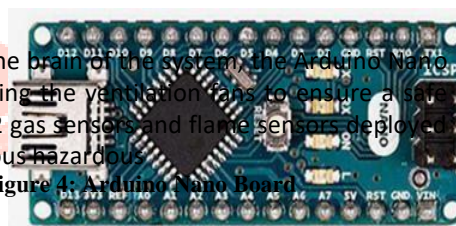

Figure 4: Arduino Nano Board

2. **MQ-4 Methane Sensors :**

The MQ-4 Methane Sensor is a crucial component in the "Gas Monitoring & Ventilation System in the Underground Coal Mine" project. This sensor is specifically designed to detect methane (CH₄) gas, a common and dangerous presence in coal mines. The MQ-4 sensor is known for its high sensitivity, fast response time, and robustness, making it ideal for ensuring the safety of miners by continuously monitoring methane levels.

The MQ-4 Methane Sensor is a vital element in the "Gas Monitoring & Ventilation System in the Underground Coal Mine," contributing significantly to the overall effectiveness of the safety measures in place



Figure 5 : MQ-4 Methane Sensors

3. **Flame Sensors :**

Flame sensors are electronic devices designed to detect the presence of flames or fires. These sensors are commonly used in various applications, including fire detection systems, gas appliances, industrial processes, and safety equipment. flame sensors are essential safety devices used to detect the presence of flames or fires in a wide range of applications, providing early detection and ensuring the safety of personnel and property.



Figure 6 : Flame Sensors

4. **16x2 I2C LCD Display: Displays real-time sensor readings and alert messages.**



Figure 7 : 16*2 LCD Display

5. **TP4056 Li-ion Battery Charging Module,**

6. **Buzzer**

7. **LED**

8. **Digital I/O Pins: Used for triggering alarms.**

9. **Transistor BC847: Used for triggering alarms, LED and Relay.**



Figure 8 : Buzzers

10. **Zero PCB, Resistors, and Connecting Wires: For circuit assembly**

VI. SYSTEM ARCHITECTURE :

The system architecture for the "Gas Monitoring & Ventilation System in the Underground Coal Mine" is designed to ensure comprehensive monitoring and rapid response to hazardous gas levels. At the core of the system is the Arduino Nano, which acts as the central processing unit. It collects data from multiple MQ-4 methane sensors and flame sensors distributed throughout the mine. These sensors continuously detect the presence and concentration of methane and identify potential fire hazards.

The sensor data is transmitted to the Arduino Nano through its analog input pins. The Arduino Nano processes this data in real-time, comparing the detected gas levels against predefined safety thresholds. If methane concentrations exceed safe limits or if a flame is detected, the Arduino Nano triggers the ventilation fans. These fans work to disperse the hazardous gases, reducing their concentration to safe levels.

Additionally, the Arduino Nano can activate alarm systems and send alerts to a central monitoring station or directly to miners' devices, ensuring immediate awareness and response to potential dangers. This integrated approach ensures that the system provides continuous monitoring, quick detection, and timely intervention, maintaining a safe working environment in the underground mine.

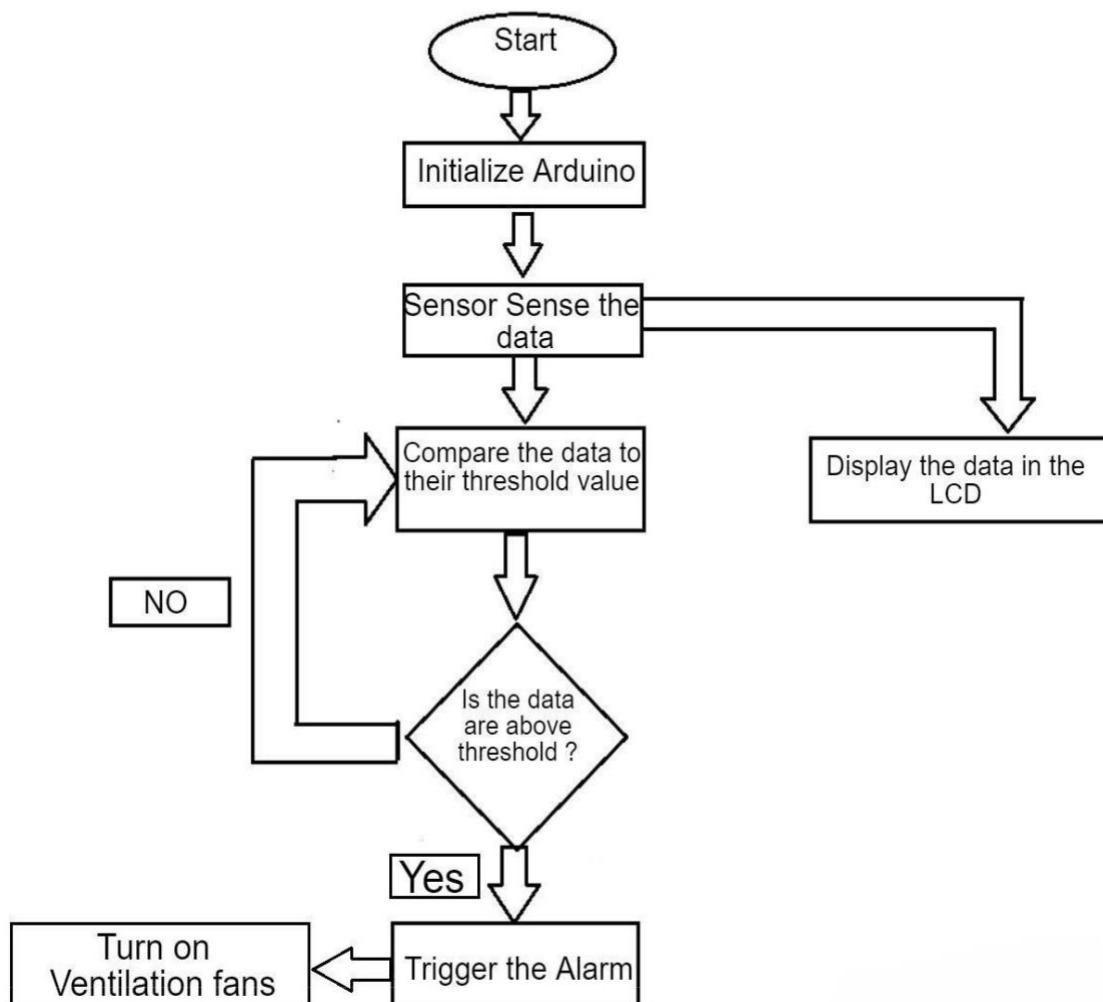

Figure 9 : The Flow Chart of the System Architecture of the Sensor Unit.

→ **BLOCK DIAGRAM OF SENSOR SYSTEM :**

Fig. 10 : Showing the Block Diagram of the system.

VII. Installation Areas in the underground Mines / Workspaces :

The installation zones for the gas monitoring and ventilation system in an underground coal mine are strategically selected to maximize safety and efficiency. These zones are chosen based on areas with the highest risk of gas accumulation and potential hazards.

1. Mine Entrances & Exits
2. Workfaces and Active Mining Areas
3. Ventilation Shafts and Airflow Routes
4. Abandoned and Less- Visited Areas
5. Goaf Area In the Underground Mine
6. Underground Storage Areas and Equipments Areas
7. Galleries of the Mines
8. Junctions in the Mine
9. Various Faces in the Mine

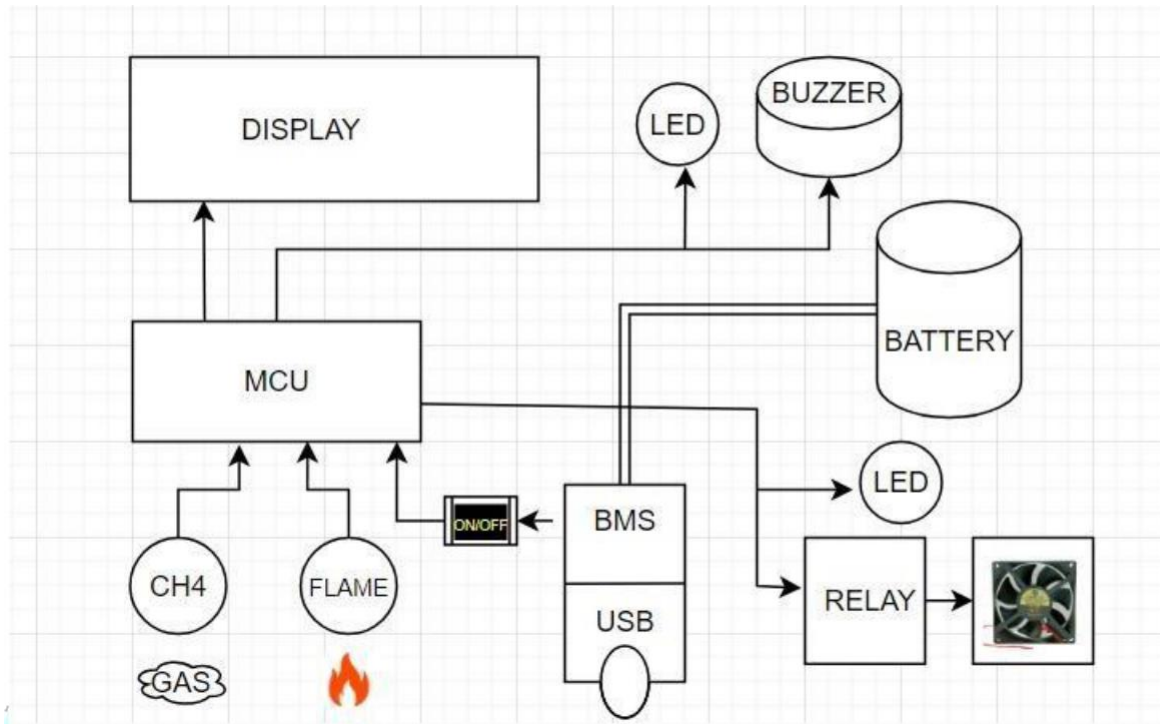
By strategically placing the sensors in these critical zones, the system ensures comprehensive coverage of the entire mining environment. This strategic placement helps in early detection and quick response to hazardous conditions, thereby maintaining the safety and health of miners.

VIII CONCLUSION :

“Gas Monitoring And Ventiltion System in the Underground Coal Mine ” effectively uses simple electronic components to create a responsive and potentially lifesaving system based on environmental sensor readings.

This project successfully demonstrates the integration of an Arduino-based system with environmental sensors to detect hazardous conditions related to methane concentrations and fire presence. The use of the MQ-4 methane sensor and a flame sensor provides real-time monitoring of potentially dangerous situations, enabling automated responses to mitigate risks .

The integration of these components creates a robust, automated response system that enhances safety protocols beyond traditional methods. The real-time data processing and immediate response capabilities of the Arduino Nano, combined with the high sensitivity of the MQ-4 sensors, ensure that any rise in methane levels or detection of flames is promptly addressed. This automated intervention is crucial in preventing accidents and minimizing the risk of explosions and fires within the mine.

IX ACKNOWLEDGMENT

We wish to express our profound appreciation to Hirendra Hajare, our esteemed project guide, whose expert guidance, unwavering support, and insightful feedback have been indispensable throughout the entirety of this research endeavor. Their dedication to fostering our intellectual growth and research acumen has been instrumental in shaping the direction and rigor of our study. Additionally, we extend our gratitude to the diligent members of our research team, whose collaborative efforts and tireless commitment have greatly enriched the project's outcomes. Their diverse perspectives, skills, and contributions have enhanced the depth and breadth of our research, fostering a collaborative environment conducive to innovation and excellence.

Furthermore, we would Really like to Serve our sincere thanks to the Team Members who generously volunteered their time and expertise, contributing invaluable insights and perspectives to our study. Their willingness to share their experiences and knowledge has enriched our understanding of the subject matter and has greatly enriched the quality of our research outcomes. We acknowledge the support of Ballarpur Institute of Technology for providing the necessary resources, facilities, and infrastructure that facilitated the successful completion of this research project. Their commitment to fostering a conducive research environment has been essential in our academic journey.

Last but not least, we express our deepest gratitude to our families and friends for their unwavering support, encouragement, and understanding throughout the duration of this research endeavor. Their patience, love, and belief in our abilities have been a constant source of strength and motivation, fueling our determination to overcome challenges and achieve our research goals.

REFERENCES:

- Deshmukh.D.J. (2014). Elements of Mining Technology vol 2. Nagpur: ennet.
- <http://www.buzzle.com/articles/methane-gas-exposure-symptoms.html>
- Srivastava.S.K, real time monitoring system using wireless sensornetwork (2015).
- Deshmukh.D.J. (2014). Elements of Mining Technology vol 1. Nagpur:ennet.
- <http://www.arduino.cc/>
- Boddu, R., Balanagu, P., Babu, N.S. (2012), “Zigbee based mine safety monitoring system with GSM”
- <https://www.sparkfun.com/datasheets/Sensors/Biometric/MQ-7.pdf>
- <https://www.sparkfun.com/datasheets/Sensors/Biometric/MQ-4.pdf>
- Misra.G.B, (1986), Mine Environment and Ventilation. New Delhi:Oxford University Press.
- Directorate General of Mines Safety (DGMS). (2017 Coal Mines Regulations, 2017. Retrieved from <http://dgms.gov.in/>
- Central Mine planning and Design Institute Limited (CMPDI). (Year). Manual on Mine Ventilation and Cooling Systems , retrieved from <http://cmpdi.co.in/>
- Coal India limited (CIL), Standard operating Procedures (SOPs) for Gas Monitoring and Ventilation in the Underground Coal mines , Retrived from <http://coalindia.in/>
- Indian Institute of Technology(IIT) Dhanbad, Research Papers and Studies on Gas Monitoring , Ventilation , and Safety in the underground coal Mines . Retrived From <http://iitism.ac.in/>

- Indian Bureau of Mines (IBM) , Guidelines for the Mine Ventilation and safety in the Underground coal mines . retrived from <http://ibm.gov.in/>
- National institute of Occupational Health (NIOH) , research Reports and Publications on the Occupational Health Hazards in the coal mines, Retrived from the <http://nioh.org/>
- Buczek , p ,Felsman,C, & Orska , A.(2000). Analysis of Gas monitoring System for the coal mines . IOP Conference Series : Earth and Environment Science , 496(1) , 012020.
- Sharma , A , & Yadav , R ,(2020). Development of an Embedded System for the Real-time Monitoring of the Gas Concentrations in the Underground Coal Mines. International Journal of the Computer Applications , 173(9), 1-5.
- Society of geoscientists and Allied Technology (SGAT), Conference and Workshop on the mine Safety and Tecnology , retrived from <http://ijcg.com/>
- International Journal of the Coal Geology (IJCG), Research Article on the Coal Geology and Mining Technology , retrived from <http://ijcg.com/>
- Ventilation and Occupaional Environment Engineering book by Prof. J.J,L. Du plesis.
- Indian minerals & Metals Corporation (IMMC) , Reports and Publications on the Mine Safety and Technology , Retrived from the – <http://immc.org/>
- Gas Monitoring & alerting system in the Underground Mine received from [https:// IJCRT.com/](https://IJCRT.com/)

