

SEAT BELT IMPLEMENTATION USING CAPL SCRIPTING

1st Dr.N.Karthik
Assoc.Professor

Dept. of EEE
Bapatla Engineering College
Bapatla,India

2ndMr.S.Rambabu

Dept.of EEE
BapatlaEngineeringCollege
Bapatla,India

3rd Mr.G.Vinay Kumar

Dept.of EEE
BapatlaEngineeringCollege
Bapatla,India

4th Mr.G.Vignesh

Dept.of EEE
BapatlaEngineeringCollege
Bapatla,India

Abstract— This approach not only increases time to market, but also ensures that the asset is reliable and meets safety and quality standards. Additionally, SIL simulation facilitates collaboration between different teams, accelerates process improvement, and encourages innovation in vehicle design. Rapid advances in technology require advanced techniques for designing and implementing complex systems such as measuring devices. Software-in-the-loop (SIL) simulation has become an important technology to improve the efficiency and accuracy of the development process. network integration

Keywords—Seat belt monitoring, CAPL scripting, Automotive safety, Electronic control units, Communication protocols.

1.INTRODUCTION

In the realm of automotive safety, seat belt usage stands as a fundamental pillar for protecting occupants in the event of a crash. As vehicles become increasingly sophisticated, integrating advanced technologies to enhance safety features has become paramount. One such technology is the implementation of seat belt monitoring systems, which ensure that occupants are properly restrained during travel. This introduction sets the stage for understanding the significance of seat belt implementation using CAPL (Communication Access Programming Language) scripting. CAPL scripting serves as a powerful tool within the automotive industry, allowing for the development of test and diagnostic applications that interface directly with a vehicle's electronic control unit (ECU) and sensor inputs. The implementation of seat belt monitoring systems using CAPL scripting involves a multifaceted approach that encompasses hardware, software, and rigorous testing procedures. By leveraging CAPL's capabilities for real-time data processing and control, automotive manufacturers can develop sophisticated seat belt monitoring systems that not only enhance safety but also comply with regulatory standards

1.1 CAPL Scripting

CAPL (Communication Access Programming Language) scripting is a specialized programming language extensively used in the automotive industry for developing test and diagnostic applications. CAPL scripting serves as a powerful

tool for interacting with electronic control units (ECUs) and communication buses within vehicles, facilitating simulation, testing, and diagnosis of vehicle functionalities

TS MASTER TOOL

- Searching online for the official website or documentation of the software.
- Contacting the manufacturer or developer of the software for information.
- Checking with colleagues or peers who may have experience using the software.



Fig 1.1 Seat belt indicator

2. System Architecture of Seat Belt Implementation

The system architecture for seat belt implementation integrates sensor inputs, signal processing, CAPL scripting, and alerting mechanisms to ensure comprehensive monitoring and enforcement of seat belt usage. Beginning with sensor inputs from seat belt buckle and tension sensors, data is processed by a signal processing unit and accessed in real-time through CAPL scripts. Decision logic within the CAPL scripts interprets sensor data to determine seat belt status, triggering appropriate alerts such as visual dashboard indicators or audible alarms to remind occupants to fasten their seat belts when necessary. This integrated approach promotes occupant safety by encouraging proper seat belt usage and adherence to safety regulations within vehicles.

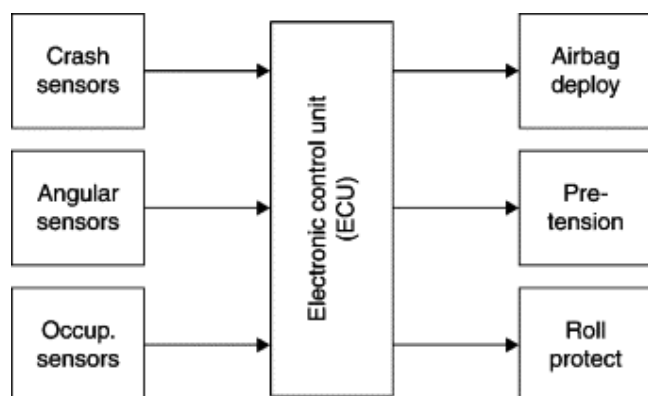

Fig 2.1 Architecture of Seat Belt Implementation

The system starts with sensor inputs, which typically include seat belt buckle sensors and tension sensors. These sensors check whether the seat belt is fastened (buckled) or loose (unbuckled) and measure the tension of the seat belt. The sensor data is sent to the operating signal, which can be integrated into the vehicle's electronic control unit (ECU) or used as a separate module. This unit processes sensor data and converts it into a digital signal for further analysis. The CAPL script takes care of signal processing to provide real-time access to digital sensor data. The CAPL script was created to interpret sensor data and monitor belt conditions, including alignment and tension levels. In the CAPL letter, use your judgment to determine the appropriate course of action to monitor seat usage. This theory may include criteria for determining when to wear a seat belt, such as a speeding vehicle or driver/passenger. As a result of the decision, the alarm was activated to warn the passengers about the condition of the seat belt in the vehicle. These mechanisms may include visual alerts (such as dashboard icons or warning lights) and audible alerts (such as chimes or sounds). Seat belt police together with other vehicles ensure the work is perfect and harmonious. The seat belt connects with the rest of the vehicle to ensure perfect operation and compatibility. This integration will interact with existing safety systems, such as airbag deployment systems to improve the overall safety of the vehicle. The system has undergone extensive testing and validation to ensure reliability and performance in various applications. This includes simulated scenarios, real-world testing, and compliance testing with safety standards and regulations. The seat belt connects with the rest of the vehicle to ensure perfect operation and compatibility. This integration will interact with existing safety systems, such as airbag deployment systems, to improve the overall safety of the vehicle.

3. CAPL Scripting Methodologies

The CAPL scripting approach includes methods for creating scripts for traffic applications. Starting with a good requirements analysis, developers present the project's goals, inputs, outputs, and constraints. Design based on design principles to create functions, models, and data structures to facilitate interaction with the tool. The messaging system is then used to manage data input and output of the communication system, such as the CAN bus, while the dynamic data processing process transforms the raw data data into understanding. The situation management system delivers the script from different functions and the function is routed allowing immediate response to the right conditions. Error management ensures integrity by identifying and resolving errors, while integration with external tools improves performance. The testing and implementation process effectively checks the written work and complements

the documentation and maintenance plan to ensure long-term reliability and adaptability to needs.

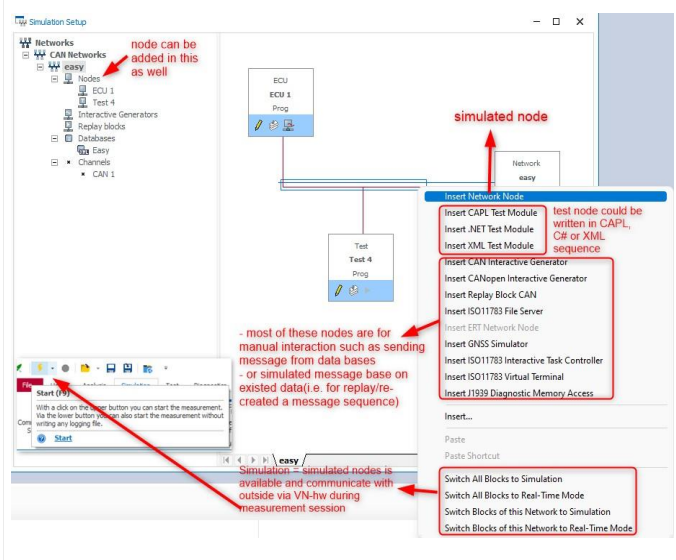

4. Seat Belt Status Monitoring

Seat belt status monitoring is a critical aspect of vehicle safety systems, ensuring that occupants are properly restrained while the vehicle is in motion. This process involves continuously monitoring the status of seat belts, including whether they are buckled or unbuckled, and the tension levels of the seat belt straps.

- **Sensor Types:** Various types of sensors can be used to monitor seat belt status, including pressure sensors, buckle sensors, and weight sensors. These sensors detect whether a seat belt is buckled and if there is weight on the seat.
- **Seat Occupancy Detection:** Seat belt monitoring systems often incorporate seat occupancy detection to determine if a seat is occupied and if the occupant is wearing a seat belt.
- **Indicator Lights:** Many vehicles have indicator lights on the dashboard or center console to alert the driver if any occupants are not wearing their seat belts. These lights typically illuminate when a seat belt is unbuckled.
- **Audible Alerts:** In addition to visual indicators, some vehicles may also emit audible alerts, such as chimes or beeps, to remind occupants to fasten their seat belts.
- **Safety Systems Integration:** Seat belt status information is often integrated with other vehicle safety systems, such as airbag deployment algorithms. This integration can help optimize the vehicle's response in the event of a crash.
- **Seat Belt Reminder Systems:** Modern vehicles are equipped with seat belt reminder systems that provide persistent alerts until all occupants have buckled their seat belts. These reminders can be visual, audible, or both.
- **Occupant Classification Systems (OCS):** OCS can detect the weight and position of occupants in a vehicle and adjust safety systems accordingly. This technology often works in conjunction with seat belt monitoring to ensure that all occupants are properly restrained.
- **Data Logging:** Some vehicles are equipped with data logging capabilities that record seat belt usage over time. This data can be useful for fleet management, compliance reporting, and safety analysis.

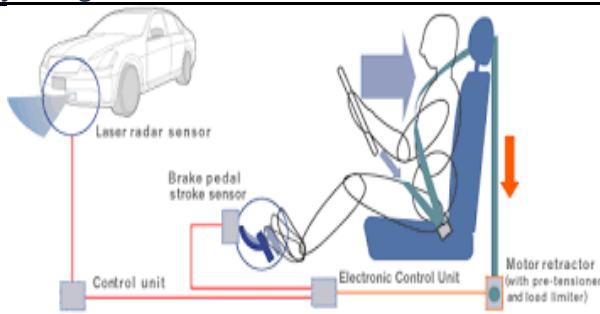

5. Integration and Testing

5.1 Integration

- **System Architecture Integration:** Integrate the seat belt monitoring system components, including sensors, control units, and indicator lights, into the vehicle's overall electrical architecture.
- **Hardware Integration:** Physically install seat belt sensors in each seating position and connect them to the control unit. Ensure proper wiring and connections are made according to the vehicle's electrical system specifications.
- **Software Integration:** Incorporate seat belt monitoring logic into the vehicle's software framework. Integrate CAPL scripts or other software modules responsible for processing sensor data and controlling indicator lights or alert systems.
- **Interface Integration:** Interface the seat belt monitoring system with the vehicle's communication network (e.g., CAN bus). Ensure bidirectional communication between the seat belt control unit and other relevant ECUs.
- **Testing Environment Setup:** Prepare a testing environment that mimics real-world driving conditions, including simulating seat occupancy, seat belt buckling, and unbuckling scenarios.

5.2 Testing

- **Safety Testing:** Assess the system's compliance with safety regulations and standards related to seat belt monitoring. Evaluate whether the system operates safely and reliably under normal driving conditions and during emergency situations.
- **Interface Testing:** Test communication between the seat belt and other ECUs in the vehicle network.

- **User Interface Testing:** Evaluate the effectiveness of indicator lights, audible alerts, or other user interfaces in communicating seat belt status to occupants. Ensure that user interface elements are intuitive and easy to understand. Validate that alert systems provide timely and clear feedback to encourage seat belt usage.

6. CAPL Scripting for Seat Belt Monitoring

CAPL is a powerful scripting language specifically designed for developing communication protocols and performing diagnostic tasks in automotive ECUs. In the context of seat belt monitoring, CAPL scripts are used to interact with the CAN or LIN bus to receive seat belt status messages from the sensors. Upon receiving the status information, the scripts analyze the data to determine the seat belt status for each occupant position in the vehicle. Depending on the detected status (buckled or unbuckled), the scripts trigger corresponding actions, such as activating seat belt reminder indicators, generating audible alerts, or interfacing with other vehicle systems.

- **CAPL Script Initialization:** Begin by initializing the CAPL script within the development environment, ensuring it's appropriately linked to the vehicle's CAN or LIN communication network.
- **Receive Seat Belt Status Messages:** Implement message reception handlers to capture seat belt status messages broadcasted on the vehicle network. These messages typically originate from seat belt sensors distributed throughout the vehicle.
- **Data Parsing:** Extract relevant information from received messages, such as seat occupancy status and seat belt buckling status for each seating position. Parse the received data to determine which seat belts are buckled or unbuckled.
- **Seat Belt Status Logic:** Develop logic within the CAPL script to interpret the parsed seat belt status data and determine the overall seat belt compliance for the vehicle occupants. Consider factors such as seat occupancy, seat belt buckle status, and any regulatory requirements.
- **Alert Generation:** Based on the seat belt status determined by the script logic, trigger appropriate alerts or notifications to the driver and occupants. This may include activating dashboard indicator lights, generating audible warnings, or interfacing with other vehicle systems to enforce seat belt usage.
- **User Interaction Handling:** Implement mechanisms to handle user interactions with the seat belt monitoring system, such as acknowledging alerts or overriding reminders in certain situations (e.g., during low-speed maneuvering or when loading cargo).

7.CAN Data Base

Store historical data regarding seat belt usage in a database. This data can include timestamps, seat occupancy status, seat belt buckle status, and any relevant vehicle information. By logging this information, you can track trends over time, identify patterns of non-compliance, and generate reports for analysis. Allow users to customize seat belt reminder settings, such as the frequency or intensity of reminders, through a user interface. Store these preferences in a database to ensure they persist across vehicle sessions. This allows occupants to tailor the seat belt monitoring system to their preferences for a more personalized experience. Store diagnostic information related to the seat belt monitoring system in a database. This can include error codes, system status, and troubleshooting logs. By centralizing diagnostic data, you can facilitate maintenance and troubleshooting activities, enabling technicians to quickly identify and address issues with the system. Integrate the database with other vehicle systems, such as the onboard diagnostics (OBD) system or the vehicle's telematics unit. This allows for seamless exchange of data between different vehicle components and enables advanced features such as remote diagnostics or predictive maintenance based on seat belt usage patterns. Implement security measures to protect sensitive data stored in the database, such as encryption, access controls, and audit logs. Ensure that only authorized users or systems have access to the data to maintain privacy and compliance with data Utilize the database for real-time data processing and analysis to support dynamic decision-making within the seat belt monitoring system. For example, you can use stored data to adjust reminder settings based on individual driving behavior or to trigger alerts for immediate action in case of non-compliance. Design the database architecture with scalability and performance in mind to accommodate the potential growth of data volume and system usage over time. Consider factors such as data indexing, partitioning, and caching to optimize database performance

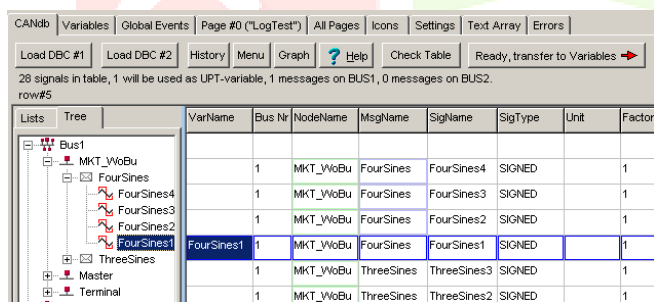

VECTOR CANdb++ is a sophisticated software tool developed by Vector Informatik, tailored specifically for the creation, editing, and management of Controller Area Network (CAN) databases (CANdb). Widely utilized in industries like automotive engineering, where CAN communication protocols are prevalent, CANdb++ provides an intuitive interface for defining messages, signals, and their properties within the CAN network. Its capabilities extend to signal multiplexing, allowing for efficient bandwidth utilization by combining multiple signals into a single message. Furthermore, users can define signal value tables,

facilitating the mapping of raw signal values meaningful engineering units or states. CANdb++ also excels in network configuration management, enabling users to configure nodes, buses, baud rates, and message routing with ease. It seamlessly integrates with other Vector hardware interfaces like CANoe and CANalyzer, offering a comprehensive solution for network development and testing. With features for import/export, version control integration, validation, simulation, documentation, and reporting, VECTOR CANdb++ stands as an indispensable tool in the arsenal of engineers tasked with designing and validating complex CAN-based systems. TS master.

TABLE I

| S.NO | Table Column Head | | |
|------|-------------------|----------|-------------------|
| | ECU | MESSAGES | SIGNAL |
| 1 | B_C_M | B_C_M_1 | Indicator |
| 2 | T_C_M | T_C_M_1 | Vehicle speed |
| 3 | T_C_M | T_C_M_1 | Throttle position |
| 4 | B_C_M | B_C_M_1 | Iginition |
| 5 | B_C_M | B_C_M_1 | position |

Table1 CAN Data Base

VECTOR CANdb++ is a powerful tool used for managing and editing CAN databases. It's widely used in automotive development for creating, editing, and maintaining databases that define the communication parameters of a Controller Area Network (CAN) bus system. Here's an overview of VECTOR CANdb++ allows users to create new CAN databases from scratch. Users can define message structures, signal definitions, message properties, and other parameters necessary for communication on the CAN bus Users can edit existing CAN databases, making modifications to message structures, adding or removing signals, adjusting signal properties, and updating database attributes. CANdb++ supports importing and exporting database files in various formats, including CANdb (.dbc), FIBEX, AUTOSAR XML, and CSV. This facilitates interoperability with other tools and enables collaboration between different teams within an automotive development. The tool provides features for organizing and managing large databases, including search and filtering capabilities, grouping objects into folders, and version control support. CANdb++ supports signal multiplexing, allowing users to define multiplexed signals and configure the multiplexing scheme within the database. This is useful for optimizing bandwidth usage on the CAN bus and efficiently transmitting multiple pieces of data over a single message. The tool includes features for validating database integrity and verifying compliance with industry standards such as CAN and ISO 11898. Users can perform consistency checks, detect errors, and ensure that the database meets the requirements of the target application. CANdb++ integrates with simulation tools to facilitate virtual testing and validation of CAN communication. It allows users to simulate message traffic, generate test scenarios, and analyze the behavior of the CAN network under different conditions.

RESULT

Seat Belt Reminder System Performance: The CAPL script successfully simulates the behavior of a seat belt system by periodically toggling the seat belt status between fastened and unfastened states. Status updates are displayed in the CAPL console. The implementation of seat belt laws and regulations has resulted in significant improvements in road safety worldwide. Seat belts are one of the most effective safety devices in vehicles, and their proper use can greatly reduce the risk of injury or death in traffic accidents. Reduction in fatalities: Seat belt usage has been associated with a significant reduction in the number of fatalities and serious injuries in car accidents. Studies have shown that wearing a seat belt can reduce the risk of death by about 45

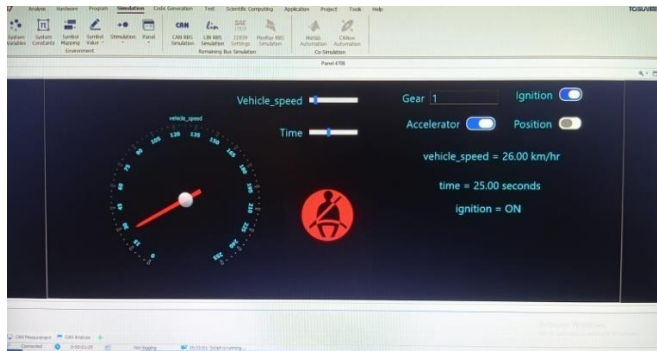

Fig. Test Panel

CONCLUSION

In conclusion, the implementation of seat belt laws and regulations has been a critical component of efforts to improve road safety worldwide. Seat belts are highly effective at reducing the risk of injury and death in motor vehicle accidents, and their proper use is widely recognized as one of the most important safety measures for drivers and passengers. Through the enforcement of seat belt laws, public awareness campaigns, and cultural shifts toward prioritizing safety, seat belt usage rates have increased significantly over the years. This increase in compliance has resulted in tangible benefits, including reductions in fatalities, serious injuries, and associated economic costs. However, despite these advancements, there is still work to be done to ensure universal seat belt usage and further enhance road safety. Continued enforcement of seat belt laws, coupled with ongoing education and awareness initiatives, will be essential for sustaining and building upon the progress made thus far. Additionally, advancements in technology and vehicle safety features offer opportunities to further improve seat belt effectiveness and compliance. Innovations such as seat belt reminders, advanced restraint systems, and automated enforcement technologies can play a role in encouraging greater seat belt usage and reducing the incidence of road traffic injuries. The potential impact of the seat belt reminder system on vehicle safety is discussed, along with possible future enhancements or extensions to the project.

REFERENCES

1. J.D. Febres, S. G. Herrero, S. Herrero, J.M. Gutierrez, J.R.L. Garcia, M.A. Mariscal, "Influence of seat-belt use on the severity of injury in traffic accidents," *European Transport Research Review*, vol. 12, no. 1, 2020, p. 9
2. Hanahara, M. Hitosugi, Y. Tateoka "Education for appropriate seatbelt use required for early-phase pregnant women drivers," *Scientific Reports*, vol. 10, no. 1, 2020, p. 17609
3. G. Agarwal, N. Kidambi, R. Lange, "Seat Belts: A Review of Technological Milestones, Regulatory Advancements, and Anticipated Future Trajectories," in *SAE Technical Paper 2021-01-5097*, United States, 2021.
4. F. Hu, "Robust Seatbelt Detection and Usage Recognition for Driver Monitoring Systems" *ArXiv*, 2022
5. A. M. Tapia, G. S. T. Riveors, J. C. Vargas, M. A. Incacoña, N. F. Valdez, O. V. Anahua, C. R. Mejia, "Use of seat belts among public transport drivers in Tacna, Peru: Prevalence and risk factors," *PLOS ONE*, vol. 16, 2021, pp. 1-13