



# Radar System Using Arduino And Ultrasonic Sensor

<sup>1</sup>Athrava Kulkarni, <sup>2</sup>Mugdha Zope, <sup>3</sup>Harshad Mhaske, <sup>4</sup>Nyacia Pandita, <sup>5</sup>Mayuresh Kharmate, <sup>6</sup>Prof. Amruta More  
<sup>1</sup>Student, Department of Artificial Intelligence and Data Science, Ajeenkya D.Y Patil School of Engineering, Pune  
<sup>2</sup>Student, Department of Artificial Intelligence and Data Science, Ajeenkya D.Y Patil School of Engineering, Pune  
<sup>3</sup>Student, Department of Artificial Intelligence and Data Science, Ajeenkya D.Y Patil School of Engineering, Pune  
<sup>4</sup>Student, Department of Artificial Intelligence and Data Science, Ajeenkya D.Y Patil School of Engineering, Pune  
<sup>5</sup>Student, Department of Artificial Intelligence and Data Science, Ajeenkya D.Y Patil School of Engineering, Pune  
<sup>6</sup>Professor, Department of Artificial Intelligence and Data Science, Ajeenkya D.Y Patil School of Engineering, Pune

**Abstract:** This research explores the development of a cost-effective and efficient Radar System controlled by Arduino, utilizing ultrasonic sensors and servo motors. Traditional Radar Systems, reliant on radio waves, often face limitations such as extended detection times, short ranges, and high costs. In response, this study proposes an innovative approach using ultrasonic sensors, providing a real-time, accurate detection of objects within defined ranges. The system employs an Arduino Uno board, connecting ultrasonic sensors to servo motors for rotational coverage. Visual representations, including object angles and distances, are generated via the Processing IDE, enhancing navigation, positioning, and object identification capabilities. Moreover, integration with an ESP32 cam facilitates IoT-based applications and live streaming, extending the system's utility to include mapping, tracking, and even automatic laser shooting mechanisms. This approach not only addresses the shortcomings of traditional Radar Systems but also offers a versatile, low-cost solution suitable for indoor applications, thereby paving the way for enhanced object detection and obstacle avoidance in various domains.

**Keywords:** Arduino, Ultrasonic sensor, Servo motor, Simulation

## I. INTRODUCTION

Ultrasonic technology has emerged as a cornerstone in the realm of object detection and measurement, revolutionizing numerous industries and applications. At the heart of this innovation lies the fundamental principle that everything, by its very existence, generates sound waves that affect the surrounding air. These waves, operating beyond the audible spectrum of humans, manifest as ultrasonic waves with frequencies surpassing 20 kHz. Central to the functionality of ultrasonic systems are ultrasonic sensors, which employ transducers to convert sound energy into electrical energy. These sensors play a pivotal role in capturing crucial information about an object's position, orientation, and speed. The versatility of ultrasonic technology is exemplified by its application in a myriad of fields, including collision avoidance systems, surveillance, and navigation aids. By circumventing the inherent challenges associated with linear measurements, ultrasonic technology offers a non-contact solution, enabling precise assessments of distances and speeds. Moreover, environmental factors such as temperature exert a significant influence on the speed of sound waves, thereby impacting the properties of reflected waves crucial for analysis. The integration of ultrasonic sensors with processing and Arduino software further amplifies their capabilities, facilitating comprehensive detection and evaluation of multiple parameters. Furthermore, the resemblance of ultrasonic sensors to sonar systems, utilized by bats for navigation in low-light environments, underscores their adaptability and efficacy across diverse scenarios. This introduction sets the stage for a comprehensive exploration of the multifaceted role played by ultrasonic technology in modern detection systems. It emphasizes the transformative impact of this technology, highlighting its efficacy, versatility, and wide-ranging applications across various domains.

## II. DESIGN IMPLEMENTATION

The figure shown below shows the development life cycle of Radar project which involves various step such as design of different components, their testing, their implementation and implementation of entire system and their testing. These steps can be enumerated into following stage:-

- a) Hardware System Design.
- b) Hardware Circuit Design.
- c) Hardware System implementation.
- d) Hardware unit testing.
- e) GUI System Design.
- f) GUI System Implementation.

- g) GUI unit testing.
- h) Entire system integration.
- i) Entire system testing.

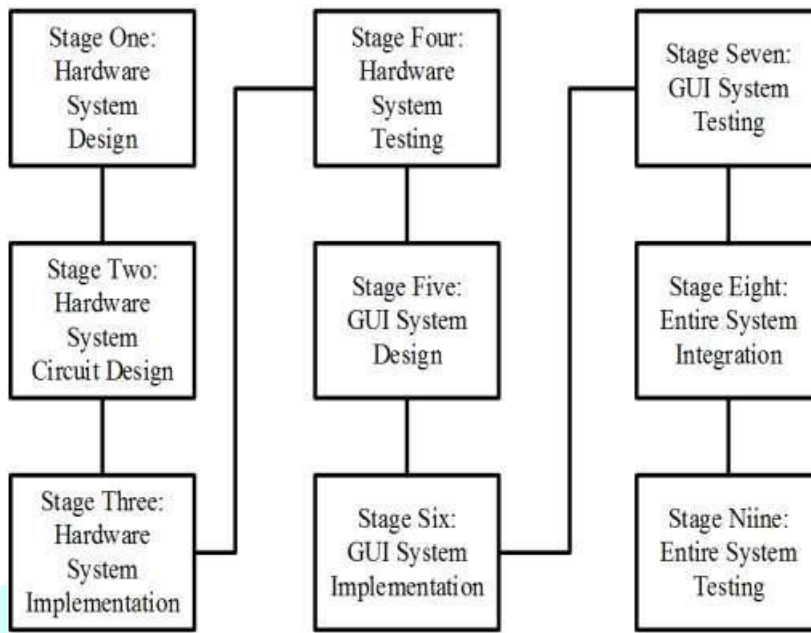

**61) Development Cycle of Radar System**

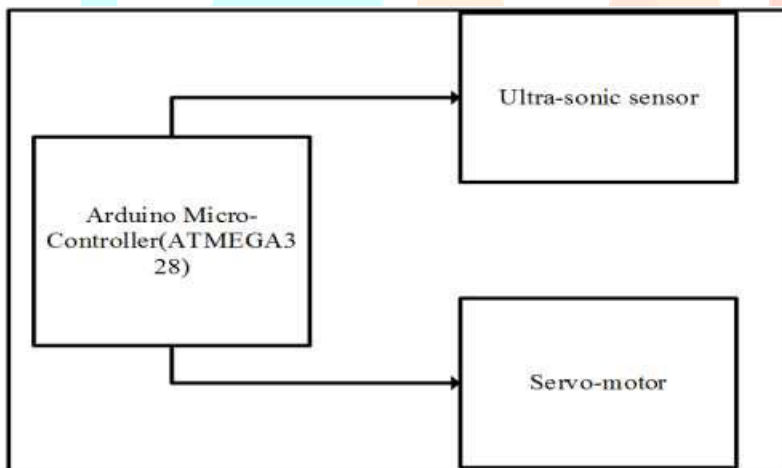

**2)Hardware System Design For Arduino**

**(A)Hardware system design for Arduino:**

Hardware system consist of basically 3 components named as Arduino, servo-motor, and ultra-sonic sensor. Ultrasonic sensor is mounded upon a servo motor which helps it to move and provide it a turning mechanism. Both ultrasonic sensor and servo motor are controlled and powered by Arduino. As given in above figure 2 we can see both ultrasonic sensor and servo motor is powered by Arduino.

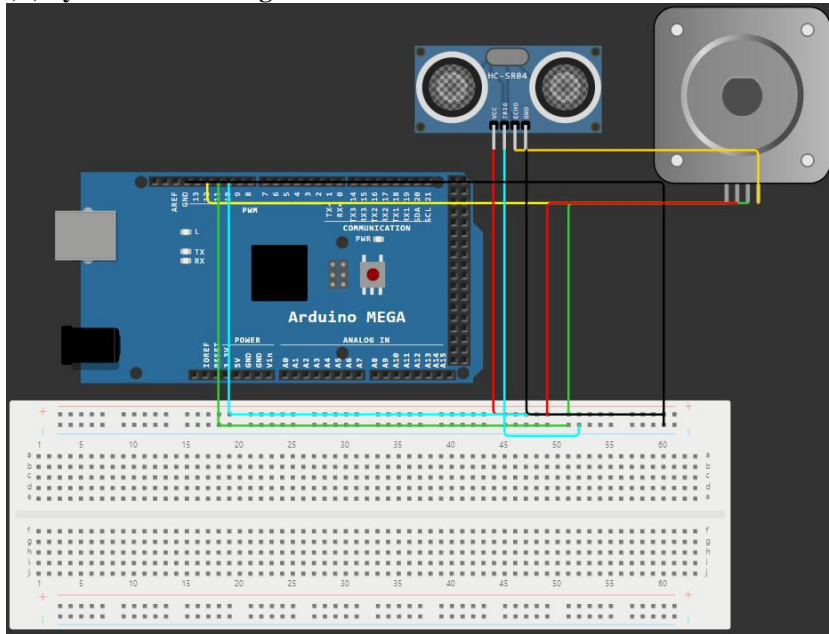
**(B) System circuit design:****3) System Circuit Diagram**

The diagram illustrates the hardware system design created within the Fritzing environment. It elucidates the interconnection among various electronic components. Specifically, the triggering pins of the ultrasonic sensor are linked to the D8 pin of the Arduino, the control line of the servo motor is attached to the D6 pin of the Arduino, and the echo pin is connected to the D7 pin of the Arduino. Additionally, the VCC pins of both the servo motor and the ultrasonic sensor are wired to the 5V pin of the Arduino, while the ground pin of the Arduino is interconnected with the ground pins of both the servo motor and the ultrasonic sensor.

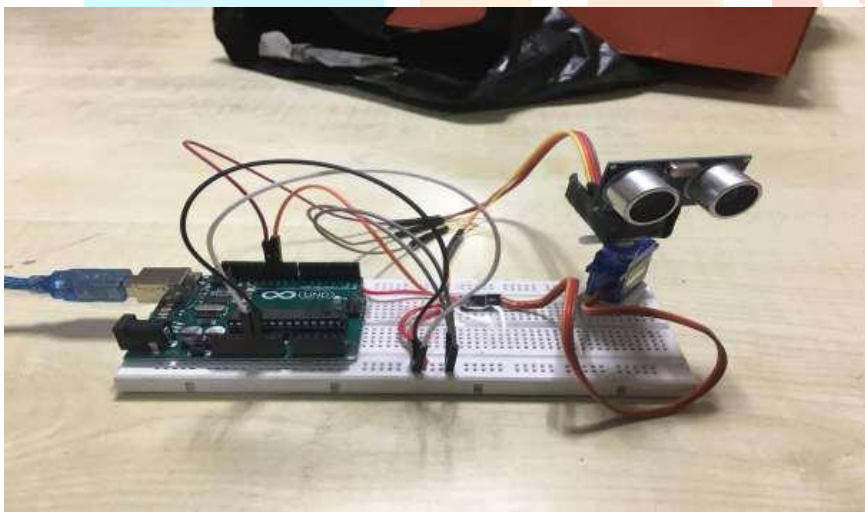
**(C) System circuit implementation on bread board:****4) Breadboard For Hardware System Implementation**

The depicted figure, as presented in Figure 4, illustrates the comprehensive implementation of the hardware system. Notably, the ultrasonic sensor module is positioned atop a servo motor, which, in turn, is situated above a breadboard. Meanwhile, the Arduino board is securely placed within the breadboard, facilitating seamless connectivity between the components. To prevent potential instability during servo motor movements, both the Arduino board and the servo motor are firmly affixed to the breadboard. In the software realm, the Arduino Integrated Development Environment (IDE) serves as the platform for coding and uploading tasks. The Arduino code, crafted within this environment, functions to interpret the servo motor's position data and subsequently computes the distance to the nearest object within its path. This iterative process ensures efficient object detection and facilitates real-time monitoring capabilities within the system.

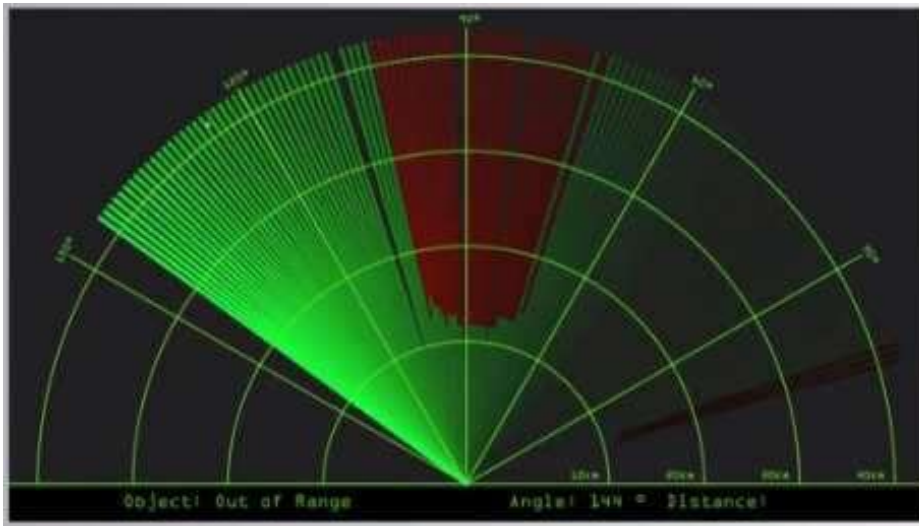
**(D) GUI system design and implementation:****III. WORKING**

The objective of this project is to determine the distance, position, and speed of an object located at a specific distance from the sensor. Utilizing an ultrasonic sensor, ultrasonic waves are emitted in various directions through the rotation facilitated by a servo motor. As these waves propagate through the air, they encounter objects and are subsequently reflected back to the sensor. The sensor detects these reflected waves, analyses their characteristics, and then presents the findings on a screen, showcasing parameters such as the distance and position of the object. To accomplish this task, the Arduino Integrated Development Environment (IDE) is employed to write and upload code onto the Arduino board. This code facilitates the sensing of the servo motor's position, which is then relayed to the serial port alongside information regarding the distance to the nearest object obstructing its path. The output from the sensor is visualized using processing software, culminating in a final display on the screen. This integrated approach enables the accurate assessment and visualization of object parameters, contributing to the project's overarching goal.

**IV. RESULTS AND CONCLUSIONS**

This paper outlines the development of a radar system utilizing Arduino, a servomotor, and an ultrasonic sensor to detect and visually represent the position and distance of obstacles in its path. This system holds significant potential for integration into robotics applications, serving as an effective tool for object detection and avoidance. Additionally, it offers utility in intrusion detection systems, enabling the identification and monitoring of various-sized objects within a designated area. The operational range of the system is contingent upon the type of ultrasonic sensor employed. For this project, the HC-SR04 sensor was utilized, boasting a detection range spanning from 2 to 40 cm. This range provides adequate coverage for many practical scenarios, demonstrating the versatility and effectiveness of the implemented radar system. In conclusion, the developed radar system presents a viable solution for object detection and visualization, with promising applications across robotics, security, and various other domains. Further advancements and refinements in sensor technology hold the potential to enhance the capabilities and expand the operational scope of such systems in the future.

**V. ACKNOWLEDGEMENT**

We would like to thank my guide professor Amruta More and professor Shakti Kaushal for their expert advice and encouragement through this wonderful project.

**VI. REFERENCES**

- [1] G. Bhor, P. Bhandari, R. Ghodekar and S. Deshmukh, "Mini Radar," International Journal of Technical Research and Applications, pp. 68-71, 2016.
- [2] D. B. Kadam, Y. B. Patil, K. V. Chougale and S. S. Perdeshi, "Arduino Based Moving Radar System," International Journal of Innovative Studies in Sciences and Engineering Technology (IJISSET), vol. 3, no. 4, pp. 23-27, 2017.
- [3] T. P. Rajan, K. K. Jithin, K. S. Hareesh, C. A. Habeeburahman and A. Jithin, "Range Detection based on Ultrasonic Principle," International Journal of Advanced Research in Electrical, Electronics and Instrumentation Engineering, vol. 3, no. 2, pp. 7638 7643, 2014.
- [4] P. S. Abhay., S. K. Akhilesh, P. Amrit and Kriti, "A Review on Ultrasonic Radar Sensor for Security system," Journal of Emerging Technologies and Innovative Research (JETIR), pp. 137-140, 2016.
- [5] P. P. Arun, M. A. Sudhakar, P. Megha Sunil and S. S. Balaji, "Ultrasonic Distance Meter," SVERIAN Scientific, pp. 1-4, 2015.
- [6] O. V. Amondi, "Collision Avoidance System," The University Of Nairobi, 2009.
- [7] Shamsul A., Tajrian M., "Design of an Ultrasonic Distance Meter", International Journal of Scientific & Engineering Research, pp. 1- 10, March 2013.

[8] U. Papa, G. D. Core, "Design of sonar sensor model for safe landing of an UAV", Proc. IEEE Metrol. Aerosp., pp. 346-350, Jun. 2015.

[9] Abbay P., Akhilesh S., Amrit P., and Prof Kriti, "A Review on Ultrasonic Radar Sensor for Security system", Journal of Emerging Technologies and Innovative Research (JETIR), April 2016.

[10] Wikipedia

