



# DETECTING THE SPEED BREAKER AND REDUCING THE SPEED OF THE VEHICLE THROUGH RF MODULE

Dr. M. VIJAYA LAXMI<sup>1</sup>, T. SAI CHARAN REDDY<sup>2</sup>, P. ANIL<sup>3</sup>, M. GANESH<sup>4</sup>, N. YASHO VARDHAN<sup>5</sup>

<sup>1</sup>Professor, <sup>2,3,4,5</sup>UG Students

<sup>1</sup>Department of Electronics and Communication Engineering,

<sup>1</sup>Chadalawada Ramanamma Engineering College (Autonomous), Tirupati, A.P, India

**Abstract:** This paper presents the implementation of an Arduino Uno, RF Module, IR Sensor, Vibrator Sensor, GSM, GPS, LCD, DC Motor, L293DIC Driver, and buzzer. Bad visibility conditions which occur due to fog in winter or night time driving are the major causes of road accidents in India. The principle cause for such accidents is the unintentional ignorance of speed breakers which may be due to the driver not being able to detect them or may be due to over speeding of vehicles. This project brings an idea of a speed breaker system that helps in detecting presence of speed breakers well in advance so that such accidents can be avoided. This system makes use of a RF module that warns the person who is driving about the existence of a speed breaker in proximity, with this it assists in automatically reducing the vehicle's speed if no action is taken by the driver in time. Through Global Positioning System (GPS) the locations of speed breaker can be sent to cloud and stored for future avoidance of road mishaps.

**Keywords--** Arduino Uno, Vibrate Sensor, IR Sensor, Motor driver, DC motors, RF Module, GSM, GSM, LCD and buzzer

## I.INTRODUCTION

Due to poor visibility conditions during winters and during night time, it becomes strenuous for a driver to notice speed breakers. This increases the chances of accidents which may cause serious injuries to the driver as well as the passengers and will also cause destruction to the vehicle. Thus, we develop a system which will assist the driver to become conscious of the existence of a speed-breaker in proximity and alter or change the vehicle's speed in order to refrain from the occurrence of an accident.

This Prototype can be derived by using a RF module that consists of a Transmitter and a Receiver. The RF Transmitter which transmits RF signals is fixed to the speed breaker and which is received by an RF Receiver which is connected to the vehicle. The Automatic Smart Speed Breaker (ASSB) is a novel system designed to enhance road safety by dynamically adjusting speed breakers according to the speed of approaching vehicles. The RF Receiver receives signals from RF Transmitter and makes the driver aware about the existence of a speed breaker in proximity through audio or text messages or buzzer. The RF Receiver sends signal to the motor through Arduino IDE to automatically decrease the vehicle's speed.

Using RF Module is used to detect the speed breaker and accident detection has the following advantages:

- By detecting the proximity of a speed breaker and automatically adjusting the vehicle's speed, the system helps prevent accidents caused by drivers approaching speed breakers at high speeds.

- The audio, text messages, or buzzer alerts provided by the system make drivers more aware of upcoming speed breakers, reducing the likelihood of sudden braking or swerving.
- With the system handling the speed adjustment automatically, drivers experience less stress and cognitive load, allowing them to focus more on the road ahead and other potential hazards.

The Automatic Smart Speed Breaker (ASSB) prototype utilizes RF technology to detect speed breakers and adjust vehicle speed, enhancing road safety by preventing accidents. Through customizable alerts, it informs drivers of upcoming obstacles, reducing the risk of sudden. Real-time adaptation ensures optimal safety, while cost-effective components make it accessible for implementation in various environments.

## LITERATURE SURVEY

- 1] C. Fernandez, M. Gavilan, D. F. Llorca, I. Parra, R. Quintero, A. G. Lorente, Lj. Vlacic, M. A. Sotelo, "Free Space and Speed Humps Detection using Lidar and Vision for Urban Autonomous Navigation", The paper presents a real-time free space detection system using lidar and a camera. The lidar measures 4 horizontal layers, integrated over time based on vehicle motion. It detects Spanish speed humps by evaluating slope shape with lidar and zebra crossings with the camera.
- 2] Sathish Kumar Soundararaj, P. Bagavathi Sivakumar and V. Ananthanarayanan, "Slow Speed Alert for Speed Breakers and Potholes Using IoT and Analytics in the Context of Smart Cities", In this project they use a Slow Speed Alert is a mobile application, which collects GPS and accelerometer sensor data, and stores the GPS coordinates whenever the anomaly (Speed Breaker or Pothole) is detected. Then this stored data is used to provide voice alert prior to reaching speed breaker or pothole.
- 3] Punyaban Patel, Uma Valle, Navya Kola, Hari Priya Sathyam, explains to develop in this project they use a Slow Speed Alert is a mobile application, which collects GPS and accelerometer sensor data, and stores the GPS coordinates whenever the anomaly (Speed Breaker or Pothole) is detected. Then this stored data is used to provide voice alert prior to reaching speed breaker or pothole.
- 4] Rahul Ramakrishnan, Ayusha Pendse, Chetna Sharma, Priya Chimurkar, "Speed Breaker Detection and Mapping using IoT", in this paper explained about a self-improving system minimizes user involvement, detecting speed breakers by measuring height differences between road and vehicle. GPS coordinates stored online notify users when approaching, enhancing accuracy over time
- 5] Poonam Yadav, Akshay Kamble, Prashant Yadav, addressed that a self-improving system with minimal user involvement and aims to cover nearly all the drawbacks of the current solutions. It suggests speed breaker detection by measuring the difference in the height between the road level and the vehicle. In this approach, GPS coordinates are stored in an online database system that is available to the public through a portal. When the vehicle is at a predefined distance away from the speed breaker, the user is notified resulting in improved accuracy with every usage.
- 6] Kumaravel A, Tharani R, Thillaikarasi G, Varsha A, "Automated Speed Breaker to Control The Speed of the Vehicle Based on IoT", In this paper they used an iron-made flat speed breaker rises via embedded system control. Arduino monitors speed, activates breaker via proximity sensors if exceeded, and warns driver with traffic light signal. Excess speed triggers image capture for RTO fines.
- 7] Md. Mamunur Rahman, Md. Rahi, Md. Abdur Razzaque, "Federated Learning for Accurate Detection of Speed Breakers on The Road", In this paper they use come forward with a system offering highly accurate detection of speed-breakers by applying federated learning. Our system detects speed-breakers and generates a warning to the driver. After the detection of any speed-breaker, feedback is sent to the cloud server. The server aggregates all the pieces of information and gets updated each time a vehicle is passing a speed-breaker.

- 8] Syaza Nadia Hirudin, Azlina Ahmadi Julalhi and Tan Ping addressed that to have An Integrated Speed Bump Detector to notify road users using the Internet of Things (IoT) has been proposed to help road users to detect speed bumps earlier by getting notified through sound from the buzzer and red light from an LED. This also increases the safety of road users during their trips and provides information if a speed bump is approaching. The ultimate goal of this project is to prevent an accident from occurring during road trips and to promote a careful attitude among road users.
- 9] Dr. N. Karpagam Haridharshini B, Priyadharsini P, Vaishnavi T, “Automatic Speed Breaker Using IoT”, addressed automated speed breaker activated on demand and for emergency vehicles. It employs a hemispherical sheet metal breaker connected to a screw jack for rotation. Transmitter and receiver enable radio frequency control, with manual configuration via keypad. This ensures flexible road obstacle management.
- 10] Jahnvi Joshi, Sandeep Kumar, Surya G, R. P. Bharathwaja Rao, Sunderesan V, commented that introduces a real-time free space detection system employing a medium-cost lidar sensor and a low-cost camera. It determines the sensors' extrinsic relationship through offline calibration. Lidar measures across 4 horizontal layers with a 3.2-degree vertical resolution, integrating them over time based on vehicle motion, targeting Spanish speed humps.

### III. EXISTING METHOD

The Smart Speed Breaker project presents an innovative approach to curb speeding on roads. Utilizing a combination of hardware and software components, including a Raspberry Pi camera, a sound sensor, and a servo motor, the system detects over-speeding vehicles. In real-time, it adjusts the speed breaker accordingly, providing an immediate response to ensure road safety. This integrated solution effectively addresses the challenge of speeding, offering a proactive measure to mitigate potential accidents and enhance overall traffic management. By leveraging advanced technology, the project contributes to creating safer road environments and fostering responsible driving habits among motorists.

### IV. PROPOSED BLOCK DIAGRAM

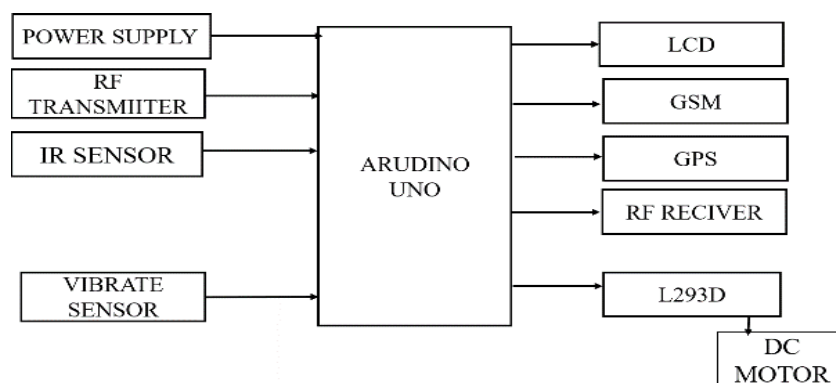

Figure 1: Block Diagram of block diagram

### V. PROPOSED METHOD

The Proposed Automated Smart Speed breaker system with RF transmitter which will be surfaced and will show up only if the vehicle speed is higher than permissible limits. To control lift of the speed breaker used. Arduino based RF frequency-based speed breaker system is Depending upon the speed of the vehicle and the distance of the vehicle from the speed breaker, the Arduino board sends a signal to buzzer to start the beep sound to warn the driver that its speed is beyond the permissible speed.

The proposed speed breaker will use Arduino uno instead of other microcontroller and the sensing vehicles will take place only with the help of the sensor. The sensor used in the speed breaker is IF sensor which will be very affordable to use instead to use RF sensor and it will receive the signal the vehicle which is going to come the received signal will pass through speed breaker detection.

## VI. HARWARE EXPLANATION

A motor driver, DC motor, buzzer, IR Sensor, Vibrate Sensor, Arduino Uno microcontroller boards, GPS, GSM, LCD, and RF Module is used in the detecting the speed breaker and reducing the vehicle speed using the RF Module. As shown in figure 2.

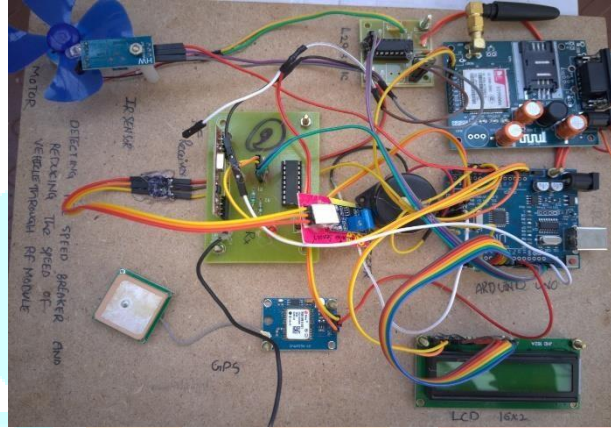

Figure 2: Hardware setup

Step 1: Start

Step 2: Initialize the Arduino controller

Step 3: Write the Arduino C programmer based on sensors in the Arduino IDE.

Step 4: Implement speed breaker detection using a TX and RX module. When the RX frequency nears the TX frequency, trigger a buzzer alert. Connect the TX module to one digital pin and the RX module to another digital pin on the Arduino.

Step 5: Measure vehicle speed between IR sensors. If high speed is detected, reduce vehicle speed using an RPM motor. Connect the IR sensors to digital pins on the Arduino, and connect the RPM motor to a PWM pin for speed control.

Step 6: Implement accident detection using a vibration sensor. When a vibration is detected, update the location based on GPS. Connect the vibration sensor to a digital pin on the Arduino, and connect the GPS module to the appropriate serial pins for communication.

Step 7: Stop

This plan outlines the basic steps and connections needed to implement the system. Make sure to adjust the specific pins and configurations based on the components you are using and any additional requirements.

## RESULTS

The Hardware components of the Detecting the Speed Breaker and Reducing the Speed of Vehicle Through RF Module are connected and the power supply is given and the Hardware setup is shown in figure 2.

Step 1: When the power supply is given, it shows Detecting the Speed Breaker, Speed & Vibration with SMS alert While Accident is occurred.

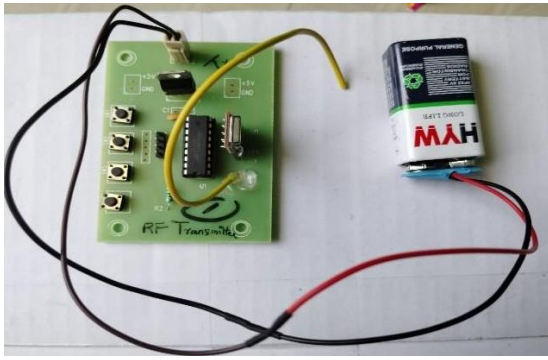

Figure 3: Hardware setup on Speed Breaker

Step 2: The RF Transmitter is placed where the speed breaker is located. The Hardware setup on Speed Breaker is shown in below figure 3.



Figure 4: Initially Displaying the Liquid Crystal Display (LCD)

Step 3: The LCD displays information about vehicle Speed (RPM), Vibration (N or Y), Speed Breaker (Y or N). The Initially Displaying the LCD is shown in the figure 4.



Figure 5: Speed Breaker is detected and Automatically vehicle speed is reduced

Step 4: When the Speed Breaker is detected, it displays vehicle speed is reduced and Automatically Reduce the Speed of the Vehicle through L293DIC. The Speed Breaker is detected and Automatically vehicle speed is reduced is shown in the above figure 5.



Figure 6: Vibration is Detected

Step 5: When Accident is occurred then Vibration (VB: Y) is detected and the Vibration Detected is shown in figure 6.

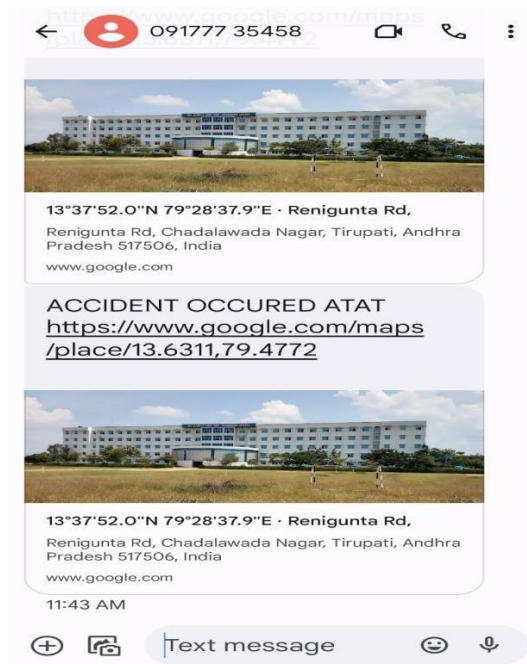

Figure 7.a: Message alert and Live Location

Step 5: GPS sends message when accident is detected with live location. The Message alert and Live Location is shown in the figure 7.a and 7.b.

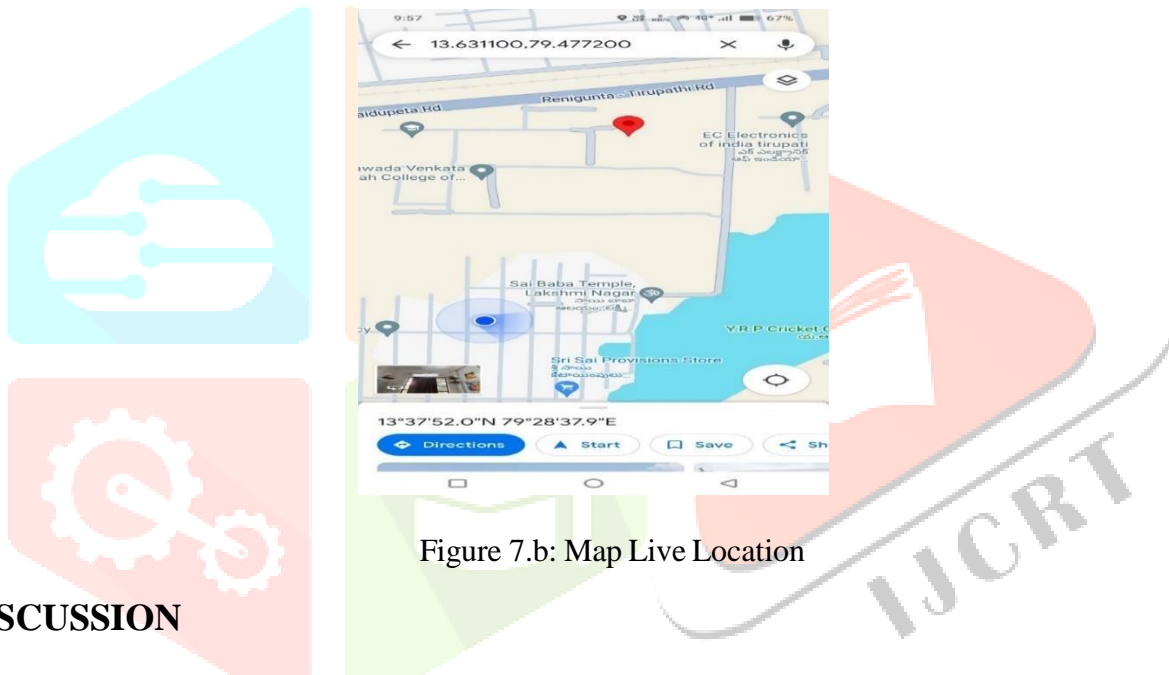

Figure 7.b: Map Live Location

## VII. DISCUSSION

Designing a project on Detecting the speed breaker based on the vehicle speed through RF Module Using IOT, Arduino, GSM, GPS and by using some sensors can be done by following procedures.

**Define the project requirements:** The first step in designing the project is to define the project requirements, such as to improve road safety by dynamically adjusting vehicle speed in response to approaching speed breakers, particularly in poor visibility conditions and to decrease the number of road accidents happening in now a day.

**Identify the necessary hardware components:** The next step is to identify the necessary components, such as the Arduino Board, RF Module, IR Sensors, Vibrator Sensors, LCD, L293D IC, DC Motor, GPS and GSM.

**Set up the hardware components:** The hardware parts need to be connected and configured correctly. All other sensors should be attached to the proper pins, and the GSM and GPS modules need to be linked to the Arduino board.

**Develop the software:** Writing the code to operate the hardware components, such as gathering data from sensors, sending SMS messages, updating location coordinates using GPS, and all part of software development.

**Test the system:** Testing the system is crucial after software development to make sure everything is functioning as it should.

**Deploy the system:** The Smart Speed Breaker system must have RF Transmitters installed on speed breakers and RF Receivers integrated into Vehicle in order to be deployed. Testing makes ensuring that functioning and communication are smooth.

**Monitor and maintain the system:** Tracking system performance is part of monitoring, whereas routine maintenance entails updates and inspections. Constant feedback spurs development, and following the law guarantees safety and compliance.

## IX. ADVANTAGES

- Enhanced road safety by detecting speed breakers in advance, reducing accidents caused by poor visibility and speeding.
- Prompt warning to drivers about nearby speed breakers using the RF module.
- Automatic speed reduction if the driver fails to respond to warnings, preventing accidents.
- Utilization of GPS for storing speed breaker locations in the cloud, facilitating future avoidance of road mishaps.
- Overall improvement in road safety and reduction in accidents, particularly during bad visibility conditions.

## X. LIMITATIONS:

**RF Signal Reliability:** Potential interference, signal attenuation, and range limitations may affect the consistent detection of speed breakers.

**Accuracy of Detection:** Varying Road conditions and speed breaker types could challenge the system's ability to reliably identify obstacles.

**Response Time:** Delays in warning drivers or adjusting vehicle speed may impact the system's effectiveness in preventing accidents.

**Integration Challenges:** Compatibility with vehicle systems and ensuring seamless integration pose technical hurdles.

**Cost and Maintenance:**

High implementation costs and ongoing maintenance requirements could limit widespread adoption. **Regulatory**

**Compliance:** Adherence to vehicle safety standards and data privacy regulations presents legal considerations.

## XI. CONCLUSION

We Proposed a Speed Breaker detecting System using Arduino technology. By sequentially initializing the Arduino controller and writing the necessary code, users can integrate sensors and modules to detect speed breakers, measure vehicle speed, and respond to potential accidents. The incorporation of TX and RX modules for speed breaker detection, coupled with IR sensors for speed measurement, forms the backbone of the system's functionality. Additionally, the integration of a vibration sensor and GPS module enhances the system's capabilities by enabling to send message alert of real-time accident detection and location tracking. Factors such as power consumption, durability, and scalability should be considered during development and testing phases. Ultimately, the speed breaker system has the potential to significantly enhance road safety by alerting drivers to speed breakers, controlling vehicle speed, and responding effectively to accidents with careful execution and optimization, this system can contribute to reduce accidents and improving overall safety on the roads.

## XII. FUTURE SCOPE

The proposed approach acknowledges the factors like poor visibility and speeding can lead drivers to miss speed breaker signs, a major cause of accidents in India. The technology utilizes an RF module to alert drivers in advance about the presence of speed breakers, enabling them to adjust their speed accordingly. The device can capture and transmit speed breaker locations to the cloud using GPS technology, contributing to the development of a comprehensive database for future reference and implementing in optimized platform like using Matlab or machine learning in computer vision.

## XII. REFERENCE

- [1] Jahnvi Joshi, Sandeep Kumar, Surya G, R. P. Bharathwaja Rao, Sunderesan V, "Smart Speed Breaker", AMC Engineering College Bangalore, IJARIII, Volume No.9, Issue No.3,2395-4396,2023.
- [2] Punyaban Patel, Uma Valle, Navya Kola, Hari Priya Sathyam, "Smart Speed Breaker Control System Based on Time Demand Using Arduino Nano Micro- controller", Dept. Of CSE, CMR Technical Campus, India, Volume:04/Issue:06/June-2022.
- [3] Poonam Yadav, Akshay Kamble, Prashant Yadav, "Automatic Speed Breaker", International Journal for Research in Applied Science & Engineering Technology (IJRASET), Volume.:10, Issue VI, June 2022.
- [4] Syaza Nadia Hirudin, Azlina Ahmadi Julalhi and Tan Ping, "Integrated Speed Bump Detector to notify road users using Internet of things", University Malaysia Sarawak,94300 kota, Samarahan, Sarawak, Malaysia.
- [5] Dr. Karpagam, Haridharshini B, Priyadarshini P, Vaishnavi T, "Automatic Speed Breaker Using IoT", International Research Journal of Engineering and Technology (IRJET), Volume: 07, Issue: 04, Apr2020.
- [6] Md. Mamunur Rahman, Md. Rahi, Md. Abdur Razzaque, "Federated Learning for Accurate Detection of Speed Breakers on The Road", Green University of Bangladesh, Dhaka, Bangladesh,978-1-6654-0489-1, IEEE.
- [7] Kumaravel A, Tharani R, Thillaikarasi G, Varsha A, "Automated Speed Breaker to Control the Speed of the Vehicle Based on IoT", International Research Journal of Engineering and Technology (IRJET), Volume: 07, Issue: 07, July 2020.
- [8] Rahul Ramakrishnan, Ayusha Pendse, Chetna Sharma, Priya Chimurkar, "Speed Breaker Detection and Mapping using IoT", Electronics Engineering Department Sardar Patel Institute of Technology Mumbai, India, 978-1-7281-5821,2020, IEEE.
- [9] C. Fernandez, M. Gavilan, D. F. Llorca, I. Parra, R. Quintero, A. G. Lorente, Lj. Vlacic, M. A. Sotelo, "Free Space and Speed Humps Detection using Lidar and Vision for Urban Autonomous Navigation", 2012 Intelligent Vehicles Symposium Alcalá de Henares, Spain, June 3-7, 2012, IEEE.
- [10] Jahnvi Joshi, Sandeep Kumar, Surya G, R. P. Bharathwaja Rao, Sunderesan V, "Smart SpeedBreaker", AMC Engineering College Bangalore, IJARIII, Volume No.9, Issue No.3,2395-4396,2023.