



Real-Time Vehicle Overload Alert, Insurance Verification, and Challan Status Monitoring System

Dr. Patil V. V.¹, Mr. Mahesh V. Khandge², Ms. Shrutika S. Chavan³, Mr. Pankaj M. Pandhare⁴

Asst. Prof., Department of Electronics and Telecommunication Engineering¹,

Rajiv Gandhi College of Engineering, Karjule Harya, Tal. Parner, Dist. Ahmednagar, Maharashtra, India.

Students, Department of Electronics and Telecommunication Engineering^{2,3,4},

Rajiv Gandhi College of Engineering, Karjule Harya, Tal. Parner, Dist. Ahmednagar, Maharashtra, India.

Abstract: In the contemporary landscape of transportation and road management, ensuring road safety and regulatory compliance is of paramount importance. The project, titled “Real-time Vehicle Overload Alert, Insurance Verification, and Challan Status Monitoring System,” presents an innovative solution to address these concerns. This project harnesses the power of modern technology, with an Arduino micro-controller at its core, integrated load sensors on roadways, RFID receivers, and GSM communication, to create a comprehensive, real-time monitoring system. Key components of the system include the Arduino micro-controller, which serves as the central processing unit, load sensors installed in the road to monitor vehicle weight, a GSM alert system to notify authorities of vehicle overloads, RFID receivers for checking pending Challan and insurance status, and RFID cards to store vehicle-related data. The objectives of this project are to enhance road safety by detecting and preventing vehicle overloading, improve traffic management by enabling real-time monitoring of overweight vehicles, ensure compliance with insurance and Challan regulations, and streamline data access for authorized personnel. By achieving these objectives, the system aims to make road travel safer, more organized, and more efficient for both road users and authorities responsible for maintaining traffic order. The “Real-time Vehicle Overload Alert, Insurance Verification, and Challan Status Monitoring System” represents a significant advancement in road safety and compliance management, leveraging cutting-edge technology to create a safer and more regulated road environment. This project has the potential to reduce traffic accidents, alleviate road congestion, and enhance the overall quality of transportation systems.

Keywords: Arduino Microcontroller, GSM alert system, RFID receivers, GSM communication.

I. INTRODUCTION

In today's rapidly evolving transportation landscape, ensuring compliance with vehicle load limits, insurance requirements, and pending Challans has become paramount for maintaining road safety and regulatory standards. To address this critical need, we present the “Real-time Vehicle Overload Alert, Insurance Verification, and Challan Status Monitoring System” - an innovative solution leveraging Arduino microcontroller technology. This system incorporates advanced load sensors strategically positioned on roads to accurately calculate the weight of passing vehicles. When a vehicle exceeds its designated weight limit, an automatic GSM alert is promptly dispatched to the relevant authorities, facilitating timely intervention and ensuring adherence to road safety regulations. In addition to load monitoring, the system employs RFID receivers for comprehensive verification of each vehicle's compliance status. It seamlessly cross-references against databases to ascertain any pending challenges or gaps in insurance coverage. This real-time verification process is seamlessly integrated into the vehicle's existing RFID card, streamlining record-keeping and ensuring instant access to critical compliance information. By integrating these components, our system offers a comprehensive and proactive approach to enhancing road safety and regulatory compliance. The seamless coordination between load sensors, Arduino microcontrollers, GSM technology, and RFID verification not only provides real-time insights but also enables efficient and accurate monitoring of vehicle compliance, significantly reducing the potential for accidents and regulatory violations. Through this project, we aim to contribute to a safer and more regulated transportation ecosystem, ultimately leading to reduced accidents, enhanced road safety, and improved overall traffic management.

II. LITERATURE SURVEY

• **Vehicle overloading detection and protection using Raspberry Pi and IoT applications.** Was proposed by Prof. Mr. Shardul Singh Gurjar, and Dr. Ravi Mishra that the growth of every country's economy is measured by the growth of its transport infrastructure. With the gradual development of the economy, the scale of the transportation industry continues to expand. The problem of overload in vehicle transport has emerged. Therefore, how simple and convenient to know the vehicle load and how to effectively limit overload has become a key issue. Vehicle load control system integration device can detect conveniently vehicle load to prevent overloading of vehicles and improve vehicle safety and it can effectively reduce heavy work of the vehicle load testing station and improve work efficiency in the transport sector. advertise.

• **IoT-based vehicle load balancing accident detection** Ashwini Gulhane, Ketan Haridas, Poonam Andhare, Nilesh Yadav, Asst. Prof. Tushar Phadtar in this project, proposes a system implementing an IOT-based vehicle load balancing and accident detection. This system uses a load cell sensor, vibration sensor, web camera, Arduino microcontroller, and Android app. Our application focuses on providing them with more convenience with the vehicle. It provides loadbalancing tracking information to the admin so that they may not get overloaded. Also, we will be detecting the accident capture the image, and send it to the admin. Design a load balancing system, which will track the load of the vehicle using a load cell sensor. Design a vehicle accident detection system, which will detect the accident of the vehicle using a vibration sensor and capture the vehicle accident image through a camera.

• **An IoT monitoring design system of road overload vehicles based on Raspberry Pi** Mortada Mohamed abdulwahab, Marwa Hassan, Zeinab Ibrahim, Abuelgasim f. Abuelgasim, Noon J. Moukhtar overload vehicles are the basic challenge of road users because they cause much harm to roads and accidents on the roads. There are many who have died every day due to the collapse of roads. Automatic monitoring systems became necessary and highly demanded to overcome this problem. The proposed design in this paper has a low cost and it has a simple structure. The system establishes a database to archive all the cases of infringing the allowed legal weight limit of the road. The camera captures an image when the vehicle's weight is out of the allowed limit.

• **Design and development of automatic vehicle overload control system** Bhagwat Dayal (Ph.D.), Gezahegn Tibebe traffic accidents are on the increase in Ethiopia and it has resulted in unattainable crisis on economic, social also vehicular aspects. From various causes of the accidents, overloading of the vehicle takes the lion allotment. Effects of the overloading of the vehicle encompass human life being in drastic danger, unimaginable injuries to the passengers, and individual and government economic crises. Besides service life of the vehicle will decrease and tires will be more prone to wear, steering control will become more difficult and vehicles take longer to react to braking, decreasing safety and driving comfort of the vehicle. • Avoid overloading in trucks using IOT with fuel cutoff p. Leon Dharmadurai, a. Jegatheeswaran, S. Muthumanikandan, D. Naveen, S. Sunil the objective of this project is to detect the load of the vehicle and indicate. This project is very useful to the vehicle owner in order to measure the load of the vehicle. The growth of every country's economy is measured by the growth of its transport infrastructure. With the gradual development of the economy, the scale of the transportation industry continues to expand. The problem of overload in vehicle transport has emerged. Therefore, how simple and convenient to know the vehicle load and how to effectively limit overload has become a key issue. Vehicle load control system integration device can detect conveniently vehicle load to prevent overloading of vehicles and improve vehicle safety and it can effectively reduce heavy work of the vehicle load testing station and improve work efficiency in the transport sector. 4th YEAR 2023-24 DEPARTMENT OF ELECTRONICS AND TELECOMMUNICATION Rajiv Gandhi College of Engineering.

• **Design of overloading detection systems on vehicles using Arduino** M.Z. Rohim, E. Wijayanti, A.C. Murti Developing countries such as Indonesia are currently continuously conducting development activities in the economic sector. The role of transportation facilities is very important. The reason is that economic movement is not only centered on one particular area but also reaches out and involves other regions. Distribution of goods and services requires safe and convenient transportation and good road infrastructure. In practice, many heavy vehicles carry a very excessive transport load. This is due to the large distribution needs of goods to minimize operational costs. The negative impacts of overloading include the risk of accidents and road damage. This study aims to use a prototype method by utilizing the implementation of a load control system using a proximity sensor run by Arduino UNO. This concept utilizes proximity sensors to regulate transportation loads according to the standards of the Republic of Indonesia and monitor violations in real-time. The results of the study resulted in a prototype capable of detecting overload based on load height and suspension changes for loads.

• **Vehicle overloading:** a review Anusha Gaira, Alima Parveen, Drishti Dabral, Jaishree Goyal, ms. Rekha Rani the growth of every nation's economy is estimated by the evolution of its transport substructure. With the moderate development of the economy, the scale of the transportation industry continues to inflate. Vehicle overloading is illicit exceeding of maximum allowed weight of vehicles, is a serious problem both in developing and developed countries around the world. This paper basically highlights the work done in determining the problems caused due to overloading in vehicles and the technologies used for monitoring, detecting, and controlling overload in the vehicles. It also identifies and discusses the efforts undertaken by different researchers using different technologies like GSM, GPS, RFID, BOT (Build Operate Transfer) projects, WIM (weigh-in-motion), FOS (Fiber Optic Sensor), IoT (internet of things), and geophone that proposes a solution for boosting public transportation management services.

BLOCK DIAGRAM

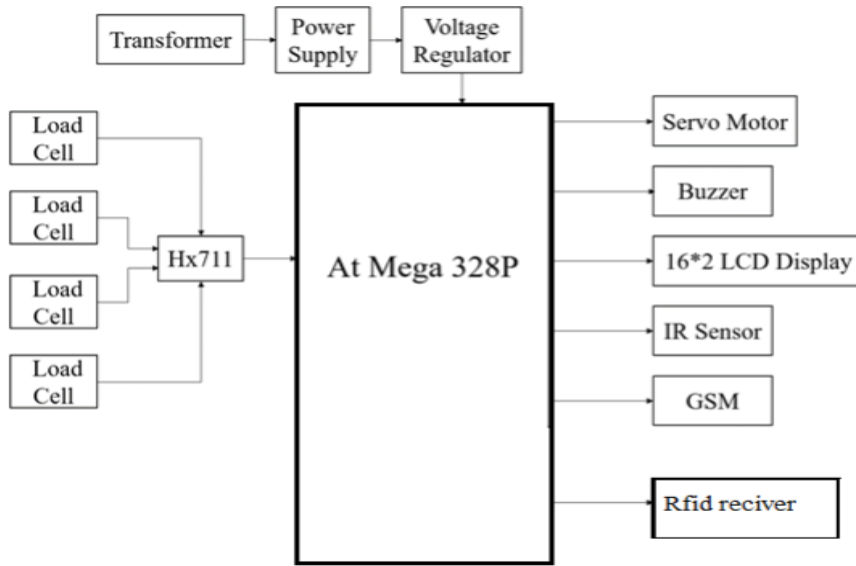

Fig.1 block diagram

BLOCK DIGRAM DESCRIPTION:

- Transformer: Converts the mains voltage to a lower voltage that is safe to use for the electronic components of the system.
- Power supply: Provides a stable and regulated power supply to the electronic components of the system.
- Voltage regulator: Ensures that the voltage supplied to the load cell is constant, regardless of the fluctuations in the mains voltage.
- Load cell: Measures the weight of the load on the vehicle.
- Buzzer: Sounds an alarm when the vehicle is overloaded.
- H6711: A 24-bit analog-to-digital converter that converts the output signal from the load cell into a digital signal that can be read by the microcontroller.
- ATmega328P: A microcontroller that controls the operation of the system.
- Display: Shows the weight of the load on the vehicle.
- GSM module: Sends an SMS message to the vehicle owner or a designated authority when the vehicle is overloaded.
- RFID reader: This reader will be used to read the RFID tag on the vehicle’s registration certificate.
- Vehicle RFID card: This card will store the vehicle’s registration information and insurance status.

FLOWCHART:

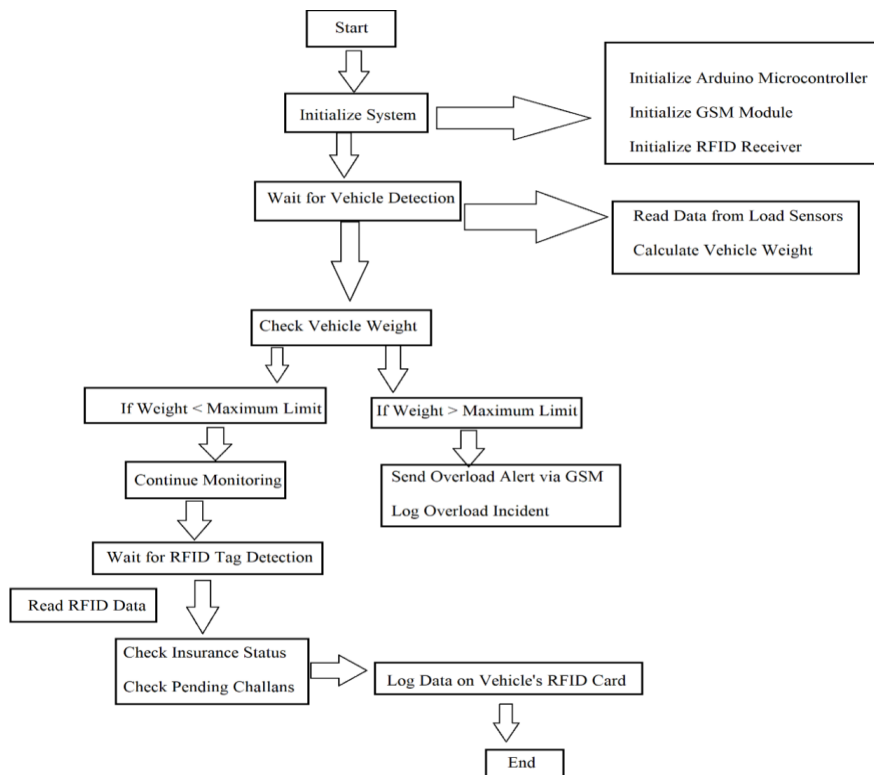

Fig.2 Flow chart

ALGORITHM:

- Step 1: Start.
- Step 2: Initialize the Arduino microcontroller, load sensors, GSM module, and RFID receiver.
- Step 3: Wait for a vehicle to be detected on the road.
- Step 4: Read data from the load sensors.
- Step 5: Calculate the vehicle's weight.
- Step 6: Check if the vehicle weight is within the maximum limit.
- If weight is within the limit:
 - Continue monitoring
 - If weight exceeds the limit:
 - Send an over load alert via GSM.
 - Log the over load incident.
- Step 7: Wait for an RFID tag to be detected on the vehicle.
- Step 8: Read RFID data from the tag.
- Step 9: Check the insurance status for the vehicle.
- Step 10: Check for pending Challans as associated with the vehicle.
- Step 11: Log data on the vehicle's RFID card.
- Step 12: Repeat the monitoring process for additional vehicles (Go to Step 3).
- Step 13: End.

PROBABLE OUTCOME:

- **Reduced Accident Rates:** By detecting and preventing vehicle overloading, the system can potentially reduce accidents caused by excessive vehicle weight.
- **Minimized Road Damage:** Fewer overloaded vehicles can contribute to reduced wear and tear on road infrastructure, saving maintenance costs.
- **Enhanced Traffic Flow:** Overload prevention and efficient traffic management may lead to smoother traffic flow, reducing bottlenecks and congestion.
- **Increased Road Durability:** Fewer overloaded vehicles mean less stress on roads, potentially extending their lifespan and saving on repair costs.
- **Improved Vehicle Lifespan:** Reduced overloading can extend the life of vehicles, reducing maintenance and replacement costs for fleet owners.
- **Promotion of Responsible Road Behaviour:** The system encourages vehicle owners to comply with insurance regulations and clear pending Challan, fostering responsible road behaviour.
- **Safer Roads for All:** Safer roads benefit all road users, from pedestrians to drivers, contributing to a safer and more comfortable road environment.
- **Efficient Traffic Policing:** Traffic authorities can focus their efforts on vehicles that require immediate attention, optimizing resource allocation.
- **Effective Insurance Verification:** The system ensures that insured vehicles are on the road, reducing the number of uninsured vehicles and potential liabilities.
- **Streamlined Data Access:** Centralized data on RFID cards simplifies access to crucial vehicle information for law enforcement and insurance companies.
- **Reduced Traffic Fines Backlog:** The project can help clear pending challenges, improving traffic fine collection rates.
- **Preventive Maintenance:** Early detection of overweight vehicles allows for preventive maintenance, reducing the risk of vehicle breakdowns on the road.
- **Lower Insurance Claims:** Ensuring that insured vehicles are compliant with regulations can lead to lower insurance claim payouts for accidents.
-

III. CONCLUSION

The “Real-time Vehicle Overload Alert, Insurance Verification, and Challan Status Monitoring System” is a technology-driven approach to enhance road safety, traffic management, and compliance. While it offers significant advantages, including real-time alerts and efficiency, it's not without challenges, such as setup costs and maintenance. In practical applications, this system holds promise for safer and more organized roads, particularly on highways, in urban traffic management, logistics, public transportation, and parking facilities. It's a step forward in improving our road networks.

IV. ACKNOWLEDGEMENT

Ability and ambition are not enough for success. Many able people fail to achieve anything worthwhile because he or she has not been properly guided and directed. The project on “Real-Time Vehicle Overload Alert, Insurance Verification, and Challan Status Monitoring System” is an outcome of guidance, moral support, and devotion bestowed on us throughout our work. First and foremost, we offer our sincere phrases of thanks to Dr. Pawar. K.P, Principal and Er. Auti P.D, Project Coordinator and Dr. Patil. V.V, Project Guide for their guidance and constant supervision as well as for providing necessary information during the whole year. We express our gratitude to Dr. Patil. V.V, Head of the E&TC department for their kind cooperation.

Finally, I would like to express my gratitude towards my parents and all teaching and nonteaching staff members of the E&TC department for their kind cooperation and encouragement which helped us in the completion of this project.

REFERENCES

- 1) Arrive Alive, "Overloading and Road Safety," pp.1–5,2016, [Online]. Available: <https://arrivealive.co.za/pages.aspx?u=Overloading-and-Road-Safety>.
- 2) R. Shah, Y. Sharma, B. Mathew, V. Kateshiya, and J. Parmar, "Review Paper on Overloading Effect," *Int. J. Adv. Sci. Res. Manag.*, vol. 1, no. 4, pp. 2–5, 2016, [Online]. Available: www.ijasrm.com.
- 3) T. B. JOEWONO and H. KUBOTA, "Safety and Security Improvement in Public Transportation Based on Public Perception in Developing Countries," *IATSS Res.*, vol. 30, no. 1, pp. 86–100, 2006, doi: 10.1016/s0386-1112(14)60159-x.
- 4) K. Hassan, A. Sam, and D. Machuve, "OVERVIEW ON PASSENGERS OVERLOAD CONTROL IN PUBLIC BUSES CASE STUDY: TANZANIA," vol. 2, no. 8, pp. 2536–2540, 2013.
- 5) S. Xu and Q. Zhao, "Study on the vehicle-mounted overloading control system for passenger vehicles," *Procedia Eng.*, vol. 15, pp. 1214–1218, 2011, doi: 10.1016/j.proeng.2011.08.224.
- 6) S. Hu, M. Kong, and C. She, "Design of vehicle overload detection system based on geophone," *J. Phys. Conf. Ser.*, vol. 887, no. 1, 2017, doi: 10.1088/1742- 6596/887/1/012021.
- 7) M. G. Guillemette, I. Fontaine, and C. Caron, "Hybrid RFID-GPS real-time location system for human resources: Development, impacts and perspectives," *Proc. Annu. Hawaii Int. Conf. Syst. Sci.*, pp. 1–10, 2008, doi: 10.1109/HICSS.2008.195.
- 8) K. R. Prasanna and M. Hemalatha, "RFID GPS and GSM based logistics vehicle load balancing and tracking mechanism," *Procedia Eng.*, vol. 30, no. 2011, pp. 726–729, 2012, doi: 10.1016/j.proeng.2012.01.920.
- 9) C. Matheswaran and V. Senthilkumaran, "Bus Monitoring System Based on RFID Technology with GSM Communication," vol. 4, no. Vi, pp. 165–170, 2016.
- 10) S. Bagui, A. Das, and C. Bapanapalli, "Controlling Vehicle Overloading in BOT Projects," *Procedia - Soc. Behav. Sci.*, vol. 104, pp. 962–971, 2013, doi: 10.1016/j.sbspro.2013.11.191.
- 11) M. R. Karim, N. I. Ibrahim, A. A. Saifizul, and H. Yamanaka, "Effectiveness of vehicle weight enforcement in a developing country using weigh-in-motion sorting system considering vehicle by-pass and enforcement capability," *IATSS Res.*, vol. 37, no. 2, pp. 124–129, 2014, doi: 10.1016/j.iatssr.2013.06.004.
- 12) L. Rafalski, "ANPR-MMR WIM for detection of overloaded vehicles," no. March, 2014.
- 13) Journal, T. Special, and R. Reddy, "Analysis of Overloading Prevention System in Trucks," vol. 6, no. 2, pp. 224–228, 2015.
- 14) Grakovski and I. Kabashkin, "Project" Fiber Optic Sensor Applications for Automatic Measurement of the Weight of Vehicles in Motion: 'PROJECT' FIBER OPTIC SENSOR APPLICATIONS FOR AUTOMATIC MEASUREMENT OF THE WE ... PROJECT 'FIBER OPTIC SENSOR APPLICATIONS FOR AUTOMATIC MEASUREMENT OF THE WEIGHT OF VEHICLES IN MOTION: RESEARCH AND DEVELOPMENT'. FOREWORD," no. January, 2014.
- 15) M. Lydon, D. Robinson, S. E. Taylor, G. Amato, E. J. O. Brien, and N. Uddin, "Improved axle detection for bridge weigh-in-motion systems using fiber optic sensors," *J. Civ. Struct. Heal. Monit.*, vol. 7, no. 3, pp. 325–332, 2017, doi: 10.1007/s13349-017- 0229-4.