



A Research Paper on “IoT Based Accident Prevention & Alerting System using Raspberry Pi”

¹Mr. Hardik Chotalia, ²Mr. Deep Bansode, ³Mr. Shivsai Panchal, ⁴Mr. Sagar D.Dhawale

^{1,2,3}Student, Department of Electronics and Telecommunications, Dr. D. Y. Patil School of Engineering and Technology, Lohegaon, Pune

⁴Assistant Professor, Department of Electronics and Telecommunications, Dr. D. Y. Patil School of Engineering and Technology, Lohegaon, Pune

Abstract: The project describes the development of an IoT-based accident prevention and alerting system for vehicles. The system utilizes Raspberry Pi 3B+ to collect data from various sensors and initiate actions to prevent accidents and notify emergency services when one occurs. The system continuously monitors the driver's state through an alcohol sensor and the vehicle's surroundings using an ultrasonic sensor. The system uses tilt sensor & vibration sensor. If the system detects a value exceeding a predefined threshold, indicating a possible drunk state, the alcohol sensor detects the presence of alcohol, an alarm is triggered to warn the driver. The ultrasonic sensor constantly measures the distance between the vehicle and nearby objects. If a collision is detected by the vibration sensor & tilt sensor detecting possible rollover, exceeding a specific threshold, the system retrieves the location coordinates using the GPS module and transmits them, along with an emergency message, to designated contacts via SMS using the GSM module. This enables an emergency response, potentially minimizing injuries and saving lives.

Index Terms - IoT, Raspberry Pi, GPS, GSM, Sensors, etc.

I. INTRODUCTION

Accidents are a major issue, with drunk driving leading to multiple accidents and poor sleep and drowsiness causing accidents. The Internet of Things (IoT) technology can help in accident prevention and early warning systems. IoT-based systems use sensors to monitor potential hazards, such as vehicle speed, and can alert emergency services or prompt drivers to take action. This project aims to develop an IoT-based system using Raspberry Pi, infrared, tilt, ultrasonic, vibration, alcohol, DC motor, motor driver, GPS module, and GSM module. The system detects potential hazards in real time and triggers alarms to prevent or mitigate accidents. The system is designed for operating machines like engines and alarms, and is versatile and adjustable, allowing for customization to detect and respond to different dangers. As IoT technology evolves, more innovative solutions will emerge in this area. The escalating number of accidents, on roads and in settings has become a public safety issue. These incidents lead to loss of life, property and resources. To address this problem we propose developing an IoT powered Accident Prevention and Alerting System that utilizes hardware components. According to the data provided by the government, the number of people killed in traffic accidents in each state in 2022. One thousand registered vehicles equals one fatality, which is the definition of the fatality rate. Uttar Pradesh has the highest death rate (17.0), while Sikkim has the lowest (4.4).

II. AIM & OBJECTIVES

To assure the avoidance of accidents, The system can keep an eye out for possible threats by using sensors. If it senses any dangers, it can alert the driver right away. Take action to stop mistakes from happening. To minimise the effects of errors, The system has the capability to promptly and effectively notify emergency services in the event of an accident. By acting quickly, you can lessen the impact of accidents and possibly save lives.

III. WORKING PRINCIPLE

The process begins with the flowchart continuously reading four sensors: tilt sensor, vibration sensor, ultrasonic sensor, and alcohol sensor. For preventive measures, the system checks the alcohol and ultrasonic sensors individually. If alcohol is detected, the LED is activated to provide visual aid to the driver, and the motors of the car are stopped with the help of the motordrive. Similarly, if the ultrasonic sensor detects any objects within a predefined threshold, the buzzer gets activated to provide an audible alert to the driver. For alerting purposes, the flowchart then checks each sensor individually. It first detects whether tilt and vibration have occurred above the threshold simultaneously. If the answer is yes, the process jumps to "Accident Detected." If an accident is detected, GPS and GSM are activated to send location coordinates to the rescue team or designated contacts. The process ends after the SMS is sent. If none of the sensors trigger an alarm individually, the process doesn't detect an accident and moves to the end.

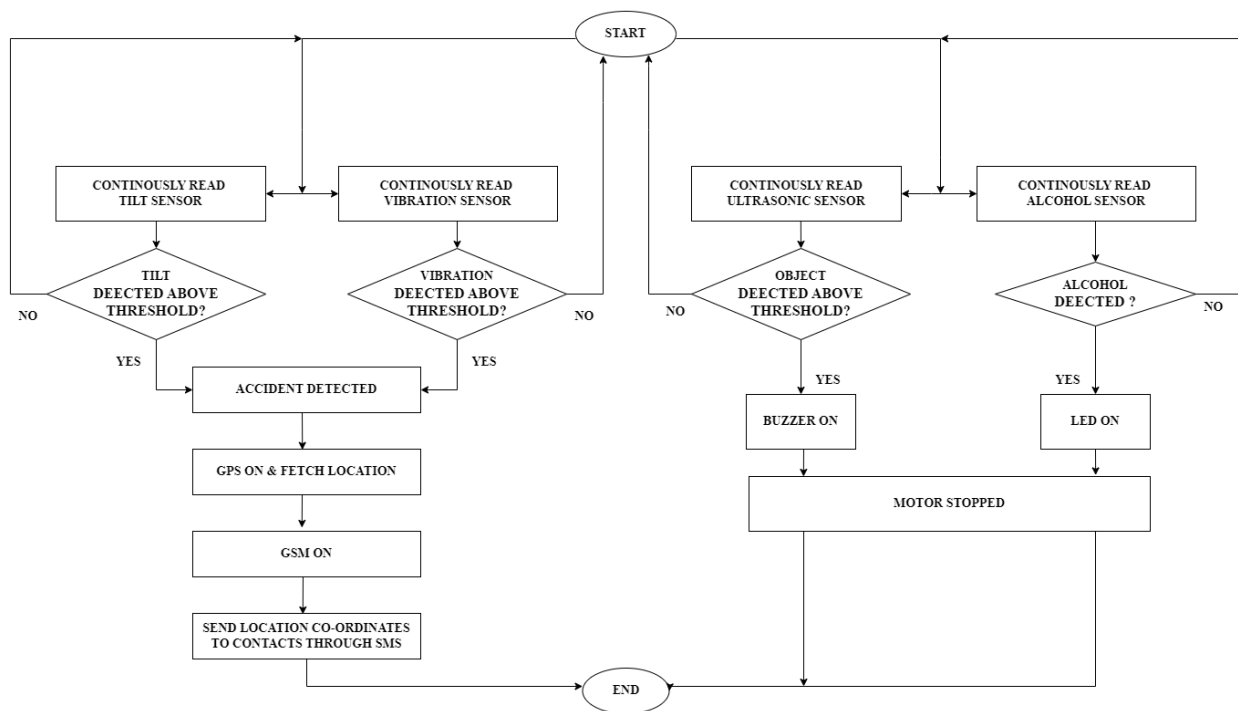

Fig 3.1. Flow Chart of IoT based Accident Prevention & Alerting System Using Raspberry Pi

IV. PROPOSED SYSTEM

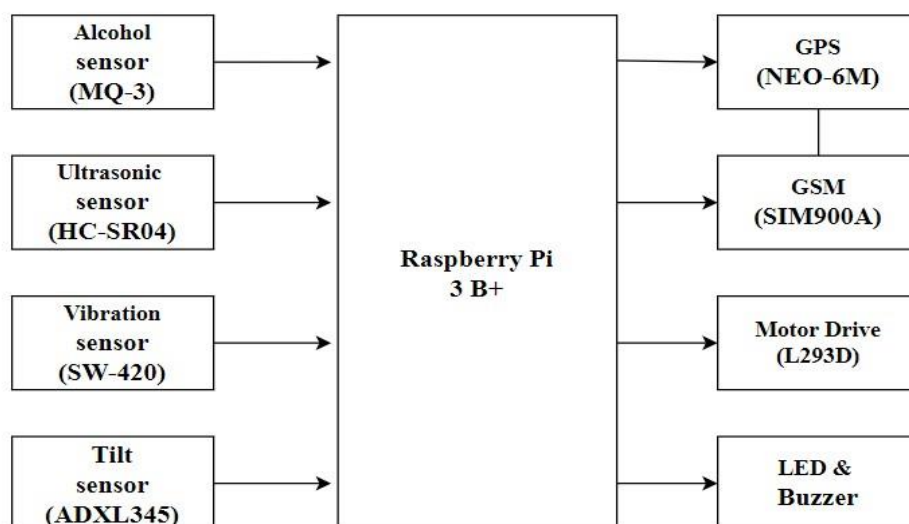

Fig 4.1. Block Diagram of IoT based Accident Prevention & Alerting System Using Raspberry Pi

The Raspberry Pi acts as the brain of the entire system. It is used to take input from the sensors and conduct necessary actions based on the algorithm given to the system. The tilt sensor measures acceleration and is often used in motion tracking and navigation applications. It measures acceleration, gyroscope, and magnetometer data. The alcohol sensor detects the presence of alcohol in the air and is often used in breathalyzers and other breath analysis equipment. A vibration sensor detects the presence of vibrations and is often used in security systems and other applications that need to detect movement or intrusion. Ultrasonic sensors can be used to measure distance. Ultrasonic sensors use sound waves to measure distance. A GPS or Global Positioning System module is a device used to receive signals from GPS satellites and determine its location on Earth. The NEO-6M is a popular GPS module that can be used with Arduino and Raspberry Pi. A GSM is a device that receives and transmits mobile signals to send SMS on any mobile device. The SIM900A is a popular GSM module that can be used with Arduino and Raspberry Pi. An L293D is an integrated circuit used to drive and stop DC motors. LED and Buzzer are used to provide visual and audible preventive measures to driver.

V. METHODOLOGY

Raspberry Pi 3B+ : The Raspberry Pi 3 Model B+ is a credit-card sized computer developed in the UK by the Raspberry Pi Foundation to promote the teaching of basic computer science. It features a 1.4 GHz quad-core processor, 1GB of RAM, and various ports like HDMI and USB. The improved thermals allow the CPU to run at a higher clock speed than previous models. It also boasts faster wireless and ethernet compared to its predecessors making it a versatile option for hobbyists and educators alike.

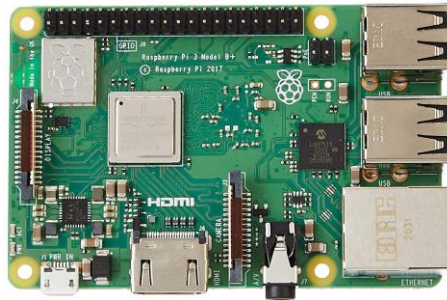

Fig 5.1. Raspberry Pi Model 3B+

Specifications :-

- Processor: Broadcom BCM2711, Quad core Cortex-A72 (ARM v8) 64-bit SoC @ 1.8GHz
- Memory: 1GB, 2GB, 4GB or 8GB LPDDR4-3200 SDRAM
- Connectivity: 2 × micro-HDMI® ports (up to 4kp60 supported), 2 × USB 3.0 ports, 2 × USB 2.0 ports, Gigabit Ethernet, 802.11ac wireless, Bluetooth 5.0, BLE
- Other features: Raspberry Pi standard 40 pin GPIO header

Tilt Sensor (ADXL345) : The ADXL345 is a small, low-power, three-axis accelerometer that excels at measuring tilt. It has a high resolution (13 bits) and can measure static acceleration due to gravity. This makes it ideal for applications like orientation sensing, fall detection, and keeping track of a device's position. The sensor can also be configured to measure in different g-ranges.



Fig 5.2. ADXL345

Specifications :-

- Range: ± 2 g, ± 4 g, ± 8 g, or ± 16 g
- Supply voltage: 1.8 V to 3.6 V
- Operating temperature range: -40 °C to $+85$ °C
- Resolution: 13 bits

Vibration Sensor (SW-420) : The SW-420 is a high-sensitivity vibration sensor that can be used in various applications. It detects vibrations and shocks and outputs a signal based on the level of detection. The sensitivity can be adjusted using a built-in potentiometer. This sensor is commonly used in alarms, like theft alarms or earthquake alarms, and condition monitoring for machines.



Fig 5.3. SW-420

Specifications :-

- Operating Voltage: 3.3V - 5V
- Output Type: Digital (High/Low)
- Sensitivity: Adjustable (Potentiometer included)
- Detection Range: Adjustable (Dependent on sensitivity setting)

Ultrasonic Sensor (HC-SR04) : The HC-SR04 is a well-known ultrasonic sensor that uses sound waves to determine distance. It operates by first emitting a pulse of sound with a high frequency and then checking for the echoes that an object returns. By measuring the time it takes for a sound wave to travel round trip, the sensor can calculate an object's distance from itself. For a variety of robotics and hobbyist projects, the HC-SR04 sensor is an excellent choice due to its low cost and simple operation.



Fig 5.4. HC-SR04

Specifications :-

- Operating voltage: DC 5V
- Operating current: 15mA
- Working frequency: 40KHz
- Ranging distance: 2cm to 400cm

Alcohol Sensor (MQ3) : A popular semiconductor sensor for identifying alcohol gas is the MQ-3. It reacts to alcohol quickly and with strong sensitivity. The more alcohol there is in the air, greater the sensor resistance. For MQ-3 to function at its best, a heating element must be kept at a particular temperature. It's crucial to remember that MQ-3 sensors can react to other gases as well, such as methane and benzene, and are not just limited to alcohol.

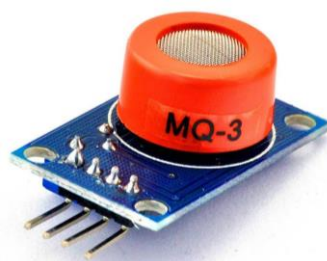

Fig 5.5. MQ3

Specifications :-

- Sensitivity Range: 300 to 10,000 ppm
- Operating Voltage: Typically operates at 5V DC.
- Operating Temperature: -10°C to 50°C.

GPS Module (NEO-6M) : The NEO-6M is a popular GPS module known for its small size, low power consumption, and high accuracy. It uses MediaTek's MT3339 chipset to receive and process satellite signals, making it suitable for hobbyists and drone applications. It can track satellites simultaneously and communicates data using various GPS NMEA protocols.

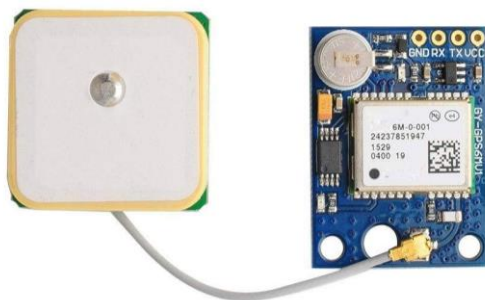

Fig 5.6. GPS NEO-6M

Specifications :-

- Power Supply: 3V-5V
- Baud Rate: 9600
- Module Dimensions: 23mm x 30mm
- Antenna Dimensions: 25mm x 25mm

GSM Module (SIM900A) : The SIM900A is a GSM/GPRS module that provides cellular network connectivity for your projects. It allows you to make and receive calls, send and receive text messages, and even connect to the internet using GPRS. The SIM900A is a popular choice for hobbyists and makers due to its affordability, ease of use, and wide range of capabilities. It is typically controlled using AT commands, which are a set of instructions specifically designed for communicating with cellular devices.



Fig 5.7. GSM SIM900A

Specifications :-

- Power Input: 3.4V to 4.5V and 12V
- Operating Frequency: EGSM900 and DCS1800
- Dual-Band Frequencies: 900/1800 MHz
- Dimensions: 24mm x 24mm x 3mm

Motordrive (L293D) : The L293D is an integrated circuit (IC) that acts as a motor driver. It allows you to control two DC motors with a microcontroller. The L293D can control the direction and speed of the motors, making it a popular choice for robotics and hobbyist projects. It can handle currents up to 600mA and works with voltages between 4.5 and 36 volts.

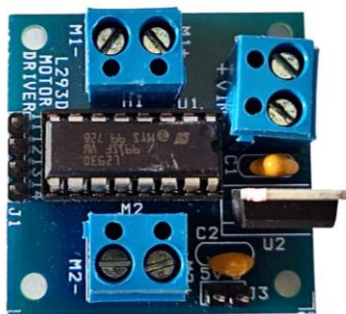

Fig 5.8. L293D

Specifications :-

- Operating voltage: 4.5V to 36V
- Maximum current: 600mA per channel
- Logic voltage: 2V to 7V
- Thermal shutdown: Yes

VI. FUTURE SCOPE

1. **Computer Vision and Machine Learning:** Integrate a camera and leverage machine learning algorithms to analyze real-time video feeds. This could enable features like object detection (cars, pedestrians), lane departure warning, and traffic sign recognition, leading to more comprehensive accident prevention.
2. **Driver Monitoring:** Incorporate a camera to monitor driver drowsiness, distraction, or intoxication through facial recognition and eye tracking, prompting alerts or taking corrective actions.
3. **Cloud Integration:** Connect the system to the cloud for real-time data storage, analysis, and remote monitoring. This allows for centralized management and potential integration with emergency response services.
4. **Post-Crash Assistance:** Develop features like automatic airbag deployment or post-crash communication protocols to improve passenger safety and expedite rescue efforts.

VII. RESULTS

The IoT-based accident prevention and alerting system using Raspberry Pi is able to achieve the following results: When alcohol is detected as driver intoxication, the LED turns ON as a reminder to the driver to prevent accidents. If alcohol is detected in the breath of the driver, the motors i.e. the wheels of the car are stopped to prevent any accident in the drunken state of the driver. If an obstacle is detected above the threshold value of the ultrasonic sensor, the buzzer turns on to alert the driver and prevent an accident. If an obstacle is detected above the threshold value of the ultrasonic sensor, the motors i.e. wheels of the car are stopped to prevent any accident. When the vibration sensor detects any vibration as an impact and the tilt sensor detects any rollover of the car, GPS and GSM are activated to alert and send GPS coordinates with the help of SMS to selected contacts or the rescue team to provide aid to the driver and prevent serious injuries or death.

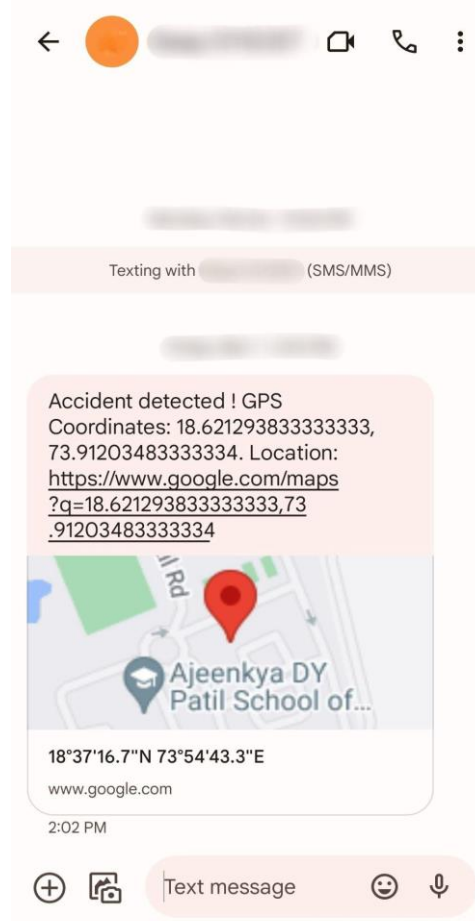

Fig 6.1. Accident detected SMS alert.

VII. CONCLUSION

In the event that an alcohol or object detection sensor reading surpasses a predetermined threshold, signalling a potential loss of vehicle control or approaching collision, reduce the chance of accidents by turning off the DC motor. Send SMS messages using the GSM module to notify emergency services and pre-arranged contacts of the accident site. The messages include the GPS coordinates obtained from the NEO-6M GPS module. If the MQ-3 sensor detects alcohol or if the ultrasonic sensor detects an impediment, provide the driver with an audio-visual alarm via the buzzer and LED. Overall, by raising driver awareness and promptly notifying users of accidents, this system can be a useful tool for enhancing road safety.

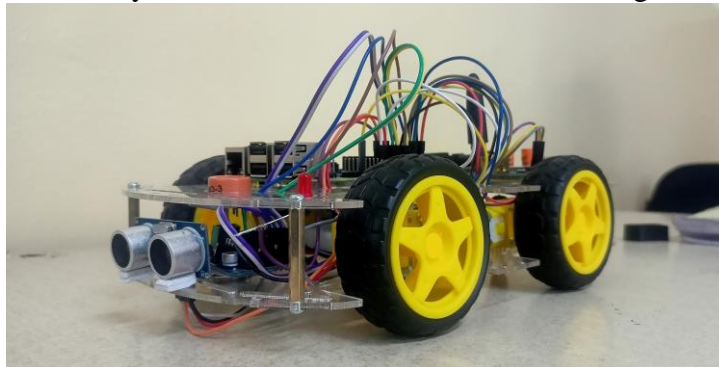

Fig 7.1. Implemented Model

VIII. ACKNOWLEDGEMENT

We would like to thank the head of the department of electronics and telecommunication engineering first and foremost for giving us the chance to work on the recommended system. We genuinely appreciate our guide's wise counsel and perceptive suggestions, without which this suggested task would not have been pursued. We sincerely appreciate our dear guide's support, timely aid, and direction in getting us through this proposed work in the allocated time.

REFERENCES

- [1] Basava and P. Karpagavalli. "IoT BASED VEHICLE TRACKING USING GPS SENSOR AND GSM MODULE ON RASPBERRY PI." , 9 (2020): 4553-4561. <https://doi.org/10.37418/amsj.9.7.24>.
- [2] J. Celaya-Padilla, J. S. Romero-González, C. Galván-Tejada, J. Galván-Tejada, H. Luna-García, J. G. Arceo-Olague, N. Gamboa-Rosales, C. Sifuentes-Gallardo, A. Martínez-Torteya, José Ismael de la Rosa Vargas and Hamurabi Gamboa Rosales. "In-Vehicle Alcohol Detection Using Low-Cost Sensors and Genetic Algorithms to Aid in the Drinking and Driving Detection." *Sensors (Basel, Switzerland)*, 21 (2021). <https://doi.org/10.3390/s21227752>.
- [3] Kalpana Seelam and Ch. Jaya Lakshmi. "An Arduino based embedded system in a passenger car for road safety." *2017 International Conference on Inventive Communication and Computational Technologies (ICICCT) (2017): 268-271*. <https://doi.org/10.1109/ICICCT.2017.7975201>.
- [4] Parveen Kaur, A. Das, M. Borah and Smriti Dey. "Smart Vehicle System using Arduino." *ADBU Journal of Electrical and Electronics Engineering (AJEEE)*, 3 (2019): 20-25.
- [5] Karanam Niranjan Kumar et al. "Automatic Accident Rescue System Using IoT." *International Conference on Computer Networks and Communication Technologies (2018)*. https://doi.org/10.1007/978-981-10-8681-6_52.
- [6] M. Ulum et al. "Comparison Of Voltage Measurements on DC Gearbox Motor and PWM Voltage Based On Arduino Uno." *E3S Web of Conferences (2021)*. <https://doi.org/10.1051/e3sconf/202132802014>.
- [7] Dewan, M., & Agarwal, A. (2020). IOT Based Smart Vehicle Monitoring and Tracking System. *2020 9th International Conference System Modeling and Advancement in Research Trends (SMART)*, 175-178. <https://doi.org/10.1109/SMART50582.2020.9336791>.