



# IOT Based Baby Monitoring Cradle System

<sup>1</sup>Divya Sontakke, <sup>2</sup>Akansha Kand, <sup>3</sup>Sneha Sawant, <sup>4</sup>Prof. Mrs. Meenakshi Annamalai

<sup>1</sup>UG Student, E&TC Engineering, Bhivarabai Sawant Institute of Technology & Research Pune, Maharashtra, India.

<sup>2</sup>UG Student, E&TC Engineering, Bhivarabai Sawant Institute of Technology & Research Pune, Maharashtra, India.

<sup>3</sup>UG Student E&TC Engineering, Bhivarabai Sawant Institute of Technology & Research Pune, Maharashtra, India.

<sup>4</sup>Asst. Professor, E&TC Engineering, Bhivarabai Sawant Institute of Technology & Research Pune, Maharashtra, India.

*Abstract:* The current number of working mothers has greatly increased. Subsequently, baby care has become a daily challenge for many families. Thus, most parents send their babies to their grandparents' house or to baby care houses. However, the parents cannot continuously monitor their babies' conditions either in normal or abnormal situations. Therefore, an Internet of Things-based Baby Monitoring Cradle System is proposed as an efficient and low-cost IoT-based system for monitoring in real time. We also proposed a new algorithm for our system that plays a key role in providing better baby care while parents are away. Our project focuses on the relevant problems faced by parent in monitoring and nurturing their child while working. This project aims at reducing the challenges faced by parent by developing an IOT based baby Monitoring Cradle System that will assist Parent in monitoring their child. This cradle is equipped with a swinging mechanism which swings automatically on detection of baby crying sound. This proposed smart cradle has been integrated with a camera to provide continuous surveillance to parents. An Arduino, sound sensors, wetness sensor, swinging mechanism along with other electronic components are used to upgrade existing cradle to meet the Present-day requirements. This project is quite efficient and reliable which can deliver result better than conventional cradle.

## I. INTRODUCTION

Child care is of most extreme significance for a parent. The present quick paced world makes it hard for parents to continuously look after their kid. After long working hours, it is hard for parents to constantly watch out for their kid. To help such parents, this paper represents the idea of a SMART CRADLE SYSTEM. The smart baby cradle helps working women balance their work and domestic chores.

Besides, there are extra features or functions provided by the newly automatic cradle that are beneficial for parents. In this busy life it will be very difficult to control the babies and if someone is hiring a professional to take care of their infants, the security of the infant is questionable. Moreover, in today's life, it is very hard even for the homemakers to sit near their babies and smooth them whenever they feel uncomfortable. Hence, the use of the Internet of Things helps in dealing with this problem. Smart cradle systems for child monitoring using IoT allows parents to monitor the child through the Mobile application. The main circuits used for this work are Sound sensor, moisture sensor, methane sensor and contactless temperature sensor.

The proposed work implements a Smart Cradle System using cloud services for monitoring the baby inside the cradle and measuring the body temperature, monitoring bed wet and smelly diaper condition, automatic swinging of cradle if sound frequency exceeds threshold value and comforting the baby by monitoring room temperature and turning on the fan. It will also remind parents to feed the baby after every 2 hours or user defined hours. Also, this system will also notify parents about activities of the baby and activate alarm. Parents can also watch their baby live even when they are not at home. Thus, the project bridges the gap between the working parent and their child. The entire system works with the purpose of providing convenience by

continuously monitoring every activity of the infant and thereby providing real time details and updates to the parents.

## II. LITERATURE REVIEW

Marie R. Harper and Maxine R. Blea developed the first automatic rocking cradle which swings side by side on a horizontal axis which replicate the motion same as achieved by human oscillation of cradle. Spring motors are used to provide oscillatory motion to crib. Springs motors are attached to the crib of cradle that produce motion same as human efforts. The spring motor is of any known type in which the gear –operating means is easily stopped when the slightest resistance or opposition to its movement is encountered, thereby providing on extremely safe device for use with small children or babies. The advantages of this system is cost effectiveness, safe for small babies as it has mechanism to stop swinging of crib whenever a resistance is occurred, require less human efforts and presence. The limitation of this system is it does not support video monitoring [1].

Yang HU developed an algorithm to control the speed of motors based on the parameters obtained from baby monitoring this model help the user to control the speed of swinging on pattern of intensity of baby crying. [2].

In [3] authors have designed a cradle system with an android app to monitor baby, which swings automatically after detection of baby crying sound. The principle behind this mechanism is that a sound sensor detect sound made by baby during crying and compare it to Preset value in microcontroller if sound made by baby is greater than preset value a signal is generated by microcontroller who activates the swing mechanism also an SMS sent to parent phone using GSM module. Additionally, a camera is placed at top connected with cloud server so that parent can request video from camera from any place.

In [4] authors have used a Gas sensor (MQ-135), Temperature sensor (LM-35), sound sensor (KY-038) and a cloud server to integrated it with Raspberry pi in order to upgrade the conventional cradle system to meet the needs of parents. The three sensors record the data collected from baby body parameters and all the information taken from sensors is stored in cloud which keep on sending SMS to parent regarding baby parameters at regular interval of time. This system is user friendly as it requires less hardware components and cost effective. The limitation of this system is that it only informs the parent about baby status but don't take any action to make him/her stop crying.

In [5] introduced a framework which observe all necessary indication of the child like heartbeats and the internal heat level utilizing remote innovation and sound sensors which is used for observing the cry pattern of the child. Additionally, the live images of the infant is obtained through camera module through a Wide Area Network (WAN) which can be sent through mail and it can keep surveillance on the baby from distant areas around the world. The camera module is also induced which is responsible for observing the activities of the child and keeping an eye on the infant's development in a limited area. This framework is easy to use and quite cost effective.

Prof. A.D. Anijkar et.al [6] Without human intervention or automatic control via sensors, the author had created an oscillating or swinging cradle. Through the employment of a revolving driving beam, the Slider-crank mechanism converts rotational motion into translational motion. battery, lead-acid Devices that detect moving objects, especially people, are called motion detectors. Decibel [dB] and adjusted decibel [dBA] sound sensors are used. The sound is measured in decibels. This paper's drawback is that it makes more noise, which disturbs the infant. The proposed system can't handle sound well enough.

Dr. Rawicz, Liu, Lu, Sri et.al [7] The prototype of the smart infant cradle is suggested to have a design specification document that details its design. The final smart baby cradle product will still adhere to the design guidelines in this document, but the electrical parts will be replaced with improved, integrated gadgets. All of the designs in this document will consider the customer and safety specifications that were stated in the functional specification. The labels for the requirements in this document match the labels for the requirements in the functional specification. The restriction is Baby's curiosity: In addition to the potential for an electrical shock, the baby could break or fall off the parts, or even try to bite or consume them. Parents' concerns: Parents are significantly more concerned with safety concerns than product features.

Anritha, Anupreethi et.al [8] Anritha Ebenezer offers a design strategy for a baby cradle that includes a cry-analyzing device that can identify newborn cries. Cradle swings based on sound intensity. Six rocks are produced per minute. It has a wet sensor to show when the infant wets; when the baby wets, the resistance

changes, sending a signal. Other sensors include breathing sensors that send signals in cases of apnea and temperature sensors that display the baby's temperature. In the event that the infant does not cease crying within a specific amount of time, a GSM modem connected to an RS232 port will send a message to the parents.

Harper, Mirada, Blea et.al [9] The first automatic rocking cradle was created by Marie R. Harper and Maxine R. Blea. It swings side to side on a horizontal axis to mimic human oscillation of the cradle. To give the cradle oscillatory motion, spring motors are used. To the cradle or cradle are attached spring motors that create motion similarly to human efforts. A very safe gadget for use with young children or newborns is provided with a spring motor this means it is readily halted when the tiniest resistance or opposition to its movement is encountered. The benefits of this technique include affordability and safety for young babies due to a mechanism that prevents the cot from swinging whenever there is resistance. Durga, Itnal, Soujanya, Basha and Saxena et.al [10] They created a system that employs sensors to track the baby's movements and vital indicators, such as breathing and heart rate, and transmits this information to a cloud-based platform. Parents or other carers can access the data using a smartphone application and keep an eye on the baby's health in real-time. Saude and Vardhini et.al [11] Proposes an Internet of Things (IoT) and Raspberry Pi B+-based smart infant cradle solution. The device is intended to keep an eye on the baby's movements, temperature, and humidity levels and notify the parents if any unusual conditions are found. Sensors that are linked to the Raspberry Pi B+ make up the smart baby cradle system. There are four different types of sensors in this system: temperature, humidity, ultrasonic, and vibration. Because the Raspberry Pi B+ is also connected to the internet, the system can notify the parents' smartphones if any unusual conditions are found.

### III. PROBLEM STATEMENT

At present, female participation in the work force in the industrialized nations has greatly increased, thereby affecting infant care in many families. Both parents are required to work due to the high cost of living. However, they still need to look after their babies, thereby increasing workload and stress, especially of the mother. Working parents cannot always care for their babies. They either send their babies to their parents or hire a baby caregiver while they are working. Some parents worry about the safety of their babies in the care of others. Thus, they go home to check on their babies during their free time, such as lunch or tea break.

### IV. OBJECTIVES

To design the development of an intelligent baby care, which has ability to monitor baby movement, bed-wet condition and body temperature. To make a baby cradle is safe and comfortable for baby with using PIR sensor to detect the movement of the baby body as well as bed-wet condition to keep away baby from hygienic environment. To make cradle innovation that is more flexible and less expensive to market. User friendly-simple and complete with instruction. In the current world full of technology and growing data with digitalization. We are able to bridge the gap between working parents and children. We are proposing a system which can be helpful for modern parents who can't make enough time to look after their child.

### 3. Methodology

The system uses an Arduino as the microcontroller to control all of the components. It is using software Arduino IDE as a platform to make the coding. The project idea develops from the very fact that a woman finds it difficult to concentrate on her child owing to her busy schedule of house life. The situation aggravates when she has a job or has some household business, since she can neither compromise with her work nor she can ignore her child's needs. Many devices are available to ease her task and help her to balance between her work and the needs of her child. Our Automated Cradle proposes to be one of them. There is a need to develop a new low-cost indigenous electronic cradle because the existing cradles are imported and costly. This paper presents the design and implementation of a new indigenous low-cost E-Baby. Cradle that swings automatically when baby cries, for this it has a cry analyzing system which detects the baby cry voice and accordingly the cradle swings till the baby stops crying. The speed of the cradle can be controlled as per the user need. The system has a buzzer that indicates two conditions – first when the mattress is wet, which is an important parameter to keep the baby in hygienic condition, second when baby does not stop crying with in a stipulated time, which intimated that baby needs attention. This system helps parents and nurses to take care of babies without physical attention. The methodology is divided into three parts. The first part is on the design structure, followed by hardware description and the finally on the programming design. All these three parts were assembled together and experiments were then performed to build a system.

### 3.1 System Design

#### 3.1.1 Block Diagram

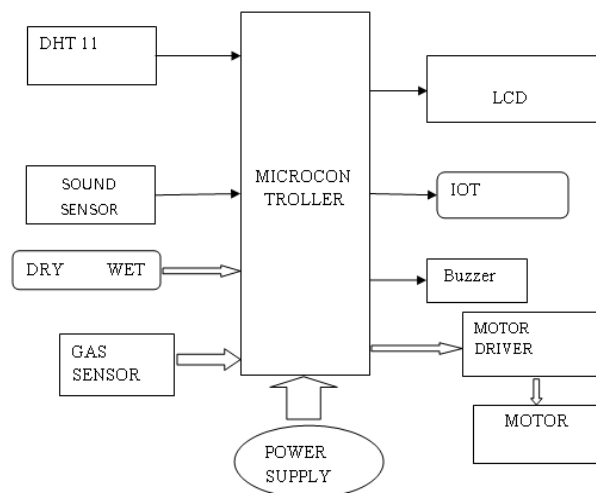

Figure 1. Block Diagram

### 3.2 Working

- The Cradle Swing will be triggered as soon as the Sound sensor crosses the threshold level. The Servo Motor will help in swinging the Cradle.
  1. Start the System.
  2. Check if the baby is making any noise or cry.
  3. If yes, it triggers Servo Motor which leads to swinging of the Cradle.
  4. It also sends the alert message for the same.
  5. You can Turn On/ Off the Cradle Swing by the Android Application.
- This Sensor helps in detecting whether the baby's diaper is wet or dry. If it is detected Wet, it will be intimated to the parent via an Alert Message.
- This will help to keep the baby in a healthy and hygienic Environment.
  1. Start the system.
  2. Keep checking if the baby's Diaper is Wet or Dry.
  3. If yes, notify the same to the parent via message
- This Sensor helps in detecting continuous change in temperature. It sends a message regarding the temperature change to parents.
  1. Start the System.
  2. Keep checking the Temperature of Baby.
  3. If yes, it sends a message to parents through Application.
- This sensor helps in motion detection in this system. It checks whether the baby is inside the cradle or not.
- If there is any unusual activity detected, it sends an alert message to the parent.
  1. Start the System.
  2. Check if there is any movement in the Cradle.
  3. If motion is detected, it sends an alert message to the parent

### 3.3 Advantage and Applications

#### 3.3.1 Advantage

- Cost efficient.
- User friendly.
- Ensures safety.
- Minimum manual work.
- Baby smooth comfortably.
- Baby stays healthy.

#### 3.3.2 Applications

- Cradle system will give parents required time to parent for rest, as if the parents both mother and father goes for the job or even if the mother is house wife.
- Being stress free will definitely create the great atmosphere which will make great atmosphere around the baby. So, it doesn't matter if there is no one to swing cradle it will do swing automatically if the baby is crying.
- It doesn't matter if baby has done pee and no one knows about for long time, but not need to worry cradle system will also give the alert about the wetness in cradle.
- Also, if baby is getting fever or cold Cradle system also have the ability to detect it and send the alert.
- Our cradle will also able to detect if any motion in the cradle by motion sensor for security purpose of the baby.
- Proposed system will help the parents, so that they can take good care of their baby.

## V. RESULTS AND DISCUSSION

### 4.1 Results

This project presents IOT Based Baby Monitoring System for Cradle and it is designed and implemented with ATMEGA 328 Microcontroller in embedded system domain. Experimental work has been carried out carefully. The result shows that higher efficiency is indeed achieved using the embedded system. The proposed system detects each and every activity of baby via different sensors that are attached to the cradle. All data taken from the sensors will be stored in cloud and analyzed at regular intervals and notification about the events and the view images captured are uploaded to cloud server. Cradle will trigger automatically via motor driver by microcontroller when the baby cries continuously upon the set point values. The temperature value, wetness, motion and cry status of the baby displayed on 16x2 LCD display. The System also displays the message on LCD.

The Following figure shows the hardware setup of the proposed system:

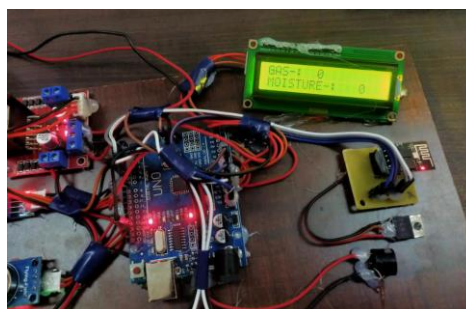
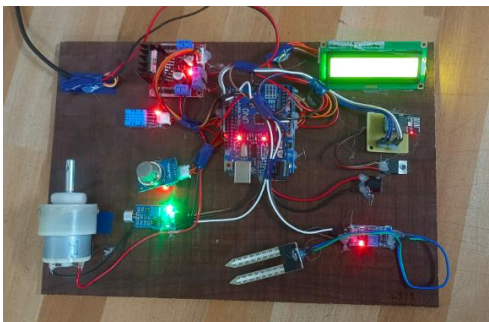

## 4.2 Conclusion

In the model we have implemented various types of sensors which brings the automation to the cradle swing. The study of various types of sensors helps to achieve the smartness of cradle with additional features to the cradle. In the present study, smart baby cradle system is developed. This cradle is capable of detecting the baby cry, mattress wet, temperature, person detection and methane content of the baby and initiate cradle swings automatically when threshold value crossed. The device can be used to minimize the workload of the parents and nurses in home and hospitals respectively. This automatic baby cradle would let the working mother to do household works besides taking care of baby at the same time.

## VI. ACKNOWLEDGMENT

We would wish to thank our Principal Dr. T. K. Nagraj, and Head of Department, Dr. Yogesh Angal for opening the doors of knowledge towards the realization of in this work, we also wish to express true sense of gratitude towards Prof. Meenakshi A. who at every discrete step in study of this work and contributed her valuable guidance and help us to solve every problem that arose. Most likely We would like to express my sincere gratitude towards friends for always being there when we needed them the most. With all respect and gratitude, we would like to thank all authors listed and not listed in references whose concepts are studied and used us whenever required. We owe our all success to them.

## REFERENCES

- [1] Marie R. Harper, La Mirada, Maxine R. Blea: "Automatically rocking baby cradle", US3769641, Date of Patent: Nov. 6, 1973
- [2] Yang Hu, Weihua Gui; "Adaptive sway control for baby bassinet based on Artificial Metabolic Algorithm", School of Information Science and Engineering, Central South University, China.
- [3] M. P. Joshi and D. C. Mehetre, "IoT Based Smart Cradle System with an Android App for Baby Monitoring," 2017 International Conference on Computing, Communication, Control and Automation (ICCUBEA), 2017, pp. 1-4, doi: 10.1109/ICCUBEA.2017.8463676.
- [4] S. Joseph, A. Gautham.J, A. Kumar and M. K. Harish Babu, "IOT Based Baby Monitoring System Smart Cradle," 2021 7th International Conference on Advanced Computing and Communication Systems (ICACCS), 2021, pp. 748-751, doi: 10.1109/ICACCS51430.2021.9442022.
- [5] S. Kavitha, R. R. Neela, M. Sowndarya, Madhu Chandra and K. Harshitha, "Analysis on IoT Based Smart Cradle System with an Android Application for Baby Monitoring," 2019 1st International Conference on Advanced Technologies in Intelligent Control, Environment, Computing & Communication Engineering (ICATIECE), 2019, pp. 136-139, doi: 10.1109/ICATIECE45860.2019.9063773.
- [6] Prof. A.D. Anijkar et.al, "General Idea About Smart Baby Cradle", Int. J. of Innovative Science and Eng., Jan-Feb 2014.
- [7] Dr. Andrew Rawicz, Fanchao Yu Liu, Xiago Lu, Kiru Sri, "Functional Specification for Smart Baby Cradle", Simon Fraser University, 24th Jan 2016.
- [8] Anritha Ebenezer; Anupreethi. S; "Automatic Cradle Movement for Infant Care" Undergraduate Academic Research Journal (UARJ), Vol. 1, No. 1, pp. 2278 –11292012.
- [9] Marie R. Harper, La Mirada, Maxine R. Blea, "Automatically rocking baby cradle", US3769641, Date of Patent: Nov. 6, 1973.
- [10] S. Durga, S. Itnal, K. Soujanya, C. Z. Basha and C. Saxena, "Advanced and effective baby care monitoring Smart cradle system using Internet of Things," 2021 2nd International Conference on Smart Electronics and Communication (ICOSEC),2021,pp.3542,doi:10.1109/ICOSEC51865.2021.9591 955.
- [11] N. Saude and P. A. H. Vardhini, "IoT based Smart Baby Cradle System using Raspberry Pi B+," 2020 International Conference on Smart Innovations in Design, Environment, Management, Planning and Computing (ICSIDEMPC), 2020, pp. 273-278, doi: 10.1109/ICSIDEMPC49020.2020.9299602.